



# Utility Accommodation Policy and Standards

2016



**This Page Intentionally Left Blank**

Table of Contents.....i-i to i-xv

Addendums/Revision Summary Sheet ..... ii-i

Preface..... iii-i

    Federal Highway Administration (FHWA) Approval Letter  
    Order of the Commissioner, Department of Transportation, State of Georgia

**CHAPTER 1: DEFINITIONS AND TERMS**..... Pages 1-1 to 1-19

**CHAPTER 2: AUTHORITY, PURPOSE,  
AND SCOPE OF REGULATIONS**..... Pages 2-1 to 2-21

**2.1 AUTHORITY TO REGULATE**..... 2-1 to 2-2

        2.1.A. Public Road Encroachment Prohibited

        2.1.B. Department Regulation Authorized

        2.1.C. Basis for Policies and Standards

**2.2 AUTHORITY TO REIMBURSE**..... 2-2 to 2-3

        2.2.A. Publicly-Owned Facilities

        2.2.B. Reimbursement for the Public Interest

            2.2.B.1. Utility Facilities Holding a Property Interest

**2.3 PURPOSE OF MANUAL**..... 2-3 to 2-4

        2.3.A. Policies and Standards

        2.3.B. Certification Acceptance

        2.3.C. Revision of Published Policies and Standards

**2.4 SCOPE OF APPLICATION**..... 2-4 to 2-5

        2.4.A. State Highway System

        2.4.B. Local Roads and Streets

            2.4.B.1. Utility Accommodations

            2.4.B.2. Active Projects

            2.4.B.3. Other Projects

**2.5 LIMITATIONS ON RIGHT-OF-WAY OCCUPANCY**..... 2-5 to 2-10

        2.5.A. Protection of Roadway

            2.5.A.1. Existing Utility Pole Obstacles

        2.5.B. Highway with Access Control

            2.5.B.1. Interstate

            2.5.B.2. Limited Access Highways

                2.5.B.2.a. Highways Built on New Location with Limited Access

                2.5.B.2.b. Existing Highways Converted to Limited Access

- 2.5.B.2.c. Crossing of Highways with Access Control
  - 2.5.C. Written Authorization Required
  - 2.5.D. Compliance with Department Policies, Standards, and Specifications
  - 2.5.E. Compliance with Federal Laws and Regulations
  - 2.5.F. Utility Driveways
  - 2.5.G. Private Lines
  - 2.5.H. Service Lines
  - 2.5.I. Abandoned Facilities
    - 2.5.I.1. Hazardous Facilities to be Abandoned
  - 2.5.J. Public Telephone
- 2.6 INSTALLATIONS TO SERVE A HIGHWAY PURPOSE .....2-10**
- 2.7 UTILITY OPERATION AND MAINTENANCE ACTIVITIES .....2-10**
  - 2.7.A. Authorization for Work on Right-of-Way
- 2.8 POLICY ON RELOCATION ..... 2-11 to 2-16**
  - 2.8.A. Authority to Order Removal and Relocation
    - 2.8.A.1. Compensation for Relocation
    - 2.8.A.2. Site for New Installation
  - 2.8.B. Retention of Existing Underground Facilities on Highway Construction and Access Permits
    - 2.8.B.1. Review Factors for Retention Requests
    - 2.8.B.2. Assurances Required for Retention Requests
    - 2.8.B.3. Retention Requirements to Support Highway Loads
  - 2.8.C. Notifications, Failure to Begin or Complete Work
    - 2.8.C.1. Work Found Necessary after Project Letting Date
  - 2.8.D. Failure to Comply
    - 2.8.D.1. Mediation
    - 2.8.D.2. Removal by Department
    - 2.8.D.3. Reimbursement by Utility
- 2.9 POLICY ON TRAFFIC PROTECTION ..... 2-17 to 2-19**
  - 2.9.A. Traffic Control
    - 2.9.A.1. General
    - 2.9.A.2. Flagger
  - 2.9.B. Restriction Against Interference with Traffic
  - 2.9.C. Restrictions on Access
- 2.10 UNDERGROUNDING OF POLE LINES ..... 2-19 to 2-20**
  - 2.10.A. Highway Safety Determination
  - 2.10.B. Aesthetics Determination
  - 2.10.C. Reduced Network Outages Determination

**2.11 WORK TIME RESTRICTIONS OR MORATORIUMS..... 2-20 to 2-21**

**2.12 CONTROL OF SOIL, EROSION, AND SEDIMENTATION.....2-21**

**2.13 ENVIRONMENTALLY SENSITIVE AREAS.....2-21**

**CHAPTER 3: RULES FOR ISSUING  
UTILITY PERMITS.....Pages 3-1 to 3-26**

**3.0 QUALIFICATIONS.....3-1**

**3.1 REQUIREMENTS FOR PERMITS.....3-1 to 3-3**

    3.1.A. Types of Permits

        3.1.A.1. General Encroachment Permit

        3.1.A.2. Blasting Permit

        3.1.A.3. Public Telephone Permit

        3.1.A.4. Vegetation Management Permit

    3.1.B. Terms and Conditions of Permit

**3.2 PERMIT APPLICATION AND APPROVAL PROCEDURE.....3-3 to 3-7**

    3.2.A. Where to Apply

    3.2.B. Authority to Approve

        3.2.B.1. Structures

        3.2.B.2. Blasting

        3.2.B.3. Active Projects

        3.2.B.4. Interstates

        3.2.B.5. Utility Driveways

    3.2.C. Approval of Other Agencies

**3.3 ALLOCATION OF COSTS.....3-8 to 3-9**

    3.3.A. Permit Fee

    3.3.B. Installation Costs

    3.3.C. Reimbursement of Department Expense

    3.3.D. Materials within the Right-of-Way

**3.4 LIABILITY AND CONTROL.....3-9 to 3-13**

    3.4.A. Damages Resulting from Installation

    3.4.B. Injury or Damage to Utilities

    3.4.C. Right-of-Way Restoration and Liability

    3.4.D. Protection of Public

    3.4.E. Inspection of Facilities

    3.4.F. Work by Utility Contractors

- 3.4.G. Final Permit Authority
- 3.4.H. Utility Stop Work Order
  - 3.4.H.1. When to Use a Stop Work Order
  - 3.4.H.2. Return to Work
- 3.5 INSURANCE AND BOND .....3-13 to 3-16**
  - 3.5.A. Requirement for Insurance
  - 3.5.B. Policy Provisions
  - 3.5.C. Insurance Coverages
    - 3.5.C.1. Workers’ Compensation
    - 3.5.C.2. Employers’ Liability Insurance
    - 3.5.C.3. Commercial General Liability Insurance
    - 3.5.C.4. Commercial Umbrella Liability Insurance
  - 3.5.D. Termination of Obligation to Insure
  - 3.5.E. Failure of Insurers
  - 3.5.F. Requirement for Performance Bond, Letter of Credit, or Letter of Escrow
- 3.6 INSTALLATION DETAILS .....3-17 to 3-19**
  - 3.6.A. Plans to Accompany Permit
  - 3.6.B. Construction and Work Requirements
    - 3.6.B.1. Compliance with Plans
    - 3.6.B.2. Work Standards
    - 3.6.B.3. Notice of Work Beginning
    - 3.6.B.4. Notice of Work Completion
- 3.7 TRAFFIC PROTECTION .....3-19 to 3-21**
  - 3.7.A. General
  - 3.7.B. Interstate and Limited Access Highways
  - 3.7.C. All Other Routes
  - 3.7.D. Worksite Traffic Control Supervisor (WTCS)
  - 3.7.E. Notice of Work Beginning
- 3.8 MAINTENANCE .....3-21 to 3-22**
  - 3.8.A. General Restrictions
  - 3.8.B. Maintenance Activities
    - 3.8.B.1. Replacement of any Component Parts
    - 3.8.B.2. Installation of Lateral Service
    - 3.8.B.3. Installation of Additional Appurtenance
    - 3.8.B.4. Routine Inspection
- 3.9 EMERGENCIES .....3-22 to 3-23**
  - 3.9.A. General
  - 3.9.B. Notification

**3.10 ADDITIONAL APPROVAL AND NOTICE OF OTHER AGENCIES.....3-23 to 3-24**

- 3.10.A. Additional Permit or License
- 3.10.B. New Utility Installations on Projects under Construction
- 3.10.C. Notice to Others

**3.11 EFFECTIVE PERIOD OF PERMIT.....3-24 to 3-25**

- 3.11.A. Term of Permit
- 3.11.B. Cancellation for Cause
- 3.11.C. Assignment or Transfer
- 3.11.D. Time Limit on Beginning Work
- 3.11.E. Changes Subsequent to Permit Approval
- 3.11.F. Large Projects

**3.12 IDENTIFICATIONS .....3-25**

- 3.12.A. Worksite Identification
- 3.12.B. Vehicle and Equipment Identification

**3.13 COORDINATION OF REQUIREMENTS.....3-25 to 3-26**

**CHAPTER 4: UTILITY ACCOMMODATION, RELOCATIONS, AND ADJUSTMENTS ON PROJECTS.....Pages 4-1 to 4-55**

**4.0 GENERAL PROVISIONS .....4-1 to 4-8**

- 4.0.A. Roles and Responsibilities
  - 4.0.A.1. State Utilities Office
  - 4.0.A.2. District Utilities Office
  - 4.0.A.3. Utility
- 4.0.B. Project Related Dispute Resolution
  - 4.0.B.1. General Description
- 4.0.C. Overhead/Subsurface Utility Engineering (SUE) Investigations
  - 4.0.C.1. General Description
  - 4.0.C.2. Implementation of SUE

**4.1 UTILITY PROJECT DEVELOPMENT PROCESS.....4-8 to 4-24**

- 4.1.A. Planning/Concept Phase
  - 4.1.A.1. Quarterly District Utilities Coordination Meetings
  - 4.1.A.2. Project Concept Development

- 4.1.B. Public Information Meetings and Reviews
- 4.1.C. Project Design Phase
  - 4.1.C.1. Utility Plan Development
  - 4.1.C.2. Determination of Method of Performance
  - 4.1.C.3. Policy on Including Utilities in Project Contracts
  - 4.1.C.4. Work Plan Approval
  - 4.1.C.5. Determination of Utility Right-of-Way and Easement
  - 4.1.C.6. Method of Acquisition
  - 4.1.C.7. Interest to be Acquired

**4.2 REIMBURSEMENT FOR UTILITY**

**RELOCATIONS AND ADJUSTMENTS..... 4-24 to 4-40**

- 4.2.A. Conditions Governing Reimbursement
  - 4.2.A.1. Participation in Utility Costs by Political Subdivisions
  - 4.2.A.2. Reimbursement Classifications
  - 4.2.A.3. Non-Reimbursement Cases for Facilities in Conflict
- 4.2.B. Determination of Eligibility for Reimbursement
  - 4.2.B.1. Certificate of Eligibility and Supporting Data
  - 4.2.B.2. Partial Eligibility
  - 4.2.B.3. Crossings
  - 4.2.B.4. Longitudinal
  - 4.2.B.5. Other Methods
- 4.2.C. Eligible Costs to be Reimbursed
- 4.2.D. Reimbursement of Consultant and Contractor Services
  - 4.2.D.1. Consultant Services
    - 4.2.D.1.a. Selection of Consultant
    - 4.2.D.1.b. Proposal Requirements
    - 4.2.D.1.c. Department Approval
    - 4.2.D.1.d. Certification of Consultant
  - 4.2.D.2. Contractor Services for Utility Construction
    - 4.2.D.2.a. Solicitation or Advertisement of Bids
    - 4.2.D.2.b. Continuing Contracts
- 4.2.E. Preparation of Cost Estimates
  - 4.2.E.1. Estimate Requirements
    - 4.2.E.1.a. Itemized Detail, Actual Cost, or Lump Sum
    - 4.2.E.1.b. Additional Requirements for Lump Sum Estimates
    - 4.2.E.1.c. Work by Consultants
    - 4.2.E.1.d. Work by Contract
    - 4.2.E.1.e. Certificate of Eligible
  - 4.2.E.2. Estimate Submittal Deadlines
  - 4.2.E.3. Review by Department
- 4.2.F. Agreements
  - 4.2.F.1. Requirements of Agreements
  - 4.2.F.2. Preparation of Agreements



- 4.2.F.3. Departmental Reviews and Approval
- 4.2.F.4. FHWA Approval
- 4.2.F.5. Agreement Change Orders, Modifications, Allotment Requests
  - 4.2.F.5.a. Utility Responsibility
  - 4.2.F.5.b. Department Responsibility
- 4.3 AUTHORIZATION & CERTIFICATION PHASE..... 4-40 to 4-41**
  - 4.3.A. Authorization to Incur Costs
    - 4.3.A.1. Requirement for Written Authorization
    - 4.3.A.2. FHWA Approval
- 4.4 CONSTRUCTION PHASE..... 4-41 to 4-48**
  - 4.4.A. Construction Notification and Coordination
    - 4.4.A.1. Notice of Project Contract Advertisement
    - 4.4.A.2. Notice of Project Contract Award
    - 4.4.A.3. Preconstruction Conference
    - 4.4.A.4. Notice to Department by Utility
    - 4.4.A.5. Traffic Control
  - 4.4.B. Revised Work Plan Approval
  - 4.4.C. Procedures for Utility Damages or Delay Costs
- 4.5 BILLING & PAYMENT PHASE ..... 4-48 to 4-50**
  - 4.5.A. Basis of Reimbursement
    - 4.5.A.1. Reimbursement to Represent Actual Cost
    - 4.5.A.2. Basis of Payment
  - 4.5.B. Progress Bills
    - 4.5.B.1. Frequency
    - 4.5.B.2. Method of Billing
    - 4.5.B.3. Payment
  - 4.5.C. Final Bills
  - 4.5.D. Certification of Final Costs
  - 4.5.E. Audit by Department
  - 4.5.F. Documentation of Costs
    - 4.5.F.1. Detailed Records Required
    - 4.5.F.2. Retention of Records
- 4.6 LOCAL GOVERNMENT PROJECTS..... 4-50 to 4-51**
  - 4.6.A. Lighting Projects
- 4.7 JOINT USE OF UTILITY FACILITIES..... 4-51 to 4-54**
  - 4.7.A. Attachment to Joint-Use Poles
  - 4.7.B. Preconstruction Procedures
    - 4.7. B.1. Overhead/Subsurface Utility Engineering (SUE) Projects

- 4.7. B.2. Non-SUE Projects/New Installations
- 4.7.C. Construction Requirements
  - 4.7.C.1. Work by Local Government
- 4.7.D. Maintenance
- 4.7.E. Reimbursement Criteria

**4.8 INSTALLATIONS TO SERVE A HIGHWAY PURPOSE ..... 4-54 to 4-55**

**CHAPTER 5: UTILITY ACCOMMODATION**  
**CONTROLS AND STANDARDS..... Pages 5-1 to 5-82**

**5.1 GENERAL CONSIDERATIONS..... 5-1 to 5-9**

- 5.1.A. Location of Facilities Within the Right-of-Way
  - 5.1.A.1. Longitudinal Installations
  - 5.1.A.2. Crossings
    - 5.1.A.2.a. Aerial Facilities Right-of-Way Crossings
    - 5.1.A.2.b. Aerial Facilities Roadway Crossings
    - 5.1.A.2.c. Underground Facilities Right-of-Way Crossings
    - 5.1.A.2.d. Underground Facilities Roadway Crossings
  - 5.1.A.3. Use of Drainage Culverts
  - 5.1.A.4. Clearances
  - 5.1.A.5. Preservation of Safety, Visual Quality, and Maintenance Efficiency
- 5.1.B. Utility Facilities Installed Inside and Parallel to the Right-of-Way
- 5.1.C. Utility Facilities Installed Outside and Parallel to the Right-of-Way
- 5.1.D. Design of Utility Facilities
  - 5.1.D.1. Responsibility for Design
  - 5.1.D.2. Governing Codes
  - 5.1.D.3. Design Criteria for Pipelines
  - 5.1.D.4. Appearance Requirements
  - 5.1.D.5. Materials Requirements
  - 5.1.D.6. Provisions for Expansion
- 5.1.E. Preservation, Restoration, and Cleanup
  - 5.1.E.1. Disturbed Areas
  - 5.1.E.2. Drainage
- 5.1.F. Safety and Convenience of Traffic
  - 5.1.F.1. Traffic Control
  - 5.1.F.2. Closing of Trenches or Pits
  - 5.1.F.3. Storage of Materials
  - 5.1.F.4. Residential and Commercial Driveways
- 5.1.G. Scenic Enhancement: Areas for Special Protection
  - 5.1.G.1. Underground Installations
  - 5.1.G.2. Overhead (Aerial) Installations

**5.2 UNDERGROUND UTILITY FACILITIES..... 5-9 to 5-34**

- 5.2.A. Location and Alignment
  - 5.2.A.1. Considerations
  - 5.2.A.2. Controls for Locating Underground Utility Facilities
- 5.2.B. Cover (Depth)
  - 5.2.B.1. Considerations
  - 5.2.B.2. Controls for Cover
- 5.2.C. Encasement
  - 5.2.C.1. Considerations
  - 5.2.C.2. Controls for Encasement
  - 5.2.C.3. Controls for Uncased Carriers
- 5.2.D. Controls for Hazardous Transmittants
  - 5.2.D.1. Cathodic Protection
  - 5.2.D.2. Encasement
  - 5.2.D.3. Markers
- 5.2.E. Controls for Appurtenances
  - 5.2.E.1. Vents
  - 5.2.E.2. Drains
  - 5.2.E.3. Markers
  - 5.2.E.4. Manholes, Vaults, and Hand Holes
  - 5.2.E.5. Fire Hydrants
  - 5.2.E.6. Shut-off Valves
  - 5.2.E.7. Gas Regulator Stations
  - 5.2.E.8. Power and Communication Facilities
  - 5.2.E.9. Pipeline Facilities
- 5.2.F. Installation Methods and Controls
  - 5.2.F.1. Open Cut Construction
    - 5.2.F.1.a. Controls for Trenched Construction
    - 5.2.F.1.b. Controls for Plowing
  - 5.2.F.2. Pavement Cuts
    - 5.2.F.2.a. General Controls
    - 5.2.F.2.b. Surface Restoration
    - 5.2.F.2.c. Test Holes
  - 5.2.F.3. Trenchless Construction
    - 5.2.F.3.a. Techniques
    - 5.2.F.3.b. Controls for Trenchless Construction

**5.3 EXISTING FACILITIES RETAINED UNDER PAVEMENT..... 5-35**

- 5.3.A. General Considerations
- 5.3.B. Controls

**5.4 MANHOLES..... 5-36 to 5-46**

- 5.4.A. Widening Projects (Manholes Currently Outside Existing Pavement)

- 5.4.B. Widening Projects (Manholes Currently in Existing Pavement Area)
- 5.4.C. Resurfacing Only Projects
- 5.4.D. Milling and Resurfacing Projects
  - 5.4.D.1. Case I: Existing Concrete Manhole (Milling & Replacing Same Grade)
  - 5.4.D.2. Case II: Existing Concrete Manhole (Milling & Replacing Different Depth Finish Grade)
  - 5.4.D.3. Case III: Existing Asphalt Manhole
- 5.4.E. Reconstructing Manholes “Approved Manhole Method”
  - 5.4.E.1. Lowering the Manhole
  - 5.4.E.2. Raising the Manhole
  - 5.4.E.3. Lowering and Raising Ring Risers
- 5.4.F. Abandoned Manholes

**5.5 UTILITY TUNNELS AND UTILITY BRIDGES .....5-46**

- 5.5.A. General Considerations
- 5.5.B. Controls
  - 5.5.B.1. Tunneling Specifications
  - 5.5.B.2. Isolation of Hazardous Materials

**5.6 OVERHEAD POWER AND COMMUNICATION LINES .....5-47 to 5-62**

- 5.6.A. General Considerations
- 5.6.B. Controls for Overhead Facilities
  - 5.6.B.1. Types of Construction
  - 5.6.B.2. Horizontal, Vertical, and Radial Clearances
  - 5.6.B.3. Longitudinal Installations
  - 5.6.B.4. Highway Crossings
  - 5.6.B.5. Identification
- 5.6.C. Communication Cables Crossings
- 5.6.D. Power Transmission Lines

**5.7 INSTALLATION ON OR NEAR HIGHWAY STRUCTURES .....5-62 to 5-67**

- 5.7.A. General Considerations
- 5.7.B. Controls for Bridge Attachments
  - 5.7.B.1. Structural and Design Requirements
  - 5.7.B.2. Clearances
  - 5.7.B.3. Aesthetics
  - 5.7.B.4. Restoration
  - 5.7.B.5. Encasement
  - 5.7.B.6. Cathodic Protection
  - 5.7.B.7. Shut-off Valves
- 5.7.C. Controls for Utilities Near Highway Structures

**5.8 SPECIAL CASE UTILITIES (IRRIGATION, DRAINAGE FACILITIES, AND CLAY PIPELINES) ..... 5-67 to 5-70**

- 5.8.A. Controls for Public Right-of-Way by Private Irrigation Lines
  - 5.8.A.1. Highway Crossings
  - 5.8.A.2. Longitudinal Installations
  - 5.8.A.3. Controls
- 5.8.B. Controls for Clay Pipelines
  - 5.8.B.1. Highway Crossings
  - 5.8.B.2. Longitudinal Installations
  - 5.8.B.3. Controls

**5.9 PUBLIC TELEPHONES..... 5-70 to 5-72**

- 5.9.A. General Requirements and Controls
- 5.9.B. Interstate and Limited Access Highways
- 5.9.C. Highways in Rural Areas
- 5.9.D. Urban Streets
- 5.9.E. Signs

**5.10 LIGHTING PROCEDURES-LIGHTING BY PERMIT..... 5-72 to 5-76**

- 5.10.A. General Requirements and Controls
- 5.10.B. Information to Accompany Permit
- 5.10.C. Light Pole/Light Standard Locations
  - 5.10.C.1. Non-Breakaway Light Pole/Light Standards
  - 5.10.C.2. Breakaway Light Pole/Light Standards
- 5.10.D. Wire Requirements
- 5.10.E. Removal of Lighting Facilities

**5.11 WIRELESS FACILITIES..... 5-76 to 5-79**

- 5.11.A. Guidelines
- 5.11.B. Controls for Wireless Facility Installation
  - 5.11.B.1. Collocation on Non- Department Infrastructure
  - 5.11.B.2. Collocation on Department Infrastructure
  - 5.11.B.3. Wireless Support Structures
- 5.11.C. Permits

**CHAPTER 6: VEGETATION MANAGEMENT..... Pages 6-1 to 6-8**

**6.0 GENERAL CONSIDERATIONS..... 6-1**

**6.1 ANNUAL SCHEDULE FOR VEGETATION MANAGEMENT ..... 6-1 to 6-2**

- 6.1.A. Submittal Requirements and Procedures
- 6.1.B. Alternative Compliance
- 6.1.C. Emergency

**6.2 NEW UTILITY FACILITY ENCROACHMENT PERMITS ON INTERSTATE/ LIMITED ACCESS ..... 6-2 to 6-4**

- 6.2.A. Mitigation Plan for Utility Crossings
- 6.2.B. Mitigation Plan for Parallel Utility
- 6.2.C. General Mitigation Plan Requirements
  - 6.2.C.1. Required Plants
  - 6.2.C.2. Schedule
  - 6.2.C.3. Replacement
  - 6.2.C.4. Quality
  - 6.2.C.5. Seasonal Limitations

**6.3 NEW UTILITY FACILITY ENCROACHMENT PERMITS ON NON-INTERSTATE/NON-LIMITED ACCESS ROUTES ..... 6-5**

**6.4 MAINTENANCE REQUIREMENTS FOR EXISTING FACILITIES ..... 6-5 to 6-8**

- 6.4.A. Notification
- 6.4.B. Seasonal Limitations
- 6.4.C. Pesticides
- 6.4.D. Pruning and Removal
- 6.4.E. Mechanical Mowing
- 6.4.F. Erosion Control
- 6.4.G. Debris Removal
- 6.4.H. Unsatisfactory Work

**CHAPTER 7: ACCOMMODATION OF UTILITIES**

**ON DEPARTMENT OWNED**

**RAILROAD RIGHT-OF-WAY.....**

**Pages 7-1 to 7-9**

**7.0 GENERAL ..... 7-1**

**7.1 TYPES OF PERMITS REQUIRED ..... 7-1**

- 7.1.A. General Encroachment Permit
- 7.1.B. Blasting Permit

**7.2 ACCESS CONTROL ..... 7-1**

**7.3 AERIAL FACILITIES .....7-2**

**7.4 UNDERGROUND FACILITIES .....7-2**

**7.5 PARALLEL (I.E. LONGITUDINAL) INSTALLATIONS .....7-2**

**7.6 TRAFFIC CONTROL .....7-2**

**7.7 FLAGGING ..... 7-3 to 7-4**

    7.7.A. Flagging Services

    7.7.B. Cost of Flagging

    7.7.C. Restrictions against Interference of Railroad Operations

**7.8 SAFETY .....7-4**

    7.8.A. Safety Guidelines

    7.8.B. Federal Railroad Administration (FRA) Worker Safety

**7.9 INSURANCE AND BONDING ..... 7-4 to 7-7**

    7.9.A. Requirement for Insurance

**7.10 PLANS TO ACCOMPANY PERMIT APPLICATION .....7-7**

**7.11 APPROVAL PROCESS ..... 7-7 to 7-8**

    7.11.A. District Utilities Office Review

    7.11.B. State Utilities Office Review

**7.12 NOTICES .....7-8**

    7.12.A. Notice of Work Beginning

    7.12.B. Notice of Work Completion

    7.12.C. Notice of Maintenance Work

**7.13 EXCEPTIONS .....7-9**

**7.14 FAILURE TO COMPLY .....7-9**

**7.15 POLICY ON RELOCATION .....7-9**

    7.15.A. Authority to Order Removal and Relocation

**CHAPTER 8: UTILITY POLE SAFETY PROGRAM ..... Pages 8-1 to 8-7**

**8.0 GENERAL .....8-1**

**8.1 FUNDAMENTALS..... 8-2 to 8-3**  
     8.1.A. Objective  
     8.1.B. Goals

**8.2 REQUIREMENTS..... 8-3 to 8-5**  
     8.2.A. Crash Data  
     8.2.B. Relocation  
     8.2.C. Existing Facilities  
         8.2.C.1. Major Rehabilitation or Reconstruction (Category 1)  
         8.2.C.2. Major Rehabilitation or Reconstruction (Category 2)  
     8.2.D. New Facilities

**8.3 MITIGATION POSSIBILITIES..... 8-5 to 8-7**

**8.4 EXCEPTIONS FOR EXISTING & NEW FACILITIES ..... 8-7**

**8.5 PARTICIPATION..... 8-7**

**CHAPTER 9: BROADBAND DEPLOYMENT..... Pages 9-1 to 9-2**

**9.0 GENERAL ..... 9-1**

**9.1 BROADBAND INFRASTRUCTURE DEPLOYMENT..... 9-1 to 9-2**  
     9.1.A. Broadband Utility Coordinator  
     9.1.B. Registration of Broadband Infrastructure Entity  
     9.1.C. Notification of Projects in the STIP  
     9.1.D. Coordination and Collocation Efforts

**CHAPTER 10: DESIGN-BUILD (DB) AND PUBLIC PRIVATE PARTNERSHIP (P3) PROJECTS..... Pages 10-1 to 10-13**

**10.0 GENERAL PROVISIONS ..... 10-1 to 10-3**  
     10.0.A. Scope & Purpose  
     10.0.B. Background and Context: Public Interest Determination and Utility MOUs  
     10.0.C. Reliance

**10.1 RESPONSIBILITIES OF UTILITY OWNERS AS RELATES TO DB/P3 PROJECTS..... 10-2 to 10-9**  
     10.1.A. Obligations in Connection with Project Development (Prior to Award of



DB/P3 Contract)

- 10.1.B.** Utility Owner Self-Performance
- 10.1.C.** Obligations in Connection with the DB/P3 Contract
  - 10.1.C.1.** Required Meetings
  - 10.1.C.2.** Real Property Matters
  - 10.1.C.3.** Emergency Utility Response Information (EURI)
  - 10.1.C.4.** No Conflict Letter Requirements
  - 10.1.C.5.** Verification of Utility Plans and SUE Investigations
  - 10.1.C.6.** Utility Retention Request
  - 10.1.C.7.** Utility Work Plans
  - 10.1.C.8.** Utility Relocation Acceptance Form
  - 10.1.C.9.** General Obligations
- 10.1.D.** Obligations in Connection with Utility Adjustment Plans
  - 10.1.D.1.** Utility Adjustment Plans Prepared by Contractors
  - 10.1.D.2.** Utility Adjustment Plans Prepared by Utility Owners
    - 10.1.D.2.a.** Utility Adjustment Schedule
    - 10.1.D.2.b.** Utility Adjustment Plans
- 10.1.E.** Utility Adjustment Work by Utility Owners
  - 10.1.E.1.** Design and Construction Requirements
  - 10.1.E.2.** Utility Adjustment Field Modification Procedures
  - 10.1.E.3.** Inspection of Utility Adjustment Work
  - 10.1.E.4.** Utility As-Built Plan Requirements

**10.2 BETTERMENTS ..... 10-9**

**10.3 PROJECT RELATED DISPUTE RESOLUTION..... 10-9 to 10-13**

- 10.3.A.** Determining Process for Escalation
- 10.3.B.** Escalation Procedure for Utility Adjustment Work carried out by Contractor in DB/P3 Contract
  - 10.3.B.1.** Escalation Process Step 1
  - 10.3.B.2.** Escalation Process Step 2
- 10.3.C.** Escalation Procedure for Utility Adjustment Work for DB/P3 Project carried out by Utility Owner under Standard Utility Agreement or at Owners Expense

**This Page Intentionally Left Blank**

## ADDENDUM / REVISION SUMMARY SHEET

Date	Page No.	Addendums / Revisions
		<b>Addendum #1</b>
2018-12-01		Updated GDOT Logo & color scheme; added revision date to footer
2018-12-01	i-xi	Revised page numbers, Sections and Section titles to 5.11, adjusted format for all sections following 5.11
2018-12-01	1-3	Added definitions for “Antenna”
2018-12-01	1-5	Added definitions for “Collocate or Collocation”
2018-12-01	1-11	Added definition for “Micro Wireless Facility”
2018-12-01	1-15	Added definition for “Small Wireless Facility”
2018-12-01	1-18	Added definitions for “Wireless Facility” and “Wireless Support Structure”
2018-12-01	5-77 to 5-82	Revised Chapter 5.11 and adjusted page numbers accordingly
		<b>Addendum #2</b>
2020-11-12	5-72 to End of Chapter 5	Revised Chapter 5.10 and adjusted page numbers, accordingly; added revision date to footer
		<b>Addendum #3</b>
2023-05-17	i-i – i-xiv	Revised the Table of Contents to add Chapters 9 and 10; adjusted all page numbers throughout the Manual; added revision date to footer
2023-05-17	ii-i	Corrected date on first entry on this page (ii-i) and added notations for Addendums #2 & #3
2023-05-17	1-1 – 1-3	Added abbreviations for BUC, DB, DBF, DBFM, DBFOM, DUO, P3; UAP, corrected “Utilities” to “Utility” in UAS
2023-05-17	1-3, 1-5 – 1-8; 1-14	Changed “cross roads” to “crossroads” in “Access Control – a.”, added definition for “Broadband Infrastructure”, “Broadband Infrastructure Entity”, “Broadband Services”, “Contract Documents”, revised definition for “Contractor”; added definitions for “DBF Documents”, “DBFM Documents”, “DBFOM Documents”, “Design-Build Agreement”, “Design-Build Documents”, “Design-Build Project”, Design-Builder”, “Developer”, “P3 Project”, “P3 Project Agreement”
2023-05-17	9-1 – 9-2	Added CHAPTER 9: BROADBAND DEPLOYMENT
2023-05-17	10-1 – 10-13	Added CHAPTER 10: DESIGN-BUILD (DB) AND PUBLIC PRIVATE PARTNERSHIP (P3) PROJECTS

**This Page Intentionally Left Blank**

## Preface

The Georgia Department of Transportation is charged with constructing, maintaining and operating the State's highways and bridges safely and efficiently for the benefit of the motorists who use them. The use of right-of-way by water, sewer, gas, power, communications and other utilities is a privilege afforded Utilities by the Department in the general public interest.

The Department recognizes the benefits gained by the Utilities from joint use of right-of-way, where practical, and supports this practice as being in the public interest when adequate controls are employed. In setting forth policies, rules, and regulations for accommodation of utilities, the Department must attempt to minimize the impact that these facilities will have on highway safety, improvements, maintenance, and operations.

Because of the high costs of acquiring new right-of-way, due, in part, to increasing land values and environmental impacts, more and more reliance is being placed on obtaining maximum capacity and usage from existing highway corridors. This requires that emphasis be placed on locating aboveground facilities as far as possible from the traveled way and locating underground facilities where they will not conflict with highway improvements. Utilities locating and operating facilities on right-of-way must accept responsibility to protect the public investment in right-of-way, roadbed, and structures; to maintain adequate traffic service and safety for the highway user during installation, maintenance, and operation of their facilities; and to increase cooperation, coordination, and communication in an effort to expedite project delivery and avoid project delays in both the preliminary engineering (i.e. preconstruction) and construction phases.

This *Utility Accommodation Policy and Standards Manual* outlines the conditions and procedures under which utilities will be permitted to occupy right-of-way in Georgia. While policies and procedures, standards, and rules and regulations are usually initiated and implemented from central or headquarter offices, it is the operations and construction personnel in the field who must make them work. The development of close working relationships between Department and Utility personnel is to be encouraged.

It is not the intent of the Department to cause an unnecessary hardship on any Utility requesting space on right-of-way. We believe the public interest will best be served by maximum communication between the Department, Local Governments, and the Utilities regarding the policies and procedures described herein, the guidance under which they are implemented, and plans for new development and construction of both highway and utility facilities.



U.S. Department  
of Transportation  
**Federal Highway  
Administration**

**Georgia Division**

April 19, 2016

61 Forsyth Street S.W.  
Suite 17T100  
Atlanta, Georgia 30303  
Phone 404-562-3630  
Fax 404-562-3703  
Georgia.fhwa@fhwa.dot.gov

In Reply Refer To:  
HDA-GA

Russell McMurry, P.E., Commissioner  
Georgia Department of Transportation  
One Georgia Center  
600 West Peachtree Street NW  
Atlanta, GA 30308

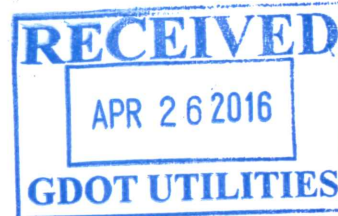

Dear Commissioner McMurry,

The Federal Highway Administration Georgia Division Office has reviewed the Georgia Department of Transportation (GDOT) Utility Accommodation Policy and Standards Manual, 2016 edition and approval has been granted to adopt the updates as submitted.

If you have any questions, please contact Neosha Lawhorn at [neosha.lawhorn@dot.gov](mailto:neosha.lawhorn@dot.gov) or 404-562-3634.

Sincerely,

For: Rodney N. Barry, P. E.  
Division Administrator

Cc: Lee Upkins, State Utilities Engineer

**ORDER OF THE COMMISSIONER  
DEPARTMENT OF TRANSPORTATION  
STATE OF GEORGIA**

WHEREAS, the Department of Transportation has in the past adopted Regulations for Utility Accommodation Policies and Standards on Public Highways, Roads and Streets. Said Regulations are developed as guidelines for maximum protection to the public through uniform procedures and the orderly control of Utilities accessing the roadways; and

WHEREAS, from time to time experience has dictated the wisdom of amendments to Regulations and the Department has from time to time adopted such amendments; and

WHEREAS, it now appears desirable that the said Regulations as amended and all amendments thereto, as well as other changes, be included in an updating thereof;

NOW, THEREFORE, by virtue of the authority contained in Code Section 32-6-174 of the Official Code of Georgia Annotated, be it ordered by the Commissioner to adopt and make effective July 1, 2016 the "Utility Accommodation Policy and Standards, 2016"; and the same is hereby adopted as embodying the full and complete Regulations for the purposes therein stated in lieu of previous documents for such purposes and all amendments thereof until this date.

BE IT FURTHER ORDERED, that the Commissioner shall be authorized to grant waivers in connection with the requirements of these Regulations when deemed necessary in the public interest.

Done at Atlanta, Georgia, this 1<sup>st</sup> day of July '2016

APPROVED:

ATTEST:

  
Russell McMurry, P.E., Commissioner

  
Angela M. Whitworth, Treasurer



**This Page Intentionally Left Blank**



## **CHAPTER 1: DEFINITIONS AND TERMS**

Whenever the following abbreviations, terms, and phrases appear in this Manual, the intent and meaning shall be as follows:

### **Abbreviations:**

<b><i>AAR</i></b>	<b><i>American Association of Railroads</i></b>
<b><i>AASHTO</i></b>	<b><i>American Association of State Highway and Transportation Officials</i></b>
<b><i>ADA</i></b>	<b><i>American Disabilities Act</i></b>
<b><i>ADT</i></b>	<b><i>Average Daily Traffic</i></b>
<b><i>ANSI</i></b>	<b><i>American National Standards Institute</i></b>
<b><i>API</i></b>	<b><i>American Petroleum Institute</i></b>
<b><i>APWA</i></b>	<b><i>American Public Works Association</i></b>
<b><i>AREMA</i></b>	<b><i>American Railway Engineering and Maintenance-of-Way Association</i></b>
<b><i>ASCE</i></b>	<b><i>American Society of Civil Engineers</i></b>
<b><i>ASTM</i></b>	<b><i>American Society of Testing and Materials</i></b>
<b><i>ATMS</i></b>	<b><i>Advanced Transportation Management System</i></b>
<b><i>AWWA</i></b>	<b><i>American Water Works Association</i></b>
<b><i>BOARD</i></b>	<b><i>State Transportation Board</i></b>
<b><i>BUC</i></b>	<b><i>Broadband Utility Coordinator</i></b>
<b><i>CFR</i></b>	<b><i>Code of Federal Regulations</i></b>
<b><i>CIA</i></b>	<b><i>Contract Item Agreement</i></b>
<b><i>CRC</i></b>	<b><i>Clear Roadside Committee</i></b>
<b><i>DB</i></b>	<b><i>Design-Build</i></b>
<b><i>DBF</i></b>	<b><i>Design-Build-Finance</i></b>
<b><i>DBFM</i></b>	<b><i>Design-Build Finance-Maintain</i></b>
<b><i>DBFOM</i></b>	<b><i>Design-Build-Finance-Operate-Maintain</i></b>
<b><i>DUO</i></b>	<b><i>District Utilities Office</i></b>
<b><i>EPD</i></b>	<b><i>Department of Natural Resources, Environmental Protection Division</i></b>
<b><i>ELA</i></b>	<b><i>Easement Limited Agreement</i></b>
<b><i>ESA</i></b>	<b><i>Environmentally Sensitive Area</i></b>
<b><i>FAPG</i></b>	<b><i>Federal-Aid Policy Guide</i></b>

<b><i>FCC</i></b>	<b><i>Federal Communications Commission</i></b>
<b><i>FERC</i></b>	<b><i>Federal Energy Regulatory Commission</i></b>
<b><i>FFPR</i></b>	<b><i>Final Field Plan Review</i></b>
<b><i>FHWA</i></b>	<b><i>Federal Highway Administration</i></b>
<b><i>FRA</i></b>	<b><i>Federal Railroad Administration</i></b>
<b><i>Georgia811</i></b>	<b><i>Georgia 811 – Call Before You Dig</i></b>
<b><i>GDOT</i></b>	<b><i>Georgia Department of Transportation</i></b>
<b><i>GSWCC</i></b>	<b><i>Georgia Soil and Water Conservation Commission</i></b>
<b><i>GUCC</i></b>	<b><i>Georgia Utilities Coordinating Council</i></b>
<b><i>GUPS</i></b>	<b><i>Georgia Utilities Permitting System</i></b>
<b><i>ITS</i></b>	<b><i>Intelligent Transportation System</i></b>
<b><i>LMIG</i></b>	<b><i>Local Maintenance &amp; Improvement Grants</i></b>
<b><i>MOU/MOA</i></b>	<b><i>Memorandum of Understanding/Memorandum of Agreement</i></b>
<b><i>MUTCD</i></b>	<b><i>Manual on Uniform Traffic Control Devices</i></b>
<b><i>NEC</i></b>	<b><i>National Electrical Code</i></b>
<b><i>NESC</i></b>	<b><i>National Electrical Safety Code</i></b>
<b><i>NFPA</i></b>	<b><i>National Fire Protection Association</i></b>
<b><i>NJUNS</i></b>	<b><i>National Joint Utilities Notification System</i></b>
<b><i>O.C.G.A.</i></b>	<b><i>Official Code of Georgia, Annotated</i></b>
<b><i>OSHA</i></b>	<b><i>Occupational Safety &amp; Health Administration</i></b>
<b><i>P3</i></b>	<b><i>Public-Private Partnership</i></b>
<b><i>PDP</i></b>	<b><i>Plan Development Process</i></b>
<b><i>PFPR</i></b>	<b><i>Preliminary Field Plan Review</i></b>
<b><i>POA</i></b>	<b><i>Point of Attachment</i></b>
<b><i>PSC</i></b>	<b><i>Georgia Public Service Commission</i></b>
<b><i>STB</i></b>	<b><i>Surface Transportation Board</i></b>
<b><i>SUA</i></b>	<b><i>Standard Utility Agreement</i></b>
<b><i>SUO</i></b>	<b><i>State Utilities Office</i></b>
<b><i>TCP</i></b>	<b><i>Traffic Control Plan</i></b>
<b><i>TPA</i></b>	<b><i>Transportation Purpose Agreement</i></b>
<b><i>TRB</i></b>	<b><i>Transportation Research Board, National Research Council</i></b>

<b><i>UAP</i></b>	<b><i>Utility Adjustment Plan</i></b>
<b><i>UAS</i></b>	<b><i>Utility Adjustment Schedule (Work Plan)</i></b>
<b><i>USC</i></b>	<b><i>United States Code</i></b>
<b><i>URPN</i></b>	<b><i>Utility Relocation Procedure Notification</i></b>
<b><i>WTCS</i></b>	<b><i>Worksite Traffic Control Supervisor</i></b>
<b><i>WUCS</i></b>	<b><i>Worksite Utility Coordination Supervisor</i></b>

### Terms and Phrases:

**Access Control:** The condition whereby the rights of owners or occupants of land abutting the highway right-of-way, or other persons, to access, light, air, or view, in connection with a highway, is controlled by the Department of Transportation by special order.

- a. **Full Control of Access or Limited Access:** Means that preference is given to through traffic by prohibiting at-grade intersections or direct private driveway connections and providing access connections only at selected public crossroads by providing interchange connections.
- b. **Partial Control of Access or Controlled Access:** Means that preference is given to through traffic by limiting the number of public roads crossing at grade and generally restricting private driveway connections.

**Abandoned Facilities:** A utility facility taken out of service by the Utility but remaining physically in place. A Utility does not relinquish the ownership of an abandoned facility.

**Acceleration Lane:** A speed-change lane, including tapered areas, for the purpose of enabling a vehicle entering the roadway to increase its speed to a rate of which it can more safely merge with through traffic.

**Acceptable Condition:** The area is clear of debris and obstructions to conventional mowing and/or maintenance practice; plant materials conform to the *American Standard for Nursery Stock*, current edition, permit conditions, and the Department's Standard Specifications, current edition.

**Accommodation:** The installation of utility facilities along or across right-of-way with the intent that they will occupy and jointly use the right-of-way.

**Active Project:** A planned project that is included in the Construction Work Program and will be considered active until the date of its final acceptance.

**Adjustment:** The required modification to an existing utility facility to eliminate a conflict with an active project where the utility facility will generally be retained in the same location.

**Agreement:** A legal document that details the conditions of a Utility's rights and the procedures by which reimbursements, if any, will be made for relocations and adjustments.

**Agreement Modification Request:** Request for additional funds on an agreement due to approved change orders.

**Antenna:** Communications equipment that transmits or receives electromagnetic radio frequency (RF) signals used in the provision of wireless services.

**Application:** The documentation and process by which an Applicant submits a request to the Department to obtain a Permit.

**As-Built Plans:** Certified Record Drawings by the Utility Owner/Operator which depict the actual location of a utility facility after construction.

**Auxiliary Lane:** The portion of the roadway adjoining the traveled way used for access ramps, speed changes, turning, storage for turning, weaving, truck climbing, or other purposes supplementary to through traffic movement.

**Average Daily Traffic (ADT):** The average 24-hour traffic volume for a period of time, usually a year.

**Award:** The formal acceptance by the Department of a bid for highway construction work.

**Backfill:** Replacement of soil around and over a pipe, duct line, conduit, cable, or other underground structure or facility.

**Backslope:** The uphill slope from the flow line of the ditch on the opposite side of the ditch from the roadway.

**Bedding:** The subgrade soil or specified material and its surface as prepared to support a pipe, ductline, cable, conduit, or any other underground structure or facility.

**Best Management Practices (BMP's - Erosion & Sedimentation Control):** A collection of structural practices and vegetative measures which, when properly designed, installed, and maintained, will provide effective erosion and sedimentation control for all rainfall events in accordance with Georgia Environmental Protection Division (EPD).

**Betterments:** Any upgrading of the utility facility being relocated made solely for the benefit of, and at the election of, the Utility and not attributable to the highway construction.

**Bond:** A surety bond posted to ensure proper and complete construction and/or repair of a facility and the affected rights-of-way pursuant to a permit.

**Bore:** To excavate an underground cylindrical cavity for the insertion of a pipe or electrical conductor by a method other than plowing or trenching.

**Broadband Infrastructure:** Any buried, underground, or aerial facility, and any wireless or wireline connection, that enables users to send and receive voice, video, data, graphics, or any combination thereof.

**Broadband Infrastructure Entity:** Any entity that- (A) installs, owns, or operates broadband infrastructure; and (B) provides Broadband Services in a manner consistent with the public interest, convenience, and necessity, as determined by the State.

**Broadband Services:** A wired or wireless terrestrial service that consists of the capability to transmit at a rate of not less than 25 megabits per second in the downstream direction and at least 3 megabits per second in the upstream direction to end users and in combination with such service provides: (A) Access to the Internet; or (B) Computer processing, information storage, or protocol conversion.

**Buffer (State Waters):** An area along the course of any State Waters to be maintained in an undisturbed and natural condition.

**Buffer (Vegetation):** A defined area or corridor to be maintained in a natural, landscaped, or other condition as specified.

**Buried Cable:** Any and all cables, wires, conduit, pedestals, and/or other related facilities authorized in a permit for underground installation.

**Business Day:** A Calendar Day exclusive of Saturday, Sunday, and legal state holidays.

**Calendar Day:** Any day shown on the calendar, including weekends and holidays, beginning at 12:00 midnight.

**Cap:** A rigid structural element surmounting a pipe or other facility to provide protection and distribute loads.

**Carrier:** A pipe directly enclosing a transmitted substance such as liquid, gas, etc.; also, an electric or communication cable, wire, or line.

**Casing:** A larger protective pipe enclosing a carrier pipe, conduit, or duct.

**CATV:** Cable television.

**Certified Arborist:** A specialist certified by the International Society of Arboriculture in the planting and maintenance of trees.

**Certified Flagger:** A person providing temporary traffic control whose training and certification was obtained through a training organization that provides certified American Traffic Safety Services Association (ATSSA) or National Safety Council (NSC) programs, or from ATSSA or NSC themselves.

**Clear Zone:** The total roadside border area, starting at the edge of the travel way, available for safe use by errant vehicles. This area may consist of the shoulder, a recoverable slope, a non-recoverable slope, and/or a clear runout area. The desired width is dependent upon the traffic volumes and speeds, and on the roadside geometry.

**Coating:** Protective material applied to or wrapped around a pipe, ductline, conduit, cable, etc.

**Collocate or Collocation:** To install, mount, maintain, modify, operate, or replace one or more wireless facilities on, under, within, or adjacent to an existing structure or utility pole.

**Communication Facility:** The aggregate of equipment, such as telephones, facsimile equipment, conduits, cables, fiber optic cables, and other electronic equipment, used for various modes of transmission, such as light, digital data, audio signals, image and video signals.

**Conduit:** An enclosed tubular casing, often with multiple holes for the protection of wires, cables, or lines, usually jacketed and often extended from manhole to manhole.

**Conflict:** A conflict occurs when a utility facility requires relocation or adjustment to avoid damage or disruption or to comply with the regulations and accommodation requirements to accommodate construction, maintenance, operations, or other alterations the Department undertakes.

**Construction Engineering:** Engineering activities required on an active project to coordinate utility relocation work in accordance with the approved work plan and project schedule.

**Construction Work Program:** A listing of State and Federally funded projects approved by the State Transportation Board with one or more elements: Preliminary Engineering, Right-of-Way Acquisition, or Construction, scheduled in the current and next nine (9) fiscal years.

**Contract Documents:** Legal documents for Design-Build Projects, the Design-Build Documents, and for P3 Projects, the DBF Documents, DBFM Documents, or DBFOM Documents, or such other additional contractual documents identified in the P3 Project Agreement.

**Contract Item Agreement (CIA):** An Agreement used for including Utility work in the Department's project and performed by the Department's Contractor awarded by competitive bid.

**Contractor:** The individual, firm, corporation, or combination thereof, or governmental organization contracting with the Department for performance of prescribed work and, in the case

of a P3 Project, the Developer counterparty to SRTA, under a P3 Agreement administered by the Department. In a Design-Build project, the "Contractor" is the "Design-Builder".

**Conventional Highway:** A highway without access control.

**Cover (Depth):** Vertical distance, from the top of pipe or pipe's protective coating, casing, duct, cable, etc. to some specified surface such as pavement, ditches, or shoulders.

**Cradle:** A rigid structural element below and supporting a pipe carrier or casing.

**Crown Reduction or Cutting Back:** The specific cutting back of a branch or leader to a lateral branch at least one-third to one-half diameter of the cut being made. Pruning designed to reduce the crown of a tree or individual branch. Sometimes this is referred to as heading back, drop crotch pruning, natural pruning, lateral pruning, or directional pruning in an effort to keep the natural symmetry of the tree on the sides as well as the top.

**Damages (as pertains to Mediation):** The actual cost that covers injury or economic loss due to documented damages resulting solely from failure on the part of the Utility to comply with requirements of the submitted and approved Work Plan under the control of the Utility.

**DBF Documents:** The documents specified in the P3 Agreement that, together with the terms and conditions in the P3 Agreement document, comprise the full contract between SRTA and a Developer to design, build and finance a P3 Project.

**DBFM Documents:** The documents specified in the P3 Agreement that, together with the terms and conditions in the P3 Agreement document, comprise the full contract between SRTA and a Developer to design, build, finance and maintain a P3 Project.

**DBFOM Documents:** The documents specified in the P3 Agreement that, together with the terms and conditions in the P3 Agreement document, comprise the full contract between SRTA and a Developer to design, build, finance, operate and maintain a P3 Project.

**Deceleration Lane:** A speed-change lane, including tapered areas, for the purpose of enabling a vehicle that is making an exit turn from a roadway to slow to a safe turning speed after it has left the mainstream of faster-moving traffic.

**Delay Cost:** Costs incurred by the Contractor and approved by the Department, which are caused by, or which grow out of, the failure of the Utility to carry out and complete its work in accordance with the approved Work Plan or in a timely and reasonable manner, if a Work Plan, or revised Work Plan, was not submitted.

**Department:** The Department of Transportation of the State of Georgia.

**Designee:** The individual or company to whom the Department delegates certain authority for the administration of the mediation process.

**Design-Build Agreement** The contract between the Department and a Design-Builder to design and Construct a DB Project.

**Design-Build Documents** The documents specified in the Design-Build Agreement that, together with the terms and conditions in the Design-Build Agreement document, comprise the full contract between the Department and a Design-Builder.

**Design-Build Project:** A project in which the SRTA or GDOT contracts with a Design-Builder for the design and construction of a public transportation project.

**Design-Builder:** The party awarded a contract to design and construct a DB Project, including Utility Adjustments.

**Developer:** The party awarded a contract to design, construct, finance and potentially operate and maintain a P3 Project. A Developer is a Contractor for purposes of this UAM. If the Developer enters into a contract with third party or parties for the design, construction, or design and construction of the P3 Project, the term “Contractor” as used in this UAM shall apply to such third party(ies) as appropriate in the context of the given provision of this UAM.

**Direct Burial:** Installing a utility underground without encasement, typically by plowing or trenching.

**Distribution Line:** That part of a utility facility connecting its transmission lines with its individual customers or with the service lines of the individual customers.

**District:** A management region defined by the Department of Transportation.

**Drain:** Appurtenance to discharge liquid contaminants from casings.

**Drainage Structure:** Any structure providing drainage for the roadway other than a bridge.

**Driving:** A small pipe with a pilot shoe can be driven through compressible soils by a steady thrust, hammering or vibrating. Pipe must be smooth and uncoated, and, hence, a casing or corrosion-resistant carrier must be used. Long drives may wander far from the desired line and grade; generally, the length of this installation shall not exceed 30 feet.

**Dry Boring:** A method of boring where casing or carrier pipe can be jacked through bores carved progressively ahead of the leading edge of the advancing pipe as soil is moved through the pipe, normally with an auger that has been placed inside the pipe. Limited directional change can be achieved with new advances in equipment.

**Duct:** An enclosed tubular casing for protecting wires, lines, or cables, often flexible or semi-rigid.



**Easement:** A right, other than the acquisition of title, acquired to use or control property for a designated purpose.

**Easement Limited Agreement (ELA):** An Agreement used to document and preserve the existing reimbursement rights of the Utility for future projects and for modifying the Utility's right-of-way or easement right to the extent that all future installation, operation, and maintenance of the Utility's facilities within the highway right-of-way shall be in accordance with this Manual, current edition.

**Effectively Destroy:** To cause, allow, or permit any act that will cause a tree to die or go into a period of unnatural decline within a period of 1 year from the date of the act. Acts which may effectively destroy a tree include, but are not limited to: damage inflicted unto the root system by heavy machinery; excessive pruning; severing the leader or leaders; stubbing mature wood; changing the natural grade above the root system or around the trunk; damage intentionally inflicted on the tree permitting infection or pest infestation; application of herbicides or other chemical agents; intentional fire damage to the tree permitting infection or pest infestation; the infliction of a trunk wound that is 50% or greater of the circumference of the trunk; or the removal of sufficient canopy to cause the unnatural decline of the tree.

**Emergency:** A sudden or unforeseen occurrence involving a clear or imminent danger to life, health, property; or interruption of Utility services; or repairs to transportation facilities that require immediate attention.

**Encasement:** A structural element surrounding a pipe carrier or casing.

**Encroachment:** Unauthorized use of highway right-of-way or easements as for signs, fences, building, utilities, parking, storage, etc.

**Environmentally Sensitive Areas (ESAs):** Environmentally Sensitive Areas include, but are not limited to, wetlands, flood plains, archaeological or historic sites, areas with stability or settlement problems, areas with artesian conditions, animal/or plant communities, and landscapes or geologic formations with exemplary, unique, rare or threatened/endangered characteristics.

**Erosion Control:** Practices used to minimize soil loss and the discharge of turbid runoff. Erosion control practices shall be in accordance with Local, State and Federal regulations.

**Escalation Process:** The process which raises an issue, action or concern to successive levels of Departmental management for resolution, particularly when resolution cannot be reached at the District level. The Parties at the District level should always strive to make decisions and address items at the lowest level possible.

**Exception:** Utility installations, adjustments, and relocations that are not in accordance with this Manual.

**Executive Order:** Whenever the Department deems it necessary and in the public interest to have a new or existing public road designated as part of the State Highway System, whether as additional mileage or as part of a substitution or relocation, the Department may designate such road to be a part of the State Highway System. If the road proposed to be designated is a part of either a county road system or a municipal street system, the Department shall give written notice to the county or municipality of the effective date that such road shall become part of the State Highway System. Any change on the State Highway System by designation shall be recorded on the official map and in the written records of the State Highway System, as provided for in subsections (a) and (b) of O.C.G.A. § 32-4-2.

**Exotic Pest Plants:** Non-native, invasive plants also called noxious weeds, which are a problem in natural communities and ecosystems on public and private land. In general, these plants have the potential to disrupt the natural landscape-invading forests, glades, barrens, wetlands and other natural areas as well as stifle agriculture production and timber growth. Examples: Kudzu (*Pueraria lobata*), Princess tree (*Paulownia tomentosa*), Privet (*Ligustrum sinense* and *vulgare*), Mimosa (*Albizia julibrissin*), Japanese honeysuckle (*Lonicera japonica*).

**Expressway:** A divided arterial highway for through traffic with partial access control and, generally, with grade separations at major intersections.

**Extraordinary Circumstances:** Circumstances, other than normal operating conditions, which exist and make it impractical or impossible for a Utility to comply with the provisions of this section/policy. Such extraordinary circumstances may include, but shall not be limited to, hurricanes, tornadoes, floods, ice and/or snow, and acts of God.

**Final Billing:** A detailed summary of the actual costs incurred by the Utility, including documentation necessary to verify the amounts expended in connection with the relocation of utility facilities for a transportation project.

**Flexible:** A plastic, fiberglass, or metallic pipe having large ratio of diameter to wall thickness which can be deformed without undue stress.

**Flowable Fill:** A low strength, slurry-like fill material primarily used in below grade applications, such as utility trenches, where low strength and ease of placement are required. It is typically placed using conventional ready-mix concrete trucks.

**Freeway:** An expressway with full control of access.

**Frontage Road:** A street or road auxiliary to and located on the side of an expressway or freeway for service to abutting property and for control of access.

**Georgia Utilities Permitting System (GUPS):** A totally electronic, web-based system which allows Utilities the ability to transfer a completed utility permit application package to the Department for review via the internet.

**Grounded:** Connected to the earth, or to some extended, conducting body which serves instead of the earth, whether the connection is intentional or accidental.

**Grout:** A sand-cement mortar; may be modified with fly ash.

**Handhole:** A pull box, junction box, or an access opening in an underground system which is used for the purpose of splicing or pulling cables.

**Hatrack or Topping:** To flat cut the top or sides of a tree or the severe reduction of branches without consideration for specifications for cutting back in an effort to keep the natural symmetry (sides as well as top) of the tree; to sever the leader or leaders or to prune a tree by the stubbing of mature wood.

**Highway, Street or Road:** A general term denoting a public way for the transportation of people, but primarily for vehicular travel, including the entire area within the right-of-way.

**Horizontal Clearance:** The lateral distance from edge of traveled way to a roadside object or feature.

**Horizontal Directional Drilling:** A method of drilling where a remotely controlled cutting head is pushed from an entry pit through the soil under the surface. Changes in line and grade can be made as the operation proceeds. The cutting head is tracked electronically from the surface. Conduits, cables, or casings are pulled back through the opening, sometimes following an enlarging reamer. Drilling fluids are usually used for lubrication and to support the opening until the conduit, casing, or cable is pulled into place. Hydraulic cutting heads that remove the soil by washing or jetting are not allowed.

**Inspector:** The Department's authorized representative assigned to make detailed inspection of agreement or permit performance.

**Intelligent Transportation System (ITS):** A system used to collect, store, process, distribute, and use data about the movement of vehicles, people, and goods to enhance safety and security, reduce traffic congestion, save energy, and in other ways improve generally the performance of the State's highways. Two subsystems of ITS are Advanced Traveler Information System (ATIS) and Advanced Transportation Management System (ATMS).

**Inter-Exchange Carrier:** A carrier of voice and data services which uses the right-of-way to transport inter-LATA voice and data signals using fiber optics or copper placed in the right-of-way, and who provides Communications Service.

**Inter-LATA Telecommunication Services:** Telecommunications services that originate in one LATA and terminate in another LATA. Such services may pass through several LATAs before termination.

**Jacket:** Encasement by concrete poured around a pipe.

**Jacking:** Pushing a pipe horizontally under a roadway by mechanical means with or without boring.

**Joint Use:** The use of pole-lines, trenches, or other facilities by the Department, two or more Utilities, or a combination thereof.

**LATA or Local Access Transport Area:** A geographical service area where a local telephone company is authorized to provide communications services.

**Land-Disturbing Activity:** Any activity which may result in soil erosion from water or wind and the movement of sediments into State Waters or onto lands within the State, including, but not limited to, clearing, dredging, grading, excavating, transporting, and filling of land but not including agricultural practices.

**Locate request:** A communication between an excavator and Georgia 811 in which a request for locating utility facilities is processed.

**Locates:** An information gathering process, which may or may not involve a formal survey, to identify and define the position of a utility. This information is used to determine the proximity of a utility to other features so as to prevent conflict during construction.

**Long-side Service:** A service line that requires crossing of the traveled way.

**Maintenance:** The work required to keep an existing utility facility in good state of repair without adding to its physical makeup or changing its physical capacity.

**Make-Ready Work:** All work, as reasonably determined by the pole owner, to prepare an existing Pole to receive Licensee's Attachments and to meet the NESC, or other reasonable requirements of the pole owner. Make-Ready Work also includes, but is not limited to, inspections, engineering, permitting and construction, but does not include the owner's routine maintenance, correcting existing violations, or make right work.

**Make-Right Work:** All work, as reasonably determined by the pole owner, to bring an existing Pole up to the standards, etc. as defined by the NESC, or any other reasonable requirements of the pole owner. Make-Right Work also includes, but is limited to, inspections, engineering, permitting, and construction.

**Manhole:** An opening to an underground system which workers or others may enter for the purpose of making installations, inspections, repairs, connections, tests, etc.

**Manual:** The State of Georgia Department of Transportation's *Utility Accommodation Policy and Standards Manual* referenced in this document as Manual or Utility Manual.

***Manual on Uniform Traffic Control Devices, Current Edition (MUTCD):*** A document produced by the National Committee on Uniform Traffic control Devices for the purposes of unifying standards applicable to different classes of roads and street systems.

**Mechanized Excavating Equipment:** All equipment which is powered by any motor, engine, hydraulic, or pneumatic device, and which is used for excavating.

**Median:** The portion of a divided highway separating the traveled ways for traffic in opposite directions.

**Mediation:** A process of dispute resolution to be employed by the Department and Utilities to resolve conflicts.

**Mediation Board:** A three-person board created by the authority O.C.G.A. § 32-6-171 to resolve disputes between the Parties.

**Micro Wireless Facility:** Wireless facility not larger than 24 inches in length, 15 inches in width, 12 inches in height and may have an exterior antenna no longer than 11 inches.

**Miscellaneous Facility:** The facility authorized in the permit, other than pole-line, buried cable, pipe line, or miscellaneous operations.

**Miscellaneous Operations:** The performance of miscellaneous operations as described in the permit.

**Mitigation/Restoration:** Vegetative restoration of the site to make the impact of the vegetation management activities milder or less severe. Vegetation management activities often involve forest canopy and ecosystem losses and require mitigation on site to the fullest extent possible.

**Natural Ground Surface:** The ground surface in its original state before any grading, excavating or filling.

**Normal:** Crossing at a right angle.

**Oblique:** Crossing at an acute angle.

**Overfill:** Backfill above a pipe, ductline, conduits, cables, etc.

**Overhead/Subsurface Utility Engineering (SUE):** According to the *ASCE Standard Guideline for the Collection and Depiction of Existing Subsurface Utility Data*, current edition, SUE is "a branch of engineering practice that involves managing certain risks associated with utility

mapping at appropriate quality levels, utility coordination, utility relocation design and coordination, utility condition assessment, communication of utility data to concerned parties, utility relocation cost estimate, implementation of utility accommodation policies, and utility design.”

**Owner:** The individual, company, government agency, etc. having ownership and responsibility for a utility facility.

**P3 Project:** A project in which SRTA contracts with a Developer for the design, construction, financing and potentially operation and maintenance of a public transportation project.

**P3 Project Agreement:** The contract between SRTA and a Developer, and administered by the Department, for a P3 Project.

**Parties:** The Department, the Utility; and the Contractor may be a party (or parties) where applicable.

**Pavement Structure:** The combination of subbase, base course, and surface course placed on a subgrade to support the traffic load and distribute it to the roadbed.

**Permit:** The legal document by which the Department regulates the use and/or occupancy of the right-of-way for a Utility. The term permit also may include all details, plans, special provisions, etc.

**Piercing Tool:** A pneumatically-powered cylinder attached to an external air supply which is inserted in a pilot hole at proper depth and grade. The pneumatic hammering action of the head of the tool propels the cylinder through the soil. A wire, cable, casing, or carrier pipe is pulled back through the opening by the attached air supply line. Current equipment limits openings to about 50 mm or 2 inches in compressible soils.

**Pipe:** A tubular product made as a production item for sale as such. Cylinders formed from plate in the course of the fabrication of auxiliary equipment are not pipe as defined here.

**Pipeline:** Any and all pipelines, hydrants, valve boxes, manholes, conduits, casings, and/or related fixtures authorized in the permit.

**Plan Development Process (PDP):** The Department’s Policy 4050-1; this document outlines the current process of project development from project identification through construction award to the Contractor.

**Plowing:** Direct burial of utility lines by means of a “plow” type mechanism which breaks the ground, places the utility line, and closes the break in the ground in a single operation.

**Pole Attachment Permit:** A form which grants permission to the Department to install described facilities to and upon the Company’s pole or poles.

**Pole-line:** Any and all poles, wires, guys, anchors, and/or related fixtures authorized in the permit.

**Political subdivision:** A County, City, or Town chartered by the General Assembly of Georgia.

**Preliminary Engineering:** Engineering activities required during the Plan Development Process of an active project that provides for all the necessary plans, documents, and any other supporting information necessary to determine utility impacts and the appropriate coordination.

**Pressure:** Relative internal pressure.

**Prior Rights:** A prior vested right whereby a Utility is eligible for compensation for the relocation of utility facilities whose occupancy predates existing or proposed right-of-way.

**Private Lines:** Facilities that are not owned by government entities, inclusive of any substantially owned or controlled subsidiary, and are generally considered facilities which are devoted exclusively to private use and not directly or indirectly serving the general public.

**Project Manager:** The Department's representative, typically in a design office, in responsible charge of a project. The Project Manager makes the day-to-day engineering decisions and is responsible for steering, coordinating, and managing a project through the Department's Plan Development Process. The Project Manager may or may not be the individual doing the actual design.

**Prune:** The removal of plant parts, dead or alive, in a careful and systematic manner so as to not damage other parts and the health of the plant.

**Public Utilities:** Generally considered those utility facilities which directly or indirectly serve the general public by conveying a product, power, or communication from the Utility to a customer and includes utility-type facilities that are owned by or dedicated to a governmental agency for its own use.

**Regulator Stations (sites):** An appurtenance typically associated with gas pipelines for the control of pressure to a lesser pressure distribution main.

**Relocation:** The adjustment of utility facilities required for the construction, repair, improvement, maintenance, safe and effective operation, alteration or relocation of all or any portion of the highway. It includes removing and reinstalling the facility, including necessary temporary facilities, acquiring necessary right-of-way on the new location, moving, rearranging or changing the type of existing facilities, and taking any necessary safety and protective measures. It shall also mean constructing a replacement facility that is both functionally equivalent to the existing facility and necessary for continuous operation of the utility service, the project economy, or sequence of highway construction.

**Repair:** The work required by failure of a utility facility, and which essentially consists of replacement in kind and replacement in place of components of the facility.

**Restoration:** The reconstruction of the highway disrupted by the construction of, maintenance, or repair of a utility facility with the resultant effects by which the highway is returned to a condition as good as or better than its original condition.

**Right-of-Way:** A general term denoting land, property, interest therein, usually in a strip acquired or devoted to transportation purposes.

**Rigid:** A general term denoting pipes distressed by diametric deflection exceeding 1.0%. (Such as welded or bolted metallic pipe and reinforced, prestressed, or pretensioned concrete pressure pipe.)

**Roadbed Structure:** The portion of highway that includes the pavement structure, shoulders and front slopes.

**Roadside:** A general term denoting the area adjoining the outer edge of the roadway. Extensive areas between the roadways of a divided highway may also be considered roadside.

**Roadway:** The portion of a highway, including shoulders, for vehicular use. A divided highway has two or more roadways.

**Safety Rest Area:** A roadside area, with parking facilities separated from the roadway, provided for motorists to stop and rest for short periods. It may include drinking water, toilets, tables and benches, telephones, information and other facilities for travelers.

**Scenic Overlook:** A roadside area provided for motorists to stop their vehicles beyond the traveled way, primarily for viewing the scenery in safety.

**Semi-rigid:** A general term denoting tolerating diametric deflection up to 3.0%. (Such as large diameter concrete and metallic pipe).

**Service Lines:** Generally considered a special class of private lines. Whether the public utility facility is on or off highway right-of-way, the sole reason for a service line to be on the highway right-of-way is to facilitate its connection with a public utility.

**Short-side Service:** A service line that does not require the crossing of the traveled way.

**Shoulder:** The portion of the roadway continuous with the traveled way for accommodation of stopped vehicles, for emergency use, and for lateral support of base and surface courses.



**Shrub:** A woody plant smaller than a tree usually having multiple permanent stems branching from or near the ground.

**Sidefill:** Backfill alongside a pipe, ductline, conduits, cables, etc.

**Site:** Includes any vegetation activity (i.e., mowing, chemical control, pruning, and tree removal), on or adjacent to the right-of-way, being performed under an approved vegetation permit.

**Slab, floating:** A slab between, but not contacting, the pipe and the pavement.

**Sleeve:** A short casing through a wall, pier, abutment, or similar highway structure.

**Small Wireless Facility:** Wireless facility consisting of an antenna of no more than six cubic feet in volume and not exceeding 28 cubic feet when accounting all associated equipment.

**Special Provisions:** Additions or revisions to the *Utility Accommodation Policy and Standards Manual* or the Department's Standard or Supplemental Specifications, current edition, applicable to an individual permit, agreement or active project.

**Standard Specifications:** The Department's *Standard Specifications, Construction of Transportation Systems*, current edition, including approved amendments thereto.

**Standard Utility Agreement (SUA):** An Agreement providing for relocation or adjustment work to be performed by the Utility and/or its consultant or contractor and modification of easement limited provisions (See Section 4.0.B.3), if applicable. To the extent practical, reimbursement by the Department will be made based upon the Department's specifications, agreements and forms or consultant and construction contract work. The payment method may be actual cost, unit price, or lump sum as appropriate (see Section 4.7, Estimate Requirements).

**Surety:** The corporate body or bodies bound with and for the Utility for the full and complete performance of the provisions in the permit.

**Team:** Consists of GDOT personnel including but not limited to District Utilities Engineer or designee, Project Manager, District Signal Engineer; Designer; Utility Owners; and Local Government representatives.

**Telecommunication Facility:** Any communication facility as defined herein.

**Test Hole:** The excavation made to determine, measure, and record the presence of a utility facility. The term may also be associated with the repair of certain underground facilities, see Section 5.2.F.2.c.

**Timber Pole:** A wooden pole that conforms to GDOT 925 Specifications.

**Toe of Slope:** The bottom of a slope of a fill or cut area, usually the lowest point of the slope.

**Traffic Control Plan:** Documentation of how a safe flow of traffic will be conducted through an area in which utility work is being performed.

**Transmission Lines:** The part of a utility facility connecting its main energy or material source(s) with its distribution system, to which individual customers usually are not connected.

**Transportation Purpose Agreement (TPA):** When the Department, as part of a project, proposes to install traffic signals, signs, or other traffic control devices on or within a utility facility, or requires a Utility to service a highway facility, and such installations will require modifications to or the addition of new utility facilities, the Department will reimburse such modifications or new utility installations through this type of agreement. See Sections 4.12 or 4.13 for all applicable provisions that will be required.

**Traveled Way:** The portion of the roadway used for the movement of vehicles, exclusive of shoulders and auxiliary lanes.

**Tree/Tree Canopy:** Any living, self-supporting, dicotyledonous or monocotyledonous woody perennial plant which normally grows to an overall height of no less than 10 feet in Georgia. Tree Canopy is the upper portion of the tree consisting of limbs, branches and leaves.

**Trenched:** Installed in a narrow open excavation.

**Trenchless Technology:** The use of directional boring, horizontal drilling, tunneling, and other techniques used in the construction or installation of underground portions of facilities to minimize disruption and damage to right-of-way.

**Underpass:** A passage running underneath a highway or railroad.

**Use and Occupancy Agreement:** The document (permit or agreement) by which the Department approves the use and occupancy of highway right-of-way by utility facilities or private lines.

**Utility:** Any privately, publicly or cooperatively owned line, facility, or system for producing, transmitting or distributing communications, cable television, power, electricity, light, heat, gas, oil products, water, steam, clay, waste, storm water not connected with highway drainage, and other similar services and commodities, including river gages, fire and police signals, and street lighting systems, which directly or indirectly serve the public. The term "Utility", when capitalized, may also be used to refer to the owner of any above described utility or utility facility.

**Utility Accommodation Policy:** A statement of the policies and procedures used by the Department to regulate and accommodate Utilities on public right-of-way; Title 23 of the Code

of Federal Regulations (CFR), Part 645.215 (b), the Federal Highway Administration (FHWA) requires the Department to develop its own Utility Accommodation Policy in order to receive federal funding. The policies, procedures and standards are contained in this Manual or as an addendum as needed.

**Utility Adjustment Schedule (UAS):** The form used by a Utility to document the work and time required to complete relocations or adjustments as part of a highway project. The work plan is required in accordance with O.C.G.A. § 32-6-170.

**Utility Driveways:** Driveways for access to utility sites such as water tanks, water meters, sewer lift stations, telephone service cabinets, power substations, or gas regulator sites.

**Utility Facility:** The term "utility facility" shall include, but is not limited to, any and all poles, wires, guys, anchors, buried cable, conduit, pedestals, pipe lines, hydrants, valve boxes, manholes, casings, river gages, and related fixtures authorized in the permit or agreement.

**Utility Tunnel:** An underpass for one or more utility lines.

**Vegetation:** All woody and herbaceous plants either naturally occurring or planted.

**Vegetation Management:** All planned work activities relating to landscape and roadside development on the right-of-way. These activities may include the removal and/or pruning of trees or other vegetation, landscape planting, construction and any maintenance management of their related features (i.e. mowing, chemical control and pruning and tree removal).

**Vent:** An appurtenance to discharge gaseous contaminants from casings.

**Walled:** Partially encased by concrete poured alongside a carrier or casing.

**Wash Factor:** The product being transported or carried in a pipeline facility is of a liquid form and has the capacity to remove roadway material from around the pipeline if a leak occurred. Not to include service lines one (1) inch or less.

**Wireless Facility:** Equipment at a fixed location that enables wireless communications between user equipment and a communications network.

**Wireless Support Structure:** Support structure that exclusively designed to support small cell antennas and/or wireless facilities and/or has a primary function as a support for small cell antennas, wireless facilities, and/or related auxiliary equipment.

**Work Plan:** A set of documents that consists of, but is not limited to, the Utility relocation plans, cost estimates, and the GUPS Permit including the Utility Adjustment Schedule to be submitted by each utility facility owner who has facilities that are required to be relocated or adjusted to accommodate the said project construction.

**This Page Intentionally Left Blank**

## **CHAPTER 2: AUTHORITY, PURPOSE, AND SCOPE OF REGULATIONS**

### **2.1 AUTHORITY TO REGULATE**

**2.1.A. Public Road Encroachment Prohibited** – The Official Code of Georgia, Annotated, O.C.G.A. § 32-6-1, provides that "(i)t shall be unlawful for any person to obstruct, encroach upon, solicit the sale of any merchandise on, or injure materially any part of any public road." (Emphasis added). O.C.G.A. § 32-1-10 provides that, "(a)ny person who violates any of the provisions of this Title for which no specific penalty is provided, whether or not such act or omission is expressly declared elsewhere in this Title to be unlawful, or who violates any of the rules and regulations issued under authority of and in accord with the provisions of this Title, shall be guilty of a misdemeanor...", and further provides that the Department "shall have the right to enjoin any act or omission so punishable as a misdemeanor...". Further authority for enforcement against encroachment is provided in O.C.G.A. § 32-1-9 under which it is declared to be "the duty of all State and Local law enforcement officers to enforce any provisions of this Title which states that any act or omission is unlawful."

**2.1.B. Department Regulation Authorized** - Notwithstanding the above cited restriction against encroachment, the State Legislature has given the Department the authority to issue regulations to allow installation of utility facilities within the right-of-way. Provisions for regulation of utility encroachments by the Department are contained in O.C.G.A. § 32-6-174 which states that "The Department may promulgate reasonable regulations governing the installation, construction, maintenance, renewal, removal, and relocation of pipes, mains, conduits, cables, wires, poles, towers, tracks, traffic and other such signals, and other equipment and appliances of any Utility in, on, along, over, or under any part of the State Highway System or any public road project which the Department has undertaken or agreed to undertake or which has been completed by the Department pursuant to its authority."

**2.1.C. Basis for Policies and Standards** - This Manual has been established after careful review of standards and practices of other government agencies, recommendations of national associations of highway, public works, and utility officials concerned with utility accommodation policies, and national standards and codes governing Utilities. The provisions are further based on

the prior experience of the Department in its utility permit operations and the judgment of the Department's engineers as to adequate and proper design, construction, and operation practices. These policies and standards are in conformance with other standards under which the Department operates and are considered to constitute reasonable requirements for the protection of the public interest in accommodating Utilities on the right-of-way.

## **2.2 AUTHORITY TO REIMBURSE**

Titles 32-6-170 and 32-6-173, of the O.C.G.A., authorize the Department to pay the cost of removing, adjusting, and relocating any public utility given certain provisions are met. Such provisions for reimbursement are detailed in Section 4.2 of this Manual. However, all such costs the Department is authorized to pay or participate in shall be limited to the costs of removing, adjusting, and relocating those facilities which are physically in place and in conflict with proposed construction and, where replacement is necessary, to the costs of replacement in-kind. That proportion of the costs representing improvement or betterment in a facility shall be excluded from the costs eligible for payment or participation by the Department, unless required to meet current laws, regulations, industry standards or codes.

**2.2.A. Publicly-Owned Facilities** - The O.C.G.A. § 32-6-170, provides that the Department may pay the cost of removing and relocating any utility facility owned by a municipality, county or State agency, or by an authority created under the laws of the State of Georgia pertaining to public Utilities, when such removal and relocation is made necessary by the construction or maintenance of any public road by the Department. Payment may be made under this Code Section without regard to provisions of any existing permits or agreements. Prior approval for reimbursement is required as stated in Section 4.2 of this Manual.

**2.2.B. Reimbursement for the Public Interest** - The O.C.G.A. § 32-6-170, provides that the Department may pay the cost of removing relocating or making the adjustments to any utility facility owned by a public utility without regard to whether such facilities were originally installed upon the right-of-way of the State Highway System, a county road system, or a municipal street system, where the Department has made the determination of the following:

1. Such reimbursement is in the best interest of the public and necessary in order to expedite the staging of the project;

AND

2. The costs of the removal, relocation, or adjustment of such utility facilities can be included as part of the contract between the Department and the Department's contractor for the associated Department project.

Payment may be made under this Code Section without regard to provisions of any existing permits or agreements. Prior approval for reimbursement is required as stated in Section 4.2 of this Manual.

**2.2.B.1. Utility Facilities Holding a Property Interest** - For those installations where the Utility is determined to hold a property interest, the measure of damages for the adjustment or relocation of the facilities is construed to be the net cost (including the cost of replacement right-of-way and proper credits for salvage) to restore the function of the Utility, and payment, therefore, is made in lieu of the market value approach of determining the value of property taken. Prior approval for reimbursement is required as stated in Section 4.2 of this Manual.

## **2.3 PURPOSE OF MANUAL**

**2.3.A. Policies and Standards** - The purpose of this Manual is to establish and prescribe uniform policies and standards for accommodation of utilities within the right-of-way, to provide a basis for the planning of utility installations, and to establish procedures and controls for the issuance of permits. A permit system for the accommodation of utilities makes known the intent of the Utility to carry out work within the right-of-way, stipulates the nature and extent of such right-of-way work, provides an administrative means to coordinate the use of right-of-way space and to hold the Utility responsible for such authorized work, and provides a means to grant approval for the authorized work and establish records of all utility installations, certain maintenance activities (see Section 3.8 in this Manual), and operations within the right-of-way.

**2.3.B. Certification Acceptance** - These policies and standards further serve to document the practice which the Department will follow in construction of federal-aid projects under its certification acceptance plan with the FHWA, as permitted by Title 23 United States Code (USC) Chapter 1, Sections 101 (e), 106, 117 and Chapter 3, Section 315, and thereby eliminate the requirement for Federal reviews of individual Departmental actions on all projects exempt from full FHWA oversight.

**2.3.C. Revision of Published Policies and Standards** - This *Utility Accommodation Policy and Standards Manual* supersedes and replaces the Manual of the same title, dated 2009, and all other publications of the Department of Transportation relative to policies and standards governing the relocation, adjustment and accommodation of Utilities within the right-of-way, which may be in conflict herewith.

## **2.4 SCOPE OF APPLICATION**

**2.4.A. State Highway System** - All Utilities, whether privately or publicly owned, will be required to comply with the policies and standards of this Manual when occupying or crossing any part of the right-of-way of the State Highway System.

### **2.4.B. Local Roads and Streets** -

**2.4.B.1. Utility Accommodations** - The responsibility of regulating Utilities on Local roads and streets falls under the jurisdiction of the political subdivision. To ensure reasonably uniform practices throughout the State, the Department encourages adoption of this Manual for relocation, adjustment and accommodation of utilities or a similar policy so long as it is not more restrictive than the Department's; in accordance with O.C.G.A. § 32-4-42 and 32-4-92.

**2.4.B.2. Active Projects** - When the Department participates in the funding of Local projects by allocation of State or Federal funds, the political subdivision often becomes the implementing agency or agrees to support the project by other means. The Department will review Local action for compliance with all requirements of Federal and State laws and Executive Orders as they pertain to utility accommodations, relocations and adjustments. If the political subdivision has agreed to be responsible for any phase of an active project, with regards to utility accommodation, the political subdivision shall ensure the requirements of this Manual are satisfied. In order for the Department to certify authorization of funds for these projects, written correspondence shall be required from the political subdivision stating that all utility coordination has occurred and that any required agreements for reimbursable utility relocations have been completed. Failure by the political subdivision to comply with all requirements may jeopardize the



Department's participation in the project funding. See *Locally Administered Projects Utility Coordination White-Paper* on GDOT's Utilities webpages for additional information.

- 2.4.B.3. Other Projects** - When the Department participates in the funding of other projects identified under the Transportation Enhancement Program or the Local Maintenance & Improvement Grant (LMIG) Program (i.e. County, City, and Local Contracts, etc.) no portion of the authorized funds will be used for the relocation of utilities.

## **2.5 LIMITATIONS ON RIGHT-OF-WAY OCCUPANCY**

- 2.5.A. Protection of Roadway** - It is the policy of the Department that no Utility may occupy the right-of-way unless sufficient space is available so that the free flow and safety of highway traffic is not unduly impaired and the utility installation does not prevent the Department from reasonably maintaining the highways, structures, traffic control devices and other appurtenant facilities, and further provided that maintenance and operations of the Utility do not jeopardize the highway structure or the maintenance thereof.

- 2.5.A.1. Existing Utility Pole Obstacles** - The Department intends to provide reasonable protection from existing utility poles to motorists through the adoption of a Utility Pole Safety Program. This action is taken to provide a motorist who leaves the travel way a reasonable opportunity to recover control of his vehicle and avoid crashes.

The most desirable treatment is the removal or relocation of pole(s) from the clear zone. Where this is not practical, acceptable treatments such as making the pole(s) breakaway or shielding the pole(s) so that vehicles will not hit it should be investigated as per Chapter 8 of this Manual. The criteria are to be applied on a site-by-site basis for individual pole(s) or conditions. The appropriate clearances and treatments will be based upon an evaluation of safety, economics, and other factors pertinent to an engineering analysis. In all cases, the clearances and treatments are guidelines rather than absolute standards.

The establishment of a systematic approach to reduce or eliminate unsafe utility pole facilities from that portion of the right-of-way determined to be the Clear Zone is a collaborative effort by the Department and the Georgia Utilities Coordinating Committee's (GUCC) subcommittee called the Clear Roadside Committee (CRC).

Procedures and requirements for participating in the Utility Pole Safety Program are contained in Chapter 8 of this Manual.

## **2.5.B. Highways with Access Control -**

**2.5.B.1. Interstate** - New utility installations will not be permitted longitudinally within the control of access lines of any Interstate System, except that, in special cases, such installations may be permitted under strictly controlled conditions. Utility facilities will not be allowed to be installed longitudinally within the median area.

**2.5.B.2. Limited Access Highways** - Under the Department's policies there are different levels of access control. The following guidelines shall be used for utility installation requests for controlled access highways.

**2.5.B.2.a. Highways Built on New Location with Limited Access** - It is anticipated that these highways will have the following characteristics. Access to these highways will be provided only at major crossroads. Driveways will not be provided to adjacent property. Frontage roads will be used where access to adjacent property is required. Longitudinal installation of utilities will not be permitted along these highways. The Commissioner must approve any exceptions to this rule. Where exceptions are requested, there must be a showing by the Utility that denial of a permit would cause extreme hardship. Such requests for exception will be considered only for transmission facilities without service connections or laterals that would extend across access control lines.

**2.5.B.2.b. Existing Highways Converted to Limited Access** - These highways may have a limited number of driveways to serve property along the road in addition to access at major crossroads. Existing utility facilities will usually be in place and will be required to serve residences and businesses along the road.

Existing utilities, including service lines, may be retained within the right-of-way of these highways with adjustments as necessary to eliminate conflicts with an active project.

New utility facilities along these routes will require approval by the State Utilities Engineer. Wherever practical, all new installations shall be located off the right-of-way or beyond the limit of access.

**2.5.B.2.c. Crossing of Highways with Access Control** - The District Engineer will review applications for the installation of utilities across limited access highways and forward to the State Utilities Engineer for approval.

**2.5.C. Written Authorization Required** - Before installing or relocating any utility facilities which will occupy or encroach on the State Highway System, the Utility owner will be required to obtain written authorization from the Department. For all initial installations, a permit will be issued. Also, for relocation or adjustment of facilities for which a written permit has not previously been issued, a permit will be issued. Rules and requirements for issuing permits are contained in Chapter 3 of this Manual. For relocation or adjustment of utilities to accommodate active projects where the Utility is to be reimbursed by the Department, a permit and an agreement will be executed and will contain the necessary authorization for the installation. Procedures for adjustment and relocation to accommodate active projects are described in Chapter 4 of this Manual.

**2.5.D. Compliance with Department Policies, Standards, and Specifications** - The required policies, standards and specifications for utility accommodation contained in this Manual attempt to cover the large majority of situations which will occur. They are general in application, particularly with regard to permissible locations of facilities within the right-of-way. There may be instances where a proposed installation appears to meet the requirements of this Manual, but special circumstances or other regulations may make the installation inappropriate. Each request for encroachment will be reviewed by the Department on its own merit with regard to its impact on safety, visual quality of the highway and the cost or difficulty of highway and utility construction and maintenance. See Tables 3-1 and 3-2 in Section 3.2.C of this Manual for the review process. The decision of the respective reviewer shall be final except for administrative appeal to the State Utilities Engineer. Any appeal shall require a formal written request providing detailed explanations and supporting documentation as to the reason why the decision should be reconsidered by the Department.

- 2.5.E. Compliance with Federal Laws and Regulations** - Requirements for the relocation and adjustment of utility facilities and for accommodating utility facilities on right-of-way are prescribed in the United States Code (USC) and Code of Federal Regulations (CFR), Title 23, Chapter I, Subchapter G, Part 645, Subparts A and B, (cited hereafter as 23 CFR 645). It is the policy of the Department to require full compliance with 23 CFR 645 and this Manual for all installations on right-of-way. Where laws, regulations, policies, procedures, provisions or standards conflict between the USC and 23 CFR 645 and this Manual, the more restrictive shall apply.
- 2.5.F. Utility Driveways** - The installation of utility driveways are generally needed for access to sites containing utility facilities such as power substations, water tanks, telephone service sites, and others. The Utility should apply for a driveway access permit for new utility facilities prior to purchase of an easement or property. The Department may approve utility driveway access by written permit under the *Regulations for Driveway and Encroachment Control*, current edition.
- 2.5.G. Private Lines** - Typically, private lines serve only the owner (e.g., farmer's waterline or an industrial plant's waste line, etc.) and not the general public. Private lines may cross the right-of-way by conforming to all other applicable requirements contained in this Manual. Longitudinal installations of private lines are not permitted. Exceptions may be granted by the State Utilities Engineer where a public interest can be demonstrated.
- 2.5.H. Service Lines** - Because it is in the interest of both the customer and Utility to have these connections, service lines are permitted on right-of-way as close to perpendicular as possible with the transmission facility with the exception that metering devices, vaults or pressure reducing mechanisms shall be located off the right-of-way. Any longitudinal installations of service lines shall be reviewed by the District Utilities Engineer on a case-by-case basis. This does not apply to installations serving a highway purpose. See Section 5.2.B.2 for control of cover.
- 2.5.I. Abandoned Facilities** - The Utility shall notify the Department in writing of the intention to abandon its facilities in place. Such abandoned installations within the right-of-way shall remain the responsibility of the Utility. The Department may give reasonable notice to require the removal of abandoned utility facilities and restoration of the right-of-way, or the filling of any such facility by an approved method, when necessary to avoid interference with the

operation, maintenance or reconstruction of the highway. Any utility facility that the Utility requests to abandon shall conform to the following:

1. All underground non-metallic utility facilities to be abandoned shall be locatable using a generally accepted electro-magnetic locating method to enable pipe and cable locates.
2. Any underground utility facility, approved or elected to be abandoned in place, larger than 2 inches up to 6 inches, inside diameter, shall be plugged at all open ends of the abandoned facilities. All facilities with an inside diameter larger than 6 inches shall be grout filled 100%. A request for an exception to this policy may be made to the State Utilities Engineer on a case by case basis when proven that no detriment will come to the roadbed by doing so.

**2.5.I.1. Hazardous Facilities to be Abandoned** - Whenever an existing utility facility contains a hazardous material and such facility exists in the public rights of way of any highway, road, or street, and the Utility determines that such facilities will no longer be utilized, the Utility that owns and operates the utility facility shall submit, for the State Utilities Office's review, the Request For Retention Of Abandoned Facilities Containing Hazardous Materials form (see GDOT's Utilities webpages) along with a permit through GUPS to the Department. Upon request for abandonment, the Utility shall have the discretion to:

- a. Remove and dispose of the asbestos pipe in accordance with federal laws and regulations;
- b. Leave the asbestos pipe in place and fill it with grout or other similar substance designed to harden within the pipe; or
- c. Allow the pipe to remain undisturbed in the ground and take no further action.

At the request of the Department or Utility, any hazardous material left in the right of way as authorized by the approval of the permit and accompanying Request for Retention of Abandoned Facilities Containing Hazardous Materials form shall be marked as to be locatable. The approved permit and form will indicate how the abandoned facility will be located. The Utility shall not relinquish the ownership of said facility as stated in OCGA Section 25-9 and Section 32-6-174; it shall be deemed abandoned and out of service.

If the Utility selects either item (b) or (c) above as part of a new utility installation request and said abandoned facility is later determined, at any time in the future, to be part of a highway improvement or project that the Department is undertaking or plans to undertake, or is in conflict with any other operation or activity upon said rights of way, by either the Department or others, then said facility shall be removed by the Utility in accordance with federal laws and regulations. Any costs, claims, or other liability associated with the owner's decision pursuant to this section shall be borne by said Utility.

- 2.5.J. Public Telephone** - The installation of telephones for the safety and convenience of the highway traveler may be permitted on the right-of-way, including rest areas of the Interstate System. The Department may approve telephone installations by written temporary permits under the provisions in Section 3.1.A.3 of this Manual. Permissible locations and standards for installation of telephones are included in Chapter 5 of this Manual.

## **2.6 INSTALLATIONS TO SERVE A HIGHWAY PURPOSE**

The policies, rules and standards of the Department, as described herein, regarding other types of utility installations, will also apply to installations requested by the Department to service highway facilities. The use and occupancy agreement may be a permit, if the entire cost of the installation is to be borne by the Utility, or an agreement, if the Department is to participate in the cost of the installation.

## **2.7 UTILITY OPERATION AND MAINTENANCE ACTIVITIES**

- 2.7.A. Authorization for Work on Right-of-Way** - The use and occupancy agreement required by Section 2.5.C (above) shall include the necessary authority for the continued operation and maintenance activities of the utility facility after installation. However, see Sections 3.7.E and 3.8 of this Manual for certain activities which do not require written authorization but require advance notice to the Department prior to beginning any work.

## **2.8 POLICY ON RELOCATION**

**2.8.A. Authority to Order Removal and Relocation** - Under the provisions of the O.C.G.A. § 32-6-171, the Department reserves the right to require the Utility to remove, repair, adjust or relocate any utility facilities installed within the right-of-way of a road which the Department has undertaken to improve, or intends to improve when, in the opinion of the Department, the facility constitutes an obstruction or interference with the use or safe operation of such road by the traveling public or will interfere with such construction or maintenance. All Utilities utilizing the right-of-way shall follow the Department's relocation procedures, as outlined in Chapter 4 of this Manual, so as not to adversely affect the Department's Construction Work Program or the Contractor's construction schedule for the project.

**2.8.A.1. Compensation for Relocation** - The removal, relocation, or adjustment of utilities shall be accomplished at the sole expense of the Utility except as it may qualify for reimbursement under the provisions of Chapter 4 of this Manual. The Department reserves the right to amend its policy on reimbursement as it may legally do so under the laws and Constitution of the State.

**2.8.A.2. Site for New Installation** - In the event it becomes necessary to require the Utility to relocate its facilities, and such facilities are still in use, and provided other suitable space is available, the Department may specify a new location in the right-of-way to which the facilities may be moved. If the right-of-way is insufficient to accommodate the relocated facilities, the facilities shall be required to be removed there from. See Chapter 4 of this Manual for provisions regarding acquisition of replacement right-of-way when required.

**2.8.B. Retention of Existing Underground Facilities On Highway Construction and Access Permits** - The Department's policy is that utility facilities will be relocated when they will be under the pavement on a project, including acceleration/deceleration lanes when required at side streets or commercial driveways. Exceptions may be granted by the State Utilities Engineer on a case by case basis. Retention requests, such as driveway permits, not in excess of 500 feet may be granted by the District Utilities Engineer when certain retention request criteria are met as identified in Section 5.3. All alternatives must be considered and proven impractical prior to requesting permission to retain facilities under the pavements on projects. Requests to retain facilities under pavement must be accompanied by detailed information, including, but not limited to, marked construction plans, cross

sections, drainage profiles, and, when required, a profile(s) of existing facilities to be retained. Actual depth checks will be required at potential conflict points with an elevation to the top and/or bottom of the facility that is tied to the project survey control provided in the plans. A completed Retention Request form (see GDOT's Utilities webpages) is necessary to objectively evaluate the request along with certain assurances regarding the maintenance, operations, and up-grading of the facilities involved. The request must be made promptly after the first plan submission stage of the Plan Development Process (PDP). A request that is made during the second plan submission stage may not be considered by the District Utilities Engineer.

**2.8.B.1. Review Factors for Retention Requests** - Factors that will be considered when reviewing retention requests are:

- a. The date of the installation of the facilities to be retained
- b. A listing of the length and sizes of the facilities to be retained by roadway stations
- c. The location and depth of the facilities to be retained as referenced to the existing edge of pavement
- d. Design characteristics of the facilities to be retained: type materials, operating pressure, capacity in use, available capacity, and structural considerations
- e. A summary of the operations history to include the following information as applicable: the most recent leaks survey, the number of service taps in the past three years, any maintenance repairs that have been required, the status of any protective systems, and the number of any unused ducts in a conduit system.
- f. An estimate of the remaining useful life of the facility
- g. A comparison of the cost involved for adjusting the facility versus relocating the facility.

**2.8.B.2. Assurances Required for Retention Requests** - The request for retention of the facilities must contain the following assurances:

- a. Where facilities are allowed to be retained, the Utility will make provisions for future service connections to be installed without cutting the pavement. Stubouts or other provisions shall be provided so that portions of the facilities can be abandoned when repairs are needed that would require cutting of the pavement.
- b. Retained facilities will be supplemented, as future needs increase, by installation of new facilities outside the pavement. The retained facilities will be abandoned, as economically



practical, to incorporate them into new plan.

- c. When manholes are retained, and if they are paved over, the Utility shall ensure that the manhole is suitable for traffic loads. If the conditions ever arises that the manhole needs to be accessed, the Utility shall follow Section 5.4 of this Manual.
- d. If manholes are retained under the pavement with no access tunnel, future access and blocking of the lanes will be done at off-peak traffic hours.
- e. All retained facilities shall have a thorough inspection, performed by the Utility, prior to the placement of the final paving surface to insure the integrity of the retained facility.

**2.8.B.3. Retention Requirements to Support Highway Loads** - An existing pipe or duct line too weak to support highway loads, if retained, shall be:

- a. Reinforced by jacket, wall or cap  
OR
- b. Sheltered by casing, half-pipe, box or arch (See Figure 6, below).

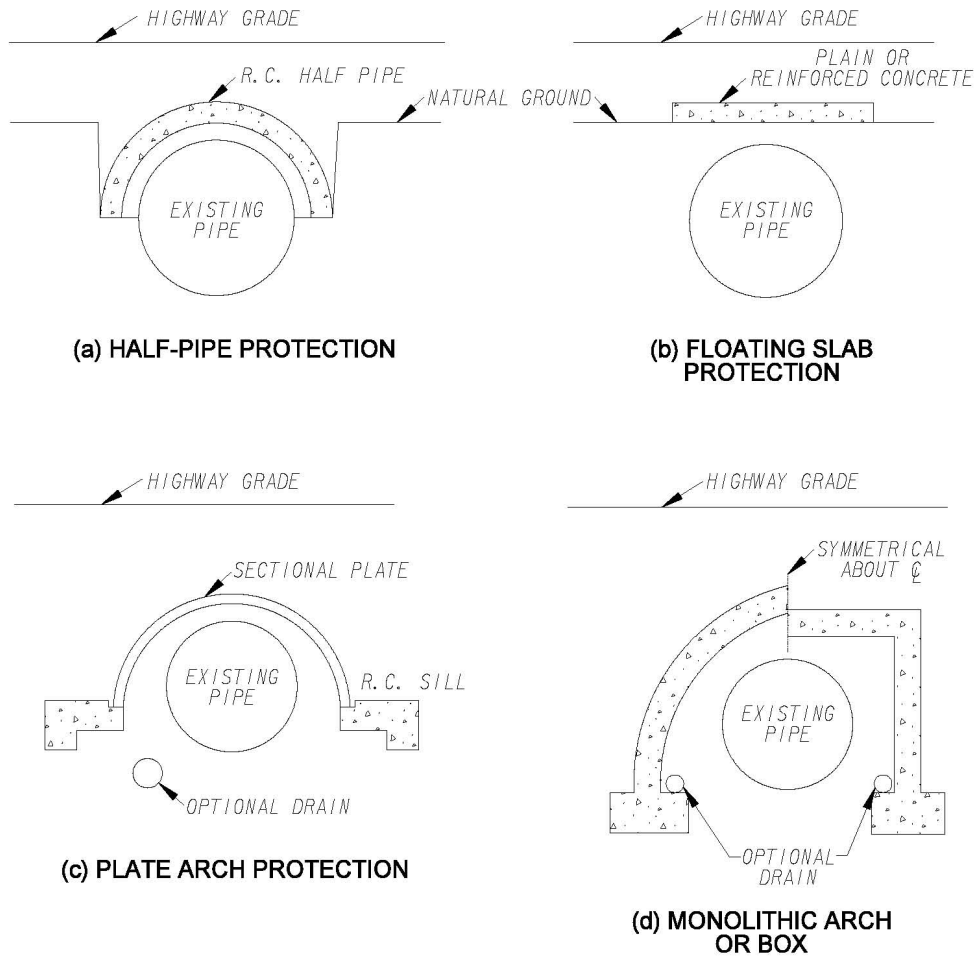

**EXISTING PIPELINE PROTECTION**

**FIGURE 6**

**2.8.C. Notifications, Failure to Begin or Complete Work** - Under the provisions of the O.C.G.A. § 32-6-171, the Department shall give to the Utility at least 60 days written notice directing it to begin the physical removal, relocation, or adjustment of such utility facility. The procedures for complying with the law and for the time frames allowed for each phase of the active project are set forth in Chapter 4 of this Manual. If the Utility does not thereafter begin removal, relocation, or adjustment within the time specified in the work plan, the Department may give the Utility a final notice directing that such removal, relocation, or adjustment shall commence not later than ten days from the receipt of such final notice. If such Utility does not, within ten days from receipt of such final notice, begin to remove, relocate, or adjust the facility or, having so begun removal, relocation, or adjustment, thereafter fails to complete the removal, relocation, or adjustment within the time specified in the work plan, the Department may exercise its right to obtain injunctive relief as provided for in O.C.G.A. § 32-6-175.

**2.8.C.1. Work Found Necessary after Project Letting Date** - In the event it becomes necessary to require the Utility to remove, relocate or adjust its facilities after the project Letting date, the utility shall provide a revised work plan within 30 calendar days after becoming aware of such additional work or upon receipt of the Department's written notification advising of such additional work. The Utility's work plan, whether new or revised shall be reviewed by the District Utilities Engineer to ensure compliance with the additional work.

**2.8.D. Failure to Comply** - Should the Utility fail to comply with any of the written notifications as outlined above, the Department may petition for an injunction to enforce the performance of the Utility's duty to not unduly delay a project or as may be such under O.C.G.A. § 32-6-175. Furthermore, the Utility may be responsible for and liable to the Department or its Contractors for documented damages resulting solely from failure on the part of the Utility to comply with the requirements of the submitted and approved work plan. If the Utility fails to provide a work plan or fails to complete the removal, relocation, or adjustment of its facilities in accordance with the work plan approved by the Department, then the Utility may be liable to the Contractor for delay costs incurred by the Contractor and approved by the Department which are caused by, or which grow out of, the failure of the Utility to carry out and complete its work in accordance with the approved work plan or revised work plan submitted.

Upon notification in writing by the Department or its Contractors that the Utility is liable for damages or delay costs, the Utility shall have 45 days from receipt of such letter to either pay the amount of the damages or delay costs to

the Department or its Contractors or to request mediation. (See Section 2.8.D of this Manual and the Rules of the State Department of Transportation - Board Rule 672-19.)

**2.8.D.1. Mediation** - The Department's utility relocation procedures set forth in Chapter 4 of this Manual and as promulgated in the GDOT Board Rule 672-19 include provision/s for the establishment of mediation boards to hear and decide disputes that may arise between the Department and the Utility concerning:

- a. A work plan or revised work plan that has been submitted by the Utility but not approved by the Department
- b. A Contractor's claim for delay costs or other damages related to the Utility's removal, relocation, or adjustment of its facilities  
AND
- c. Any other matters related to the authority of the Department to order the removal and relocation of utility facilities occupying the public road system to accommodate a Department's project construction.

**2.8.D.2. Removal by Department** - If the Utility abandons the work or the project or is no longer able to perform its removal, relocation, or adjustment work, the Department may remove or relocate the same with its forces or by employing or contracting for the necessary engineering, labor, equipment, tools, supervision, or other necessary services or materials and whatever else is necessary to accomplish the removal, relocation and adjustment.

**2.8.D.3. Reimbursement by Utility** - For work covered under Section 2.8.D (see above), the Department may then submit a bill for the full amount of the cost of removal, relocation, and adjustment to the Utility, and the amount shall become due immediately, or within such time as may be agreed upon between the Utility and the Department. In the event the Utility does not make payment or arrange to make payment within 60 days after receipt of a bill from the Department, the Department shall certify the amount for collection to the Attorney General.

## **2.9 POLICY ON TRAFFIC PROTECTION**

**2.9.A. Traffic Control** - The primary function of all temporary traffic control is to provide for the safe and efficient movement of vehicles, bicyclists, and pedestrians through or around temporary traffic control zones while reasonably protecting workers and equipment. A concurrent objective of the temporary traffic control is the efficient construction and maintenance of the highway and utilities.

**2.9.A.1. General** - As a minimum, the Utility shall comply with the *Manual on Uniform Traffic Control Devices* (MUTCD), current edition, for all utility work - whether or not written authorization is required. Copies of the current MUTCD may be obtained from the FHWA's website.

The safe passage of vehicular traffic, bicyclists, and pedestrians through and around a temporary traffic control work zone, while minimizing confusion and disruption to traffic flow, shall have priority over all other Utility activities. During the initial installation or construction of the facilities authorized by a permit, or during any future repair, removal, or relocation thereof, or during any miscellaneous operations and maintenance activities, the Utility shall, at all times, install, maintain, and remove all certified flaggers, signs, warning lights, channelization devices, and other safety devices as described in the MUTCD and the temporary traffic control plan. All temporary traffic control devices shall be removed from the Department's right-of-way as soon as practical when they are no longer needed. When work is suspended for short periods of time, temporary traffic control devices that are no longer applicable shall be removed or covered.

The Department reserves the right to require additional certified flaggers, signs, warning lights, channelization devices, and other safety devices as may be necessary to properly protect, warn, and safeguard the traveling public. Continued failure of the Utility to comply with the requirements of this or any other related section will result in the Department issuing a written order to stop work (i.e. Stop Work Order). Upon issuance of a Stop Work Order, all Utility work on the right-of-way will be suspended, except erosion control and traffic control, until corrective actions or deficiencies are addressed, and the Department issues a written resume work order.

In addition to this section, procedures and requirements for traffic control associated with a permit are contained in Chapter 3 and with

highway construction are contained in Chapter 4. Safety and convenience of traffic requirements are described in Chapter 5.

**2.9.A.2. Flagger** - All flaggers doing any flagging on the State Highway System must have received training and a certificate upon completion of the training. This includes all work, whether by contract or by permit, such as roadway construction, utility accommodations, etc. All costs for providing certified flaggers will be borne by the contractor, utility company, or any other entity granted permission to encroach upon right of way. Flaggers shall have their certification with them at all times when flagging, and may be subject to inspection.

Failure to provide certified flaggers as required above shall be reason for suspending work regarding the flagger(s) until a certified flagger can be provided. Flagger training and certification can be obtained through training organizations that provide certified American Traffic Safety Services Association (ATSSA) or National Safety Council (NSC) programs, or from ATSSA or NSC themselves.

**2.9.B. Restriction Against Interference with Traffic** - The Utility shall so conduct their operations that there will be a minimum of confusion with or disruption of traffic upon and along the highway. This applies to both the initial installation and the continuing maintenance and operation of utility facilities. On heavily traveled highways, construction or non-emergency maintenance operations interfering with traffic shall not be allowed during periods of peak traffic flow. All work shall be planned so that closure of intersecting streets, road approaches, or other access points is held to a minimum. It shall be the responsibility of the Utility to notify property owners when private driveways are to be affected and to provide temporary measures to maintain access during construction.

Except in emergencies, there shall be no interference with or interruption of traffic upon and along the highway until a temporary traffic control plan has been addressed in accordance with Section 3.7 of this Manual and other related sections. In emergencies, the Utility shall notify the Department's Area Engineer or Area Permit Inspector, as soon as practical, but no later than 2 hours after the onset of the emergency. If the emergency occurs during non-business hours, including weekends, the Utility shall contact the Department's emergency operations number at 511 or 1-877-694-2511 (Statewide). The Department reserves the right to prohibit any work which may interfere with traffic movement during times of peak traffic flow.

**2.9.C. Restrictions on Access** - It is expressly provided that, with respect to any limited access highway, the Utility, except as hereinafter provided, shall not have or gain direct access, either ingress or egress, from the main traveled way of said highway or its on or off ramps to any of the facilities authorized by the permit, and that access to said facilities from the main traveled way, or on or off ramps of said highway, is absolutely prohibited, either by vehicle or by foot. However, upon notice to the Department's Area Engineer or his representative that the construction of the authorized facilities pursuant to the permit is to be undertaken, or that an emergency exists and repairs are needed for the immediate protection of property and persons or prevention of injury, the Department may approve direct access for ingress and egress to said authorized facilities from said on and off ramps or main traveled ways, except that no vehicular traffic movement shall be allowed which would cross traffic or be contrary to normal traffic movement. Such permission will only be granted during the actual time of the construction of the authorized facilities or of the emergency, and the Utility agrees to take every precaution during such periods to safeguard the highway users. It is understood by the Utility that any violation of the above regulations governing limited access highways shall result in a cancellation of access privileges herein contained.

## **2.10 UNDERGROUNDING OF POLE LINES**

Typically, the Department does not require the undergrounding of pole-lines. However, the Department may participate, allow, or require undergrounding when it can be shown that it is in the public interest.

A public interest determination might be justified from the standpoint of highway safety, aesthetics, economic development, community health, reduced network outages, scenic, environmental, historical, and other such concerns.

**2.10.A. Highway Safety Determination** - The Department may require or participate in undergrounding existing or proposed overhead utilities to improve crash statistics. The determination on cost and participation by the department may be related to the anticipated reduction in crash statistics and the roadway/accident ranking. However, the Department's share shall not exceed 50% of the total cost. This work shall not include retrofitting existing service/house connections, since this work is more problematic, and, therefore, aboveground facilities may exist and remain on private property after the improvement project.

**2.10.B. Aesthetics Determination** - Typically, the Local political subdivision by law or ordinance may require existing or proposed overhead utilities to be installed underground for economic development or possibly for community health reasons. This work may include retrofitting existing service line connections and these costs can vary depending upon terrain and whether the community is an urban or rural area. Furthermore, Utilities have documented that it's often difficult to locate problems in buried lines and they require special equipment and crews to locate faults, increasing their annual operation cost. Therefore, these costs shall be addressed by the Local political subdivision and included in the written request. When all parties affected under this determination agree, then the Department will provide oversight or assistance as needed for the Local political subdivision and utility costs. The Agreement (per Section 4.2 of this Manual) will be prepared between the Local political subdivision and the Utility indicating the funding responsibilities of each of the parties.

**2.10.C. Reduced Network Outages Determination** - The Department may allow undergrounding of existing or proposed overhead utilities when the Utility agrees in writing to bear 100% of the cost. Also, approval for undergrounding may be included in this determination if the consideration of obtaining approval for installations along certain scenic enhancement areas (per Section 5.1.G of this Manual) or for other such concerns.

If it is determined that the reason for undergrounding a pole-line is either highway safety or aesthetics, no future overhead pole-lines will be permitted along the section of highway where the undergrounding is to be provided.

**2.11 WORK TIME RESTRICTIONS OR MORATORIUMS**

The Department reserves the right to place time restrictions or moratoriums on all utility work covered under a permit when, in the opinion of the Department, the continuance of the Work would seriously hinder traffic flow, be needlessly disruptive, or would unnecessarily inconvenience the traveling public. The Utility shall suspend and/or reschedule any work when the Department deems that conditions are unfavorable for continuing the work. Advance notification requirements to the Utility to suspend work will be according to the events and the time restrictions outlined below:

Incident management / emergencies	No advanced notice required
Threatening/Inclement weather	24 hours



Holidays; sporting events; unfavorable conditions

3 calendar days

The Department will not consider any request for compensation for loss of productivity, rescheduling of crews, rental of equipment, or delays to the Utility’s schedule.

## **2.12 CONTROL OF SOIL, EROSION, AND SEDIMENTATION**

The Utility is responsible for following and implementing the requirements of the laws regarding control of soil, erosion, and sedimentation. The Utility shall apply for and obtain all permits required to perform their work. On active construction projects, the Utility is responsible for permitting of all work not specifically covered by the Department’s plans and permits.

## **2.13 ENVIRONMENTALLY SENSITIVE AREAS (ESA)**

No work shall occur on known or apparent right-of-way sites designated as an ESA until the necessary Federal, State, and Local permit(s) are acquired by the Utility. The District Utilities Engineer is responsible for providing the most current version of the Department’s environmental “Green Sheet”. The earliest available version that will be provided to the Utilities shall be the Final Field Plan Review version. The District Utilities Engineer is responsible for providing the Utility the most current version prior to the Letting; as well as any updated versions as the active project progresses.

In cases where the Utility encounters an ESA that was not previously known prior to the issuance of a permit, the Utility shall immediately cease operations and contact the District Utilities Engineer. The District Utilities Engineer will contact the Department’s Office of Environmental Services to determine the disposition thereof. When directed by the District Utilities Engineer, the Utility shall resume operations in such a manner as to comply with the proper authorities’ requirements.

**This Page Intentionally Left Blank**

## **CHAPTER 3: RULES FOR ISSUING UTILITY PERMITS**

### **3.0 QUALIFICATIONS**

All Utilities shall meet and maintain the following qualifications in order to operate facilities on the State Highway System. The below information must be current and on file with the State Utilities Office. At a minimum, any changes must be updated on an annual basis. The Utility must:

- A. Satisfy the requirements of the Secretary of State of Georgia and the Georgia Public Service Commission (PSC) unless exempt and provide evidence of compliance.
- B. Maintain a permanent office, or have resources under contract, within the State of Georgia with sufficient staff who is available 7 days a week, 24 hours a day. Staff shall be authorized to repair, adjust or relocate company facility(ies) involved with any emergency situation; and to perform relocation work (maintenance and construction) necessitated by highway construction. The Utility shall provide contact information (address, contact name and telephone number) of company(ies) performing said work.
- C. Be a member of Georgia811 and participate in the One Call System.
- D. Provide proof of insurance or self-insurance. If deemed necessary, the Department may require a bond for permit work. See Section 3.5 of this Manual.
- E. Inform the Department, in detail, what types of services are being provided to the citizens of Georgia.
- F. Provide any other information deemed necessary by the Department.

### **3.1 REQUIREMENTS FOR PERMITS**

All Utilities shall be required to apply for and obtain written permission from the Department prior to using or occupying any part of the right-of-way. A permit will be required for the following, unless excluded under Section 3.8.B of this Manual:

- A. Any new utility facility or any changes to existing facilities
- B. “Special Case Utilities” (see Section 5.8 of this Manual) such as irrigation, drainage facilities not connected with highway drainage and clay pipeline facilities
- C. Installing facilities adjacent to the right-of-way so as to require trimming on the right-of-way
- D. Installing or maintaining facilities adjacent to the right-of-way so as to require

- operating or construction clearance within the right-of-way
- E. Excavating and boring within the roadbed structure
- F. Cutting of any paved surface.

A separate permit shall be required for each route number and each county where the installation is proposed.

See Section 3.9 of this Manual for emergency situations.

### 3.1.A. Types of Permits

**3.1.A.1. General Encroachment Permit** - The Department has adopted form DOT 8413A, a copy of which is available through the Georgia Utilities Permitting System (GUPS) as a general permit to be used for all types of utility installations including when a Utility has facilities within an active project.

**3.1.A.2. Blasting Permit** - The Department will not require a blasting permit while working on Department's right of way, but, when the use of explosives is necessary, the Contractor/Utility shall exercise the utmost care not to endanger life or property, and shall obey all State, Federal and other Governmental regulations applying to transportation, storage, use, and control of such explosives. The Contractor/Utility shall be completely responsible for any and all damage resulting from the transportation, storage, use, and control of explosives in the prosecution of the work by the Contractor/Utility, the Contractor's/Utility's agents, or employees; and shall hold the Department harmless from all claims of damages resulting in any manner therefrom.

The Contractor/Utility shall notify each public utility owner having structures or other installations, above or below ground, near the site of his intention to use explosives. Such notice shall be given sufficiently in advance to enable the utility owners to take such steps as they may deem necessary to protect their property from injury. Such notice shall not relieve the Contractor/Utility of responsibility for all damages resulting from his blasting operations.

The Contractor/Utility shall notify the Inspector/Area Engineer a minimum of five working days prior to use of explosives.

If the use of explosives is required in Railroad right-of-way, then see Section 7.1 of this manual.

**3.1.A.3. Public Telephone Permit** - The installation of public telephones inside buildings in rest areas will not require a separate permit. For telephone installations located along the roadside, GUPS will be used and will include a Special Provision requiring removal of the telephone and appurtenances within 10 days after notice from the Department of Transportation that the permit is rescinded. Application for a permit for telephone installation within the right-of-way shall be accompanied by a certification by the Utility that neither the Utility nor others will reimburse the adjacent property owner in any manner for his concurrence in the location of a telephone. Utility shall also certify that no person, persons, organization, etc., will be granted consideration of any type for the privilege of operating the telephone within the right-of-way, nor shall any person, persons, organizations, etc. outside the Utility's normal organization be granted a percentage of the revenue, a fixed fee or any compensation of any nature from the operation of the telephone authorized to operate within the right-of-way.

**3.1.A.4. Vegetation Management Permit** - See Chapter 6 of this Manual.

**3.1.B. Terms and Conditions of Permit** - The Utility, in accepting the permit, agrees to abide by its terms and conditions. The Utility's proposed installation must comply with this Manual, and any other requirements that the Department may stipulate. Special requirements are typically discussed with the Utility during the Department's review of the application. However, the Utility shall review the permit for any added requirements and, if not in agreement, may withdraw the permit application by written request prior to installing the facilities covered by the permit. The Utility, in accepting the permit, agrees to abide by the terms and conditions thereof. Failure to comply with terms of the permit during the installation, operation and maintenance of the utility facility may result in revocation of the permit and removal of the facility.

## **3.2 PERMIT APPLICATION AND APPROVAL PROCEDURE**

**3.2.A. Where to Apply** - Application for utility encroachment permits shall be made utilizing GUPS to the Department's District Utilities Engineer having supervisory responsibility for the area in which the facilities are to be installed.

**3.2.B. Authority to Approve** - The District Engineer shall have authority to approve applications involving utility encroachments including all applicable permit forms and provisions; except that no approval shall be given until all reviews and concurrences by other offices within the Department or by other agencies has been obtained.

It shall be the responsibility of the District Engineer to obtain all necessary reviews and concurrences. All applications which are referred to the State Utilities Engineer will be returned to the District Engineer for final action after the necessary reviews have been completed.

**3.2.B.1. Structures** - Permit applications for any installation which will involve excavation within 10 feet of structures or walls or attachments to bridges shall be submitted to the appropriate District Utilities Office for review and recommendation. If recommended, the permit must have the approval of the State Bridge Office. Upon approval of the State Bridge Office, the permit will be forwarded to the District Engineer or State Utilities Engineer for final approval. When attachments are to be made to bridges over a railroad, the Utility shall obtain written concurrence from the Railroad before the Department will release an approved permit. See Section 5.7.C for additional information concerning controls for utilities near highway structures.

**3.2.B.2. Blasting** - Applications in GUPS for utility encroachment permits shall require a yes or no answer only to indicate whether or not blasting is required for the requested installation; otherwise, reference Sections 3.1.A.2 and 7.1.B concerning blasting requirements.

**3.2.B.3. Active Projects** - Permits will not be approved until adequately coordinated with the project plans and contract.

**3.2.B.4. Interstates** - Any request for encroachment on Interstate highway involving an exception to the State's policy and standards, as described herein, shall require the approval of the Commissioner. The Department, when required, will request approval of the FHWA.

**3.2.B.5. Utility Driveways** - A GUPS utility encroachment permit does not grant driveway access approval. Any request for driveway access to a Utilities facility, whether located on or off of the right-of-way, will require permission (driveway permit) from the Department's Traffic Operations Office. It is recommended that the Utility coordinate

with the Department before they purchase a site or obtain an easement for such facilities as power substations, water tanks, sewer lift stations, telephone service cabinets, gas regulator sites, or telecommunication service.

**3.2.C. Approval of Other Agencies** - Applications for utility encroachments on State-owned property under control of the Department of Transportation should be made to the Department's District Office thru GUPS in the same manner as for encroachments on right-of-way. After review in the District, the application will be forwarded to the State Utilities Engineer for coordination with the other State Departments or agencies involved.

See Tables 3-1 and 3-2, following this Section, for a list of required reviews, concurrences and approvals for longitudinal and crossing installation types, respectively:

Table 3-1 Longitudinal Installation Types	Field Districts	Office of Utilities	Office of Traffic Operations	Office of Maintenance	Office of Bridge Design	Office of Materials & Research	Office of Intermodal	Railroad Owner	Area office	Division of Permits & Operations	Chief Engineer	Commissioner	FHWA
Interstate & Limited Access Highways	●	●								●	●	●	●
Non-Interstate & Non-Limited Access Highways (In Roadbed)	●	●											
Bridge Attachments	●	●			●								
Railroad Bridge Attachments	●	●			●			●					
Transmission facilities larger than 115 KV	●	●								●			
Cuts in pavement	●	●											
Public Telephones	●	●	●										
Detailed Traffic Control Plan	●		●										
Landscape Mitigation Plan	●	●		●									
Vegetation Management Pesticides	●	●		●									
On active project (Subsurface Utility engineering)	●	●							●				
GDOT Railroads	●	●					●						
Rule 672-11 Fees	●	●											
Clay pipelines and Irrigation lines	●	●											
Private Lines	●	●											
Utility tunnel	●	●			●	●							
New poles within high pole accident area	●	●											
Retain under pavement	●	●											
Less than min. cover	●	●											



Table 3-2 Crossing Installation Types	Field Districts	Office of Utilities	Office of Traffic Operations	Office of Maintenance	Office of Bridge Design	Office of Materials & Research	Office of Intermodal	Railroad Owner	Area office	Division of Permits & Operations	Chief Engineer	Commissioner	FHWA
Interstate & Limited Access Highways	●	●											
Non-Interstate & Non-Limited Access Highways	●												
Bridge Attachments	●	●			●								
Railroad Bridge Attachments	●	●			●			●					
Transmission facilities larger than 115 KV	●	●								●			
Cuts in pavement	●	●											
On active project (Subsurface Utility engineering)	●	●							●				
Detailed Traffic Control Plan	●		●										
Landscape Mitigation Plan	●	●		●									
Vegetation Management Pesticides	●	●		●									
New poles within high pole accident area	●	●											
GDOT Railroads	●	●					●						
Less than min. cover	●	●											
Clay pipelines and Irrigation lines	●	●											
Private Lines	●	●											
Rule 672-13 Fees	●	●										●	
Utility tunnel	●	●			●	●							
Less than min. cover	●	●											

Tables 3-1 & 3-2: The tables have been prepared to reflect the typical permit review process for the Utilities’ planning purposes. The Department reserves the right to change or modify the process as needed.

### **3.3 ALLOCATION OF COSTS**

**3.3.A. Permit Fee** - There shall be no charge for the issuance of the permit except as required by the Department's Board Rule 672-11 promulgated in accordance with O.C.G.A. § 32-6-174.

**3.3.B. Installation Costs** - The entire cost of installing, maintaining, repairing, operating, or using the pole-line, buried cable, pipeline, or miscellaneous utility facility, performing miscellaneous operations and any other expense whatsoever incidental to the facilities or operations authorized by the permit, shall be paid by the Utility, unless provided for within reimbursable Utility Agreement as indicated in Chapter 4 of this Manual.

**3.3.C. Reimbursement of Department Expense** - If the Department is required to incur additional or unusual expense to insure compliance with the terms of the permit due to extraordinary inspection requirements or the Utility's inadequate control procedures, the Utility shall reimburse the Department for such additional cost of inspection and any repairs the Department must make to the highway. Said reimbursement shall be due whether the additional or unusual expense is incurred through services by Department personnel or by the Department's contractor.

Inspection and testing: The necessity of inspection and testing of permitted facilities will be determined by the Department acting within its sole discretion. The Department shall supervise all inspection and testing as deemed necessary by the Department. The Department may require the Utility to hire an engineering firm licensed in Georgia and listed on the Department's Prequalified List to perform this work at the Utility's expense. All costs incurred by the State necessary for these functions will be paid for by the Utility. Operations shall be subject to State inspection at all times.

The Utility shall reimburse the Department for direct costs associated with repairs to restore the right-of-way where right-of-way has been damaged as a result failure of the Utility, after due notice, to properly install, operate, or maintain its facility. The costs will be based on the actual cost incurred as supported by the Department's records. The Utility shall make the reimbursement within 60 days after receiving a statement from the Department.

- 3.3.D. Materials within the Right-of-Way** - The Utility, upon notification in writing by the Department’s Engineer, shall replace or pay for any materials removed from the right-of-way or destroyed as a result of the Utility’s operations authorized by the permit. The Utility shall make the reimbursement within 60 days after receiving a statement from the Department.

### **3.4 LIABILITY AND CONTROL**

- 3.4.A. Damages Resulting from Installation** - The Utility shall indemnify and hold harmless the State, the Department of Transportation, the members thereof, and all officers, employees, or agents of the State or the Department of Transportation, or any political subdivision thereof, against any and all damages, claims, demands, actions, causes of action, costs, and expenses of whatsoever nature which may result from any injury to, or the death of, any persons or from the loss of, or damages to, property of any kind or nature, including the highway and highway facilities or structures, property, or equipment used or owned by the State or the Department of Transportation, and facilities, which now or may hereafter, occupy the right-of-way of the said highway, when such injury, death, loss, or damages arise out of the construction, installation, maintenance, repair, removal, relocation, operation, or use of the pole-line, buried cable, pipeline, or miscellaneous utility facility covered by the permit, or out of miscellaneous operations authorized by the permit. Any supervision or control exercised by the Department shall in no way relieve the Utility of any duty or responsibility to the general public, nor shall such supervision or control relieve the Utility from the requirement of this Section of this Manual.

This indemnification extends to the successors and assigns of the Utility. This indemnification obligation survives the termination or revocation of the permit and the dissolution or, to the extent allowed by law, the bankruptcy of the Utility. If and to the extent such damage or loss (including costs and expenses) as covered by this indemnification is paid by the State Tort Claims Trust Fund, the State Authority Liability Trust Fund, the State Employee Broad Form Liability Fund, the State Insurance and Hazard Reserve Fund, and other self-insured funds (all such funds hereinafter collectively referred to as the “Funds”) established and maintained by the State of Georgia Department of Administrative Services Risk Management Division, the Utility shall reimburse the Funds for such monies paid out by the Funds.

This indemnification applies where the Indemnitees are partially responsible for the situation giving rise to the claim, provided, however, that this

indemnification does not apply to the extent of the sole negligence of the Indemnitees.

This indemnification does not extend beyond the scope of the permit and the uses or work undertaken there under.

- 3.4.B. Injury or Damage to Utilities** - The State, the Department of Transportation, the members thereof, and all officers, employees, or agents of the State or the Department of Transportation, shall not be held responsible or liable for injury or damage that may occur to facilities covered by the permit, or to any connection or connections thereto, by reason of highway maintenance and construction activities, as a result of the work performed by the Department's employees.
- 3.4.C. Right-of-Way Restoration and Liability** - The area disturbed by Utility construction or maintenance, shall be kept to a minimum. The Utility shall restore all right-of-way to a condition equal to or better than the existing condition. Restoration methods shall conform to the Department's current Standard and Supplemental Specifications and/or Special Provisions, and Construction Standards and Details. Restoration work must be approved by the Department. If necessary, unsatisfactory restoration work will be corrected by the Utility or the Department, and, if performed by the Department, the cost billed to the Utility Company.
- 3.4.D. Protection of Public** - The Utility shall have sole responsibility for the adequacy and safety of the design and engineering of its facilities, in performing the operations authorized by the permit; in addition to any methods which the Department may require in order to properly protect the public from injury and the highway from damage.
- 3.4.E. Inspection of Facilities** - The Department reserves the right to inspect the facilities during such periods as the Inspector deems necessary to check compliance with the permit. The Utility shall facilitate access to the facility for the inspection in accordance with the Department's schedule. At such time the Utility shall make known to the Department any reasonable security measures. The Department's agents, employees, and independent contractors may at any time, upon 24 hours advanced notice, and during regular business hours, conduct such inspections and physical engineering studies as the Department deems appropriate upon the facilities of the Utility located in, on, along, over, or under any part of the State Highway System or any public road

project within the State of Georgia (the “Property”), including, but not limited to, facilities located within manholes, vaults, valves, etc. The Department and the Department’s agents, employees, and independent contractors shall have the right to come onto the Property for the purposes of surveying the Property and conducting such inspections and studies as the Department desires, provided that any such inspections and studies do not change in any material manner the current physical condition of the Property. Should the physical condition of the Property be affected by said inspections and studies, the Department will return the Property to its original condition at its own expense.

- 3.4.F. Work by Utility Contractors** - When the Utility shall contract for any work to be performed on the right-of-way under authority of the permit, the Utility shall ensure its Utility’s contractor shall agree in writing prior to beginning work, that such work will be performed in accordance with the Department's current *Utility Accommodation Policy and Standards Manual*, current Standard and Supplemental Specifications and/or Special Provisions, and Construction Standards and Details, and be subject to inspection by the Department to ensure compliance. The written contract/agreement shall further provide that the Department shall be held harmless for any extra expense or damages to the Utility’s contractor as a result of any action the Department may require to correct all deviations from the said Policies, Standards, and Specifications. This agreement may be made a part of continuing contracts or bid contract documents. If not included in the contract, a Special Assurances form shall be completed prior to work beginning and submitted to the Department’s District Utilities Engineer, Area Engineer, or Inspector. When any Utility’s contractor develops a history of poor performance, the Department reserves the right to require the Utility’s contractor to furnish a performance bond, letter of credit, or letter of escrow in an amount specified by the District Engineer in accordance with Section 3.5.F of this Manual. Upon continued refusal of the Utility’s contractor to comply with Department policies, standards, and specifications, the Department may ban said Utility’s contractor from working within the right-of-way.
- 3.4.G. Final Permit Authority** - The decision of the Department shall be final and conclusive with respect to any of the conditions, terms, stipulations, and provisions of the permit. This may not foreclose the Utility's right of appeal for active projects as provided for in O.C.G.A. § 32-6-171.
- 3.4.H. Utility Stop Work Order** - Situations may occur during permit performance that cause the Department to order a suspension of work or a

work stoppage. The Department is authorized to issue a Utility Stop Work Order form 413SW whenever a violation of the permit is occurring or imminent danger exists. A Stop Work Order shall be in writing and shall be given to the Utility involved, the Utility's agent, or to the Utility's contractor engaged in the activity suspected of the violation.

The Utility receiving a Stop Work Order will be required to cease all utility/construction activities on the right-of-way. The Utility shall remove all equipment and materials from the site and only perform work which shall prevent damage or deterioration of the site or for the safety of the public. This Stop Work Order will be in effect until the Department confirms that corrective measures or permit compliance has been satisfactorily addressed by the Area Engineer or Permit Inspector. Promptly after issuing the Stop Work Order, the Permit Inspector should forward a copy to and discuss the Stop Work Order with the District Utilities Engineer. Failure by the Utility to address the violation in a timely manner can result in permit revocation and jeopardize any future permit applications.

**3.4.H.1. When to Use a Stop Work Order** - One of the following conditions must be present before a Stop Work Order is issued:

- Inadequate erosion control
- Inadequate traffic control
- Utility damages others facilities
- Utility damages the Department's right-of-way
- The Department views it as an Imminent Danger situation
- Utility is not installing their facilities in accordance with the approved permit
- The Department has no other immediate option to get the situation corrected.

There shall be no retributive actions for invoking a legitimate stop-work order, even if it is determined later that the actual hazard severity or potential was insufficient to justify the action. It is important that the stop work process is respected by all, and that it is not used in a deliberately disruptive way.

**3.4.H.2. Return to Work** - The District Utilities Engineer shall determine if and when the Utility may resume activities after a stop work action. This decision shall be based on the Permit Inspector's investigation and any other pertinent information. A Utility Return to Work Order form 413RW must be issued in written form including any

preconditions or procedural modifications. The Utility once again agrees to comply with and be bound by the Department's *Utility Accommodation Policy and Standards* on file in the State Utilities Office of the Department of Transportation. The Utility shall comply with all General Provisions and Special Provisions shown on the original permit or revised permit, and any Special Conditions listed on the return to work order during the installation, operation, and maintenance of said Utility facilities within the right-of-way.

### **3.5 INSURANCE AND BOND**

**3.5.A. Requirement for Insurance** - The Utility or Utility's contractor shall obtain and carry, for the period of time required for the complete installation of the facilities authorized by the permit, including the repair and restoration of the highway facilities, and also during such future periods of time when operations are performed involving the repair, relocation, or removal of said facilities authorized by the permit, a liability and property damage insurance policy, or policies, holding the Department harmless from any damages arising out of operations performed or authorized by the permit. The Utility shall procure the insurance coverages identified below at the Utility's own expense and shall furnish the Department with an insurance certificate or a certificate from the Utility's self-insurance program. The insurance certificate must provide the following:

1. Name and address of authorized agent
2. Name and address of insured
3. Name of insurance company(ies)
4. Description of policies
5. Policy Number(s)
6. Policy Period(s)
7. Limits of liability
8. Project Number and Name or Permit Number
9. Signature of authorized agent
10. Telephone number of authorized agent
11. Mandatory 30 days notice of cancellation/non-renewal.

**3.5.B. Policy Provisions** - Each of the insurance coverages required below shall be (1) issued by a company licensed by the Insurance Commissioner to

transact the business of insurance in the State of Georgia for the applicable line of insurance, and (2) an insurer (or, for qualified self-insureds or group self-insureds, a specific excess insurer providing statutory limits) with a Best Policyholders Rating of "A-" or better and with a financial size rating of Class V or larger. Each such policy shall contain the following provisions:

1. The insurance company agrees that the policy shall not be canceled, changed, allowed to lapse, or allowed to expire until 30 days after the Department has received written notice thereof as evidenced by return receipt of registered letter or until such time as other insurance coverage providing protection equal to protection called for in this contract shall have been received, accepted, and acknowledged by the Department.
2. The policy shall not be subject to invalidation as to any insured by reason of any act or omission of another insured or any of its officers, employees, agents, or other representatives ("Separation of Insureds").
3. The Utility shall notify each Insurer that the statutory requirement that the Attorney General of Georgia shall represent and defend the Indemnitees remains in full force and effect and is not waived by any policy of insurance. The Attorney General of Georgia shall represent and defend the Indemnitees. In the event of litigation, any settlement on behalf of the Indemnitees must be expressly approved by the Attorney General. The Utility and its insurance carrier may retain, but are not obligated to retain, counsel to assist with the defense of the Indemnitees, in which case there will be mutual cooperation between the Attorney General and such counsel.
4. Self-insured retention, except for qualified self-insurers or group self-insurers, in any policy shall not exceed \$100,000.00.

**3.5.C. Insurance Coverages** - The Utility shall purchase and have the authorized agent state on the insurance certificate that the following types of insurance coverages, not inconsistent with the policies and requirements of O.C.G.A. § 50-21-37, have been purchased by the Utility. The minimum required coverages and liability limits are as follows:

**3.5.C.1. Workers' Compensation** - The Utility agrees to provide Workers' Compensation coverage in accordance with the statutory limits as established by the General Assembly of the State of Georgia. A group-insurer must submit a certificate of authority from the Insurance Commissioner approving the group insurance plan. A self-insurer must submit a certificate from the Georgia State Board of Workers' Compensation stating the Utility qualifies to pay its own workers' compensation claims. The Utility shall require all contractors using the property or performing work under this



agreement to obtain an insurance certificate showing proof of Workers' Compensation and shall submit a certificate on the letterhead of the Utility in the following language prior to taking possession of the property: "This is to certify that all contractors performing work on this property are covered by their own worker's compensation insurance or are covered by the Utility's worker's compensation insurance."

**3.5.C.2. Employers' Liability Insurance** - The Utility shall also maintain Employers Liability Insurance Coverage with limits of at least (a) Bodily Injury by Accident - \$1,000,000 each accident; and, (b) Bodily Injury by Disease - \$1,000,000 each employee. The Utility shall require all contractors performing work under this agreement to obtain an insurance certificate showing proof of Employers Liability Insurance Coverage and shall submit a certificate on the letterhead of the Utility in the following language prior to taking possession of the property: "This is to certify that all contractors performing work on this property are covered by their own employers liability insurance or are covered by the general Utility's employers liability insurance."

**3.5.C.3. Commercial General Liability Insurance** - The Utility shall provide Commercial General Liability Insurance (1993 ISO Occurrence form or equivalent) which shall include, but need not be limited to, coverage for personal injury and advertising liability, and contractual liability. The Commercial General Liability Insurance shall provide at minimum the following limits:

<u>Coverage</u>	<u>Limit</u>
1. Personal Injury and Advertising	\$1,000,000 per Occurrence
2. Contractual	\$1,000,000 per Occurrence
3. General Aggregate	\$2,000,000

The policy or policies must be on an "occurrence" basis and must include separate aggregate limits for each permit.

**3.5.C.4. Commercial Umbrella Liability Insurance** - The Utility shall provide a Commercial Umbrella Liability Insurance Policy to provide excess coverage above the Commercial General Liability, the Workers' Compensation and Employers' Liability to satisfy the minimum limits set forth herein. The minimum amount of Umbrella limits required above shall be \$2,000,000.00 per Occurrence and \$4,000,000.00 Aggregate. The policy must be on an "occurrence" basis.

- 3.5.D. Termination of Obligation to Insure** - Unless otherwise expressly provided to the contrary, the obligation to insure, as provided herein, shall not terminate so long as the permit is in effect, or until the Utility shall have vacated the property, whichever is the later.
- 3.5.E. Failure of Insurers** - The Utility is responsible for any delay resulting from the failure of his insurance carriers to furnish proof of proper coverage in the prescribed form, or for the insolvency or financial failure of such insurance carriers.
- 3.5.F. Requirement for Performance Bond, Letter of Credit, or Letter of Escrow** - The requirement of bonding is an assignment of risk issue. It can create a lot of unnecessary and costly administrative work. Therefore, the position taken by the Department is no bond will be required unless there are unique circumstances, or when the installation of a Utility is being performed by or for an entity that is not registered with the Secretary of State as a business or contractor. A performance bond, letter of credit, or letter of escrow payable to the Department shall be required as a condition of the permit. When requested in writing by the Department or during the permitting process, the Utility or Utility's contractor shall furnish, for the period of time required for the complete installation of the facilities authorized by the permit, including the repair and restoration of the highway facilities, and also during such future periods of time when operations are performed involving the repair, relocation or removal of said facilities authorized by the permit. The amount of the performance bond, letter of credit, or letter of escrow shall be limited to an engineering estimate of potential infrastructure damages, restoration, or replacement, and any appurtenances, materials, or services necessary to conduct the work as specified in the Special Provisions of the permit. The performance bond, letter of credit, or letter of escrow shall be written by a Surety Company or Bank duly qualified and licensed to do business in the State of Georgia. No work shall be commenced under the permit until the said performance bond, letter of credit, or letter of escrow has been submitted to and approved by the Department.

### **3.6 INSTALLATION DETAILS**

**3.6.A. Plans to Accompany Permit** - The Utility shall submit via GUPS, the electronic permitting system, plan sheets which will be legible at either ledger size (11 inch x 17 inch) or letter size (8 ½ inch by 11 inch) with the permit application. The plans shall show in detail the location of the proposed facility or operations as described in the said permit application. The plans shall also show the size, material, pressure (design, normal, maximum), capacity, etc. of facilities to be installed; their relationship to highway features such as right-of-way lines, pavement type, pavement edge, structures, roadway drainage, etc., horizontal and vertical clearance to critical elements of the roadway, other existing Utilities, proposed test hole locations, and any other information necessary to evaluate the impact to the right-of-way and the safety of its users.

Permits showing relocations for Department projects or new Utility installations on active projects will include all the above items and shown on the project plans sheets, utility adjustment schedule, cost estimate (if relocated plan) and other items necessary. Special plan requirements may be requested by the District Utilities Engineer on any active project that is under construction. This requirement is additional to the above and may include, but is not limited to, voluntary conversion by the Utility to the metric system of measurement (if Department plans are in metric) and shall be shown on copies of project construction plans.

Permits requested within the limits of a Department Let, non-active project currently listed in the Department's Construction Work Program will require all items previously mentioned and a No-Cost letter stating that the utility facility will be relocated at no-cost to the Department if found to be in conflict once the project becomes active.

Proposed installations on the Interstate System shall be shown on copies of highway project construction plans. These plans must be updated by the Utility to show actual field conditions. If highway construction plans are not available, the Utility shall perform a detailed field review showing right-of-way, drainage, and other information necessary to determine the acceptability of the proposed work.

When attachment to a highway structure, bridge, culvert, wall, etc. is involved, the Utility shall include in the plans or drawings a complete description as to location, type, size, and details of the attachment method. In the case of attachments to bridges, the unit weights of the materials to be attached shall be provided. The application should also include detailed drawings of the bridge and the proposed attachment. As a minimum, these drawings should include a plan and elevation view along with sufficient sections to enable the State

Bridge Office to determine the relative position of the proposed attachments to all members of the bridge superstructure. For attaching utilities to existing bridges where no Department plans exist, provide a readable set of county plans, Corps of Engineers plans, or other design drawings. If no plans exist, submit detailed drawings showing sufficient details to adequately evaluate the permit application. Drawings shall contain a north arrow and clearly state on which side of the bridge the Utility is being proposed. Supply recent photographs showing the area of proposed Utility attachment to the bridge. Give descriptions of photographs with attention given to compass direction. Drawing on photographs for clarification is advisable.

Plans shall also show whether cathodic protection is to be provided and the proposed method for insulating bridge members from electrical currents.

When required by the District, soil borings or other soil investigations shall be made to determine the nature of the underlying material for underground installations. If borings have been taken prior to application for a work permit, a copy of the boring logs shall be submitted with the permit application. Any soil borings, or additional borings, that may be required shall be performed at the sole expense of the Utility.

The Department's policy is to remove roadside obstacles where practical to increase safety for the motoring public. Implementation of this policy will require that aerial facilities be joint-use and be placed outside the clear roadside area for new installations, upgrading of facilities as per Chapter 8 of this Manual, and relocations due to Department's construction or as part of a separate safety project.

In an effort to reduce the number of roadside obstacles, the Department will require that any Utility who is relocating poles or attaching to existing poles on the right-of-way is to be responsible for filling out the Dual Pole section in GUPS. This will identify the name(s) of other Utilities that are to occupy the joint use poles or are currently on existing poles, the contact person(s), phone number(s), and location by mile marker on said State Route.

### **3.6.B. Construction and Work Requirements**

**3.6.B.1. Compliance with Plans** - The Utility's completed facility shall be in substantial conformance with the plans required by Section 3.6.A (above). When changes to an approved permit are required on construction, the Utility shall request and receive approval of said changes by the District Utilities Engineer before constructing. The Utility shall then prepare revised "as built" plans and furnish two

copies to the District Utilities Office for the Department's permit record files.

**3.6.B.2. Work Standards** - All work in connection with the facility authorized by the permit shall be done in a neat and workmanlike manner to the satisfaction of the Department. All utility installations shall also conform with the applicable sections of this Manual and current editions of the Department's Standard and Supplemental Specifications and/or Special Provisions, and Construction Standards and Details; rules and regulations of the Public Service Commission (PSC); the National Electrical Safety Code (NESC), the American Water Works Association (AWWA) standards, the recognized ANSI standard code for the type of facility to be installed, the "Americans with Disabilities Act" (Title 42 USC Chapter 126), all other applicable governmental codes and regulations, and any Special Provisions which may be made a part of the permit by the Department.

**3.6.B.3. Notice of Work Beginning** - The Utility shall contact the Department's Area Engineer or Area Permit Inspector at least 24 hours before starting any work to discuss the work schedule and temporary Traffic Control Plan in order to review for any changes from the initial submittal and for understanding by all parties prior to occupying the work site. At such time, the Area Engineer or Area Permit Inspector will notify the Utility of any work hour restrictions, moratoriums on traffic interruptions, or other issues that may affect the proposed work.

**3.6.B.4. Notice of Work Completion** - The Utility shall notify the Area Engineer or Area Permit Inspector when the installation authorized by the permit has been completed so that an inspection can be made by the Area Engineer or Area Permit Inspector to ensure that provisions of the permit have been met and that all areas within the right-of-way have been adequately restored.

## **3.7 TRAFFIC PROTECTION**

**3.7.A. General** - The Utility shall be responsible for the overall selection and installation of the appropriate traffic control devices. The Utility will plan and determine the scope of a temporary Traffic Control Plan (TCP). A TCP describes temporary traffic control measures to be used for facilitating road users through a work zone. The degree of detail in the TCP will depend on the

complexity of the work and traffic interference. The TCP shall include, but is not limited to, defining all materials, traffic control devices, traffic diagrams, pacing of traffic, and other activities required to accomplish the work. The conditions in each work zone will vary and all factors should be considered in determining the appropriate traffic control requirements. The TCP should start in the planning phase and continue through design, construction and restoration phases of the work.

The Utility shall indicate on each individual permit application whether the TCP is based on the typical application drawings contained in Part 6 of the MUTCD or a detailed TCP designed solely for a particular work site or a combination of both. If the Utility determines that a detailed TCP designed solely for a particular work site is needed, a copy of the detailed TCP shall be submitted with the permit application. The Department reserves the right to request a detailed TCP upon review of the permit applications. The detailed TCP will be reviewed by the Department. This is a general review by the Department and is not an approval or guarantee that the methods proposed by the Utility will be suitable for the field conditions that may be encountered.

- 3.7.B. Interstate and Limited Access Highways** - The Utility shall provide a detailed TCP with each individual permit application for all proposed work in, on, along, over or under interstate and limited access highways.
- 3.7.C. All Other Routes** - For all other routes not included in Section 3.7.B, the Utility shall follow the general requirements listed in Section 3.7.A.
- 3.7.D. Worksite Traffic Control Supervisor (WTCS)** - For any work performed in, on, along, over, or under the right-of-way, the Utility shall designate a qualified and adequately trained person as the WTCS. The WTCS will have the primary responsibility and sufficient authority for assuring that the TCP and other safety aspects of the work are effectively administered. The WTCS shall be available on a 24 hour basis to perform his duties. The WTCS's traffic control responsibilities shall have priority over all other assigned duties. If the work requires traffic control activities to be performed during both daylight and nighttime hours, it may be necessary for the Utility to designate an alternate WTCS. An alternate WTCS must meet the same requirements and qualifications as the primary WTCS. The WTCS shall be responsible for administering the selection, installation, inspection and maintenance of all traffic control devices in accordance with the TCP, project plans, specifications, special provisions and the MUTCD. The WTCS shall be available on a full-time basis to maintain traffic control devices with access to

all personnel, material, and equipment necessary to respond effectively to an emergency situation within 45 minutes of notification of the emergency. The WTCS shall regularly perform inspections to ensure that traffic control is maintained.

- 3.7.E. Notice of Work Beginning** - The Utility shall contact the Department's Area Engineer or Area Permit Inspector at least 24 hours before starting any work to discuss the work schedule and temporary Traffic Control Plan in order to review for any changes from the initial submittal and for understanding by all parties prior to occupying the work site. At such time, the Area Engineer or Area Permit Inspector will notify the Utility of any work hour restrictions, moratoriums on traffic interruptions, or other issues that may affect the proposed work.

### **3.8 MAINTENANCE**

- 3.8.A. General Restrictions** - The Utility shall at all times keep facilities authorized by the permit in a good state of repair from the standpoint of both structure and appearance. The Department may revoke the permit and order removal of any facilities that become a hazard to the public or detrimental to the roadway due to improper maintenance practices.

- 3.8.B. Maintenance Activities** - The activities listed below shall be considered as incidental to operation and maintenance of the facilities installed within the right-of-way and will not require separate written authorization (i.e. permit or agreement as per Section 2.5.C of this Manual); however, in such cases that require the blocking of one or more traffic lanes for a period of time in excess of 1 hour, the Department will require notification. The Utility shall give advance notification in accordance with Section 3.7.E of this Manual.

*Note (as referenced in Section 3.1 of this Manual): Activities including installation or replacement of a pole, excavation in the roadbed structure, cutting of pavement, boring beneath the pavement or introduction of new obstructions onto the right-of-way are not considered maintenance activities and will require a permit. If any of the previously mentioned activities are considered as an emergency, reference Section 3.9 of this Manual.*

- 3.8.B.1. Replacement of any Component Parts** - The replacement of any component parts, not including poles or cables, which become necessary due to damage, deterioration or obsolescence. Any

replacement shall not affect vertical or horizontal clearances from the traveled way or shall not change the rated capacity or transmittant of the facility for which a permit was issued.

**3.8.B.2. Installation of Lateral Service** - The installation of lateral service connections to serve occupants of adjacent property provided that they do not cross or begin in the roadbed structure and are at a right angle to the pavement (i.e. “short-side” service).

**3.8.B.3. Installation of Additional Appurtenance** - The installation of additional appurtenance or attachments to facilities which do not affect vertical or horizontal clearances from the traveled way or do not change the rated capacity or transmittant of the facility for which a permit was issued.

**3.8.B.4. Routine Inspection** - Periodic, routine inspection, testing, and preventive and routine maintenance to ensure that facilities are retained in a serviceable condition and good state of repair at all times.

### **3.9 EMERGENCIES**

**3.9.A. General** - During an emergency situation, the Utility should protect the public safety by making necessary repairs to the existing facilities complying, as much as is practical, with the requirements of this Manual. The Utility will assist the Department in restoring damaged or closed transportation facilities by expediting the engineering, scheduling, and other activities required to meet the accelerated construction deadlines and for the protection of existing facilities which may include relocations and/or adjustments, whether temporary or permanent. No advanced permit approval is required. However, notification is required and an Emergency Utility Permit shall be submitted utilizing GUPS within 5 business days after the onset of the emergency for any excavation or boring within the roadbed structure, or cutting of any paved surface, or the replacement of any poles. Upon notification of an emergency Let project(s), the Utility shall submit the required Work Plan as the accelerated schedule demands.

**3.9.B. Notification** - If an emergency situation occurs, the Utility shall notify the Department to obtain an Emergency Permit Authorization Number. This verbal approval shall be gained as soon as practical, but no later than 24 hours after the onset of the emergency. The authorization number will be provided to the Utility with the completion and approval of the Emergency Utility



Permit Checklist by the District Utilities Engineer, Area Engineer or Area Permit Inspector. If the emergency occurs during non-business hours, including weekends, the Utility shall contact the Department's emergency operations number at 511 or 1-877-694-2511 (Statewide).

### **3.10 ADDITIONAL APPROVAL AND NOTICE OF OTHER AGENCIES**

- 3.10.A. Additional Permit or License** - Nothing in the permit shall be construed to grant rights or imply approval in areas not falling within the authority and jurisdiction of the Department. It shall be the responsibility of the Utility to determine the need for, and to obtain, such license, permit, or other form of approval that may be required by other State or Local agencies, Federal agencies, or Railroads.
- 3.10.B. New Utility Installations on Projects under Construction** - It shall be the responsibility of the Utility to furnish a Utility Adjustment Schedule for making a new utility installation that is compatible with project construction when highway construction is underway. Written approval of such schedule by the Contractor shall be furnished to the Department's engineer having jurisdiction over the project prior to beginning work. Upon request the Department will assist in resolving any disputes over utility adjustment schedules or in arranging for emergency access to utility facilities within a project under construction.
- 3.10.C. Notice to Others** - The Utility shall give due notice to other Utilities through the Georgia811 of any other known overhead, underground or other utility facilities at the described location which may be impacted by the installation. The information required for this notice shall be in accordance with the procedures developed by the Georgia811. Refer to O.C.G.A. § 25-9-1 and 46-3-30 for more information.

The Department encourages the use of NJUNS for Utilities to obtain information on a variety of shared concerns, including pole transfers, new attachments to poles, and joint trenching. As per Section 3.6.A of this Manual, it will be the responsibility of the Utility to notify all other pole occupants of the permit approvals and installation completion so that the next Utility can transfer their facilities.

The Department encourages participation in the Department's District Utilities Quarterly meetings and local GUCC meetings in the interest of

receiving advance information on capital construction programs and any other significant project(s) which may affect other stakeholder's assets and schedules.

### **3.11 EFFECTIVE PERIOD OF PERMIT**

- 3.11.A. Term of Permit** - If work begins within 12 months after issuance, and unless otherwise provided in the Special Provisions, the permit shall be in effect for an indefinite period of time from and after the date approved, unless sooner revoked by mutual consent or by the Department for failure of the Utility to abide by the terms and conditions of the permit or by operation of law. A permit is automatically revoked when the Utility for which the permit is issued ceases or abandons the operations.
- 3.11.B. Cancellation for Cause** - Failure of the Utility, within a reasonable time after written notice from the Department, to comply with any of the terms and conditions of the permit shall be sufficient cause for cancellation of the permit.
- 3.11.C. Assignment or Transfer** - The permit, and the privileges granted, and the obligations of the Utility created thereby, shall be binding upon the successors and assigns of the Utility. The Utility shall give the State Utilities Engineer written notice of any such assignment or transfer within a reasonable time thereafter. The notice shall include the following: Original Utility name; New Utility name; Effective date; means of change (shareholder approval, sale of Utility, buyout, court order); verification of pending or completed publication of "Notice of Change of Corporate Name" pursuant to O.C.G.A. § 14-2-1006.1(b).
- 3.11.D. Time Limit on Beginning Work** - The Utility shall commence installation of the utility facility covered by the permit within 12 months from the date the permit is approved, otherwise the permit shall expire and a new permit will be required.
- 3.11.E. Changes Subsequent to Permit Approval** - The Utility shall obtain Department approval prior to any change of transmittant or increase in working capacity or maximum pressure. A new permit may be required.

**3.11.F. Large Projects** - The majority of, if not all, Department projects are considered Large Projects as defined in O.C.G.A § 25-9 and as stated in the PSC Rule 515-9-4. Because Department projects typically last more than 90 days or are more than one linear mile, all Utilities involved with active projects will treat them as a Large Project. It is the responsibility of the Department's Contractor to follow the procedures for notifying Georgia811 of a Large Project Notification. If the Department's Contractor decides to treat the active project as a Large Project, the Utilities and any Utility excavator performing utility relocation or adjustment work on behalf of the Utility, as directed by the Department in accordance with O.C.G.A. § 32-6-171, will participate and make the necessary arrangements to locate their facilities for the Contractor on an as needed basis. Any contractual relationship that may be required will be handled separately between the Contractor and Utility. The Utility(ies) shall not invoice the Contractor or any excavator working under the Contractor on Department projects for their costs of any re-marking requests.

### **3.12 IDENTIFICATIONS**

**3.12.A. Worksite Identification** - In order to identify the work during installation, the Utility shall place a card sign, or signs, on the highway near the work before beginning the installation. The sign shall be visible from the traveled way and shall be placed not less than 6 feet above the ground and at least one per mile. The sign or signs will be furnished to the Applicant by the Department along with the approved permit.

**3.12.B. Vehicle and Equipment Identification** - The exterior sides of any vehicle and equipment used in conjunction with any activity within the right-of-way must be clearly marked or labeled, identifying the Utility for which the work is being performed, as well as the contractor(s) performing the work for the Utility.

### **3.13 COORDINATION OF REQUIREMENTS**

In the case of any discrepancy between the requirements of this Manual and the Plans or Special Provisions attached to the permit, the following order of control shall govern:

1. Special Provisions (including any exceptions to the Manual as approved by the Department).

2. Manual.
3. Plans accompanying permit.

## **CHAPTER 4: UTILITY ACCOMMODATION, RELOCATIONS, AND ADJUSTMENTS ON PROJECTS**

### **4.0 GENERAL PROVISIONS**

This chapter prescribes policies, procedures, standards, and practices for the statewide coordination of utility relocation required for the construction of transportation projects. The chapter is organized based on the usual sequence of events from project inception (planning/concept phase) to project construction phase completion. Although it is impractical to include all policy interpretations and instructional material, this chapter does contain most information required to do the job. Separate Department policy memorandums supplement guidance contained in this chapter provide background or guidance on subjects that occur less frequently.

**4.0.A. Roles and Responsibilities** - Each task or procedure provided in this chapter lists an overseer who is responsible for ensuring that each step is completed properly. The following summary briefly describes the responsibilities of those involved in utility coordination on Department projects.

#### **4.0.A.1. State Utilities Office -**

- a. Creates and conveys GDOT utility policies and regulations for the efficient and equitable accommodation of Utilities on GDOT Projects
- b. Has final approval authority of all Utility Agreements, Utility Permits, Relocation Plans, and utility certifications
- c. Prepares and processes all Utility Agreements. Provides authorization for the Utility to incur reimbursable costs associated with subject Utility Agreements. Also acts as liaison between the District Utilities Office and the Utility and serves as central resource for utility issues.
- d. Administers and manages the statewide Overhead/Subsurface Utility Engineering (SUE) program for specified GDOT Let projects
- e. Processes all Utility-Aid requests submitted by Local governments through the District Utilities Office requesting financial assistance on Department projects (See policy 6863-11)
- f. Reviews and approves all utility retention requests submitted by the Utility through the District Utilities Office

- g. Certifies, at a time prescribed by each project schedule, that all foreseeable utility conflicts are resolved and that all utility agreements and negotiations have been completed with arrangements made for the physical utility relocation work to be undertaken
- h. Manages all Utility Agreement processes from project inception (planning/concept phase) to project construction phase through project completion and final audits.

**4.0.A.2. District Utilities Office** - The District Utilities Office is responsible for coordinating the relocation or removal of utility facilities that are either in physical conflict or in violation of the Department's *Utility Accommodation Policy and Standards* for transportation projects, including Local Let projects, in which the Department is providing funding or other administrative responsibilities in accordance with the Project Agreement as per Section 4.2.A.1.a of this Manual. The District Utilities Office typically:

- a. Prepares the agenda, conducts and records minutes as required for each Quarterly District Utilities Coordination Meeting
- b. Establishes project utility files that document actions taken or recommended during the life of a project. The diversity and complexity involved in the relocation of utility facilities and their potential safety impacts makes it mandatory that files be established and thoroughly documented. Any discussion, meeting, or review of importance that does not generate a document for the file should be recorded in a memorandum. The project file is critical for maintaining current project status or for documenting past actions. Each District Utilities Engineer should consider the needs and methods of their district and initiate procedures for establishing and maintaining project files. The author should date and sign or initial all entries and notations in the file.
- c. Establishes project timelines, deadlines, and utility deliverable submittal requirements for each phase or activity assigned.
- d. Prepares and issues Notices to Proceed to the Utility for both preconstruction activities and construction activities (not covered by a Utility Agreement; see Section 4.0.A.1.c above).
- e. Acts as the Department's primary point of contact with the Utility for identifying and verifying all utility facility impacts lying within the limits of planned construction projects.
- f. Identifies the need for an Overhead/Subsurface Utility Engineering (SUE) investigation, and provides recommendations

- of the required scope (Quality Level) to address utility issues, document conflicts, and coordinate relocations.
- g. Prepares concept utility impact route estimates based on possible relocations. These estimates are used for capital and support budgeting needs for current and future fiscal years.
  - h. Coordinates location requirements for all utility facilities within the project limits. This includes acting as the Department's primary contact for plan submissions between the GDOT and each Utility.
  - i. As required by a project's complexity and utility impacts, coordinates and conducts project utility impact meetings with the Utility/operators to assess and explain the impact of the project. The Department's Project Designer, District Construction Engineer (or designee), should be included in these meetings as well.
  - j. Attends and participates in Concept and Field Plan Review Meetings to ensure utility issues are addressed and documented in respective Concept and Field Plan Review Meeting Reports. Attends and invites utility or railroads to attend Public Information open house and provide project information and seek identification of major concerns.
  - k. Coordinates preparation and review of necessary property right conveyances for the Utility. Obtains and analyzes data to allocate cost between the Utility and State for all required utility adjustment work and to clearly document, support, and set forth the basis of this finding in a utility adjustment/relocation estimate and Certificate of Eligibility.
  - l. Reviews and provides recommendations for approval and forwards all utility retention requests to the State Utilities Office for final approval, with the exception of retention requests on driveway permits not in excess of 500 feet may be approved by the District Utilities Office.
  - m. Prepares and issues Utility Permits in accordance with Chapter 3 of this Manual.
  - n. Secures all utility plans and specifications, cost estimates, certification letters, Work Plans, and Utility Adjustment Schedules from all Utilities located within the subject project's limits within the prescribed timeframe stipulated for each project
  - o. Maintains the Department's project tracking database to ensure that all utility related project information is kept current.
  - p. Provides recommendation to the State Utilities Office at a time prescribed by each project schedule that all foreseeable utility

conflicts are resolved and all utility plans, specifications and cost estimates, and negotiations have been completed with arrangements made for the physical utility relocation work to be undertaken.

- q. Attends Construction Transition Conferences to explain unique utility or railroad issues to the design and construction team as needed to facilitate the construction as shown on the project plans and Utility Work Plan.
- r. After receiving notification concerning the date, time, and place of the Preconstruction Conference from the Area Engineer, forwards notification via electronic mail to all utilities identified as having facilities within the project limits with copies of notification being sent to the State Utilities Engineer, District Construction Engineer, and Area Engineer. Attends project Preconstruction Conferences to provide an overview of any utility or railroad items that relate to the contract documents; Utility or railroad agreements; Work Plan; and discuss any special situations that may impact the project construction.
- s. As requested by the State Utilities Office, verifies Utilities relocation bills, revised estimates, contract bid tabulations, and construction changes, and recommends approval of any cost overruns as applicable.

#### 4.0.A.3. Utility -

- a. Is responsible for obtaining written approval prior to commencing with the physical construction, installation, relocation or adjustment of any utility facilities that occupy or propose to occupy existing or proposed rights-of-way of active projects. The Department shall provide written approval by the following methods:

**Approval by Permit** - When a utility is to remain on public right-of-way, and the relocation or adjustment of such facilities is required; then a GUPS Permit must be completed and on file with the Department. (Also, see Section 2.5.C of this Manual). When a permit has been previously executed, it will not be necessary to execute a new permit unless the Utility proposes to make changes, other than maintenance and addition of appurtenances in conjunction with the project. (See Section 3.8 of this Manual.)

**Approval by Agreement** - On projects involving utility relocations or adjustments that have been determined to be eligible for reimbursement by the Department under the



reimbursement classifications identified in Section 4.2.A.1 of this Manual, the Utility and the Department shall agree in writing on their separate responsibilities for funding and accomplishing the work. The written agreement shall specify the terms and amounts of any credits or refunds made or to be made by the utility to the Department in connection with payments by the Department to the utility. In order to ensure that funding for reimbursement of relocations or adjustments will be secured and to avoid delays to the project, all arrangements (as set forth in this chapter) for reimbursement must be completed prior to award of the Department project. In addition, agreements must be executed prior to project certification deadlines; otherwise, the Department may be denied federal participation. Please see Sections 4.2 and 4.3 of this Manual for further information regarding agreements.

- b. Is responsible for providing written confirmation to the Department acknowledging the receipt of all Project information request packages
- c. Is responsible for verifying their facilities on preliminary plans, reviewing Department project design plans, cooperating with GDOT SUE and Utility Coordination consultants
- d. Is responsible for participating in Department Quarterly District Utilities Coordination Meetings, and planning their resources to accommodate GDOT on such projects identified in the Department's Construction Work Program
- e. Is responsible for participating in concept, design and related utility coordination meetings, submitting relocation plans and schedules, and coordinating their relocation work with GDOT and its Contractors.

#### **4.0.B. Project Related Dispute Resolution -**

- 4.0.B.1. General Description** - As provided in O.C.G.A. § 32-6-171(d) and Section 2.8.D of this Manual, procedures and mediation boards shall be created to resolve disputes that may arise between the Department and the utility concerning matters related to the authority of the Department to order the removal and relocation of utility facilities occupying the public road system to accommodate a Department's project construction. In the event that an issue should arise that is not specifically covered in Sections 4.1.C.4, 4.4.B and 4.4.C of this Manual, such issue shall follow the same escalation path as is described by Section 4.1.C.4 of this Manual.

#### 4.0.C. Overhead/Subsurface Utility Engineering (SUE) Investigations -

**4.0.C.1. General Description** - The GDOT administers a SUE Program to manage the risks associated with existing utility facilities found on active Department projects. GDOT's SUE Program employs established engineering technologies that can provide precise horizontal and vertical locations of existing overhead/underground utilities to produce an accurate picture of the existing overhead/underground utility infrastructure. The techniques of SUE may be appropriate for certain Department projects where enhanced Quality Levels of Service for existing utility information are determined to be essential for the design analysis of road improvement and widening projects.

Accurate and comprehensive horizontal and vertical location data for all existing utilities found within a project's limits makes it possible to:

- Design around many utilities, thus avoiding costly and time-consuming relocations  
AND/OR
- Accurately depict existing utilities on construction plans so the Utilities, the Department and its Contractors will have more accurate locations of existing utilities and will be able to consider any mitigation needs before any excavation takes place.

The following Quality Levels of Service for existing utility information can be found on Department project utility plans where SUE has been employed:

- **Quality Level "D" Information** - Information derived through existing records or oral recollections. This also includes an in-field visual site inspection to verify credibility of such records. Quality Level "D" is typically applied when it is necessary for the designer to make broad decisions about route selection, purchasing right-of-way, or producing a higher level of data. This level of information is typically recommended during a project's concept development.
- **Quality Level "C" Information** - Information obtained to indicate the presence and approximate horizontal location of underground utilities by surveying visible above-ground utility features, such as manholes, valve boxes, posts, etc., and by using

professional judgment, correlating this information with existing utility records (Quality Level “D”). Quality Level “C” is typically used on rural projects and is recommended when preliminary design begins and project mapping and survey control have been established.

- **Quality Level "B" Information** - Information obtained to indicate the presence and approximate horizontal location of underground utilities using geophysical prospecting techniques, including electromagnetic, magnetic, sonic, or other energy fields. The data obtained from these methods should be reproducible by surface geophysics at any point of their depiction. This level of information is used by the designer to make educated decisions on where to place storm drainage systems, footings and foundations to avoid conflicts with existing utility facilities. Quality Level “B” is typically used on urban type projects and is recommended when preliminary design begins and project mapping and survey control have been established.
- **Quality Level "A" Information (Test Holes)** – Information to obtain the precise horizontal and vertical position of the utility line by excavating a test hole. The test holes shall be done using vacuum excavation or comparable nondestructive equipment in a manner as to cause no damage to the utility line. This level of information provides three dimensional (x, y, z) mapping of specific conflict areas needed for final design and utility placement decisions where drastic cost savings will be incurred for the project. Quality Level “A” is recommended after Preliminary Field Plan Review ideally following a Utility Impact Analysis.
- **Utility Impact Analysis (UIA)** – The UIA includes a conflict matrix which is used to determine to what extent the proposed roadway improvements will impact the existing utilities. It is a report, typically a spreadsheet, outlining avoidance alternates, required adjustments/relocations, and cost estimates to perform those relocations. The UIA is typically recommended after Quality Level “B” but prior to Quality Level “A” (when there is enough proposed design information available) and is used to determine which Quality Level “A” (Test Holes) may be performed.

It is recommended that a UIA be requested right before the Preliminary Field Plan Review. However, a UIA is iterative and

may also be requested and performed after 2<sup>nd</sup> submission to the Utility Owners to resolve any new or remaining utility conflicts.

**4.0.C.2. Implementation of SUE** - The Department requires the use of SUE on most design-build projects and recommends that District Utilities Engineers and Project Managers consider its use on any project where inaccurate underground utility information would negatively impact the project in a significant way.

Project candidates to employ SUE should be submitted to the State Utilities Office by the District Utilities Engineer or GDOT Project Manager as early as possible in a project’s development. For additional information regarding SUE project requests, please refer to the SUE pages on GDOT Utilities webpages.

The proper implementation of SUE in relation to the project’s development is critical to maximizing its usefulness in utility conflict avoidance. Below is a general guide as to when each Quality Level of SUE investigation should begin for each major phase of project development.

<i>Project Development Phase</i>	<i>% Design Complete</i>	<i>SUE Investigation Quality Level</i>
Conceptual Design Phase	0-10%	Quality Level D
Preliminary Design Phase	10-30%	Quality Level C/B
	30-60%	UIA (1 <sup>st</sup> )
Final Design Phase	60-70%	Quality Level A
	70-90%	UIA (2 <sup>nd</sup> , if applicable)

## **4.1 UTILITY PROJECT DEVELOPMENT PROCESS**

From the early stages of project planning through the final development of construction projects, the Department will coordinate with utilities according to the policies and procedures set forth in this Manual, and the Department’s Plan Development Process (PDP) policy, current edition. This coordination is necessary to determine the scope of utility involvement and allow reasonable notice for the utilities to make arrangements for unavoidable relocations. The Utility, the Department’s Project Manager, and the District Utilities Engineer review the location of utilities within and near the project limits at multiple times during the development of a project to determine their proposed disposition. In cases where suitable arrangements

cannot be made in accordance with the policies and standards, as outlined in this Manual and elsewhere, a pre-design conference may be called with the Utility and the Department's District Utilities Engineer to make special provisions for accommodating or relocating the Utility's facilities.

**4.1.A. Planning/Concept Phase** - It is imperative that current information on the Department's proposed Construction Work Program be provided to the Utilities so that they may plan their necessary work as far in advance as practical. Such early planning is critical to avoid unnecessary utility impacts that may delay the Department's projects.

**4.1.A.1. Quarterly District Utilities Coordination Meetings** - In order to provide information on the Department's Construction Work Program and to discuss proposed projects with utility companies on a regular basis, it is the Department's policy to conduct quarterly meetings for each District. All Utilities will be invited and encouraged to attend these meetings. The District Utilities Engineer shall conduct these meetings with participation by the District Pre-Construction Engineer, or their representative. Printed information on the Construction Work Program will be provided to the Utilities to the extent possible without compromising any confidential or otherwise sensitive information. The Construction Work Program will be reviewed on a county by county basis for at least a 1 year period. Information beyond that time can be provided in the printed matter or reviewed individually with the utility companies as desired. Particular items that need to be addressed as a minimum are as follows:

- Utilities will be asked to advise the Department of any unusual problems anticipated for projects scheduled for advertisement within the next twelve months.
- Utilities will be asked to advise the Department and other Utilities about plans for construction of new utility facilities affecting the existing or proposed right-of-way.
- Utilities will be requested and encouraged to discuss their plans for significant construction during these meetings. This can serve as a basis of early discussion as to the acceptability of proposed routes and avoid possible conflicts with other construction.
- Utilities will be requested to identify candidate projects to employ Overhead/Subsurface Utility Engineering (SUE) investigations.

Such issues identified at the meeting will be recorded by the District Utilities Engineer and used as an aid in coordination efforts during the Concept and Design, and Construction Phase of the respective project's development.

The Department will schedule each year's meetings well in advance and notify the Utilities of the scheduled Quarterly Meeting dates through the Department's website. The meetings will typically be held at the respective District Office. Please note that Railroads are to be included in these meetings also.

**4.1.A.2. Project Concept Development** - The objective of a project's Concept Development is to develop an Overall Project Concept Report that will describe a recommended project "footprint" including logical termini. A project recommendation will be made for a "Build Alternative" or "No-Build Alternative" that addresses the "Need and Purpose" of the programmed project after preliminary traffic and operational studies, accident analysis, determination of project deficiencies, planning requirements, environmental cruise (an on-site, drive thru, screening of the project area), study of alternatives, permit requirements, social and economic considerations, utility considerations, right-of-way impacts, and other analyses have been made.

The District Utilities Engineer will perform the following tasks to ensure proper utility coordination is performed during Concept Phase of a project's development.

***Prior to Concept Team Meeting:***

- Perform an initial utility impact survey by driving through the project's termini to identify obvious utilities, type of facilities, and general utility location (i.e. left/right side of roadway). Specifically, identify any major utility facilities such as electric transmission lines, substations, remote terminal (RT) sites, pipelines, gas risers, etc. Whenever possible, identify which facilities are located on and off existing right-of-way.
- Make contact with each Utility to ensure each is aware of the general scope and nature of the Department project and request that each submit a written response which includes a cost estimate and comments concerning potential impact to their facilities. Additionally, in this response the Utility should provide an indication of whether their facilities could be included in the Department's project construction contract.

- Notify and invite each Utility to attend the Department's Project Concept Team Meeting.

***During Concept Team Meeting:***

- Participate in the project Concept Team Meeting. Present all utility impacts and respective cost estimates known to date. Record any new impacts or project changes that may affect utilities.

***After Concept Team Meeting:***

- Based upon the outcome of the Concept Team Meeting, make contact with each Utility to update each on the scope and nature of the Department's project and request that each submit a revised cost estimate and comments concerning potential impact to their facilities.
- Develop and submit to the GDOT Project Manager, and State Utilities Engineer a Concept Utility Report. The data in this report is to be used by the Department's Project Manager for inclusion into the Project's Overall Concept Report. This report shall include the following minimum information:
- Provide a list of all Utilities found within the project's limits including the Utility name, a point of contact with address, telephone, and email address.
- Provide a general description of each utility, i.e. type, size, material, and general location.
- Provide a statement of proposed utilities to be installed in the near or distant future.
- Recommend to State Subsurface Utilities Engineer (SSUE) if SUE should be employed and provide the required information (i.e. Utility Impact Rating Form, Quality Level) for an Overhead/Subsurface Utility Engineering (SUE) investigation to address utility issues, document conflicts, and coordinate relocations.
- Provide a conceptual estimate of reimbursable and non-reimbursable utility relocation costs for each Utility.
- Provide a summary of potential utility impacts for each of the Utilities facilities. Identify potential conflicts with major utilities which could have a substantial economic impact to the project or the Utility.

- Provide recommendations of possible alignment and grade alternatives to minimize major project utility impacts. Such impacts and recommendations should be taken into consideration in finalizing the preliminary project scope and Concept Report.

**4.1.B. Public Information Meetings and Reviews** - These meetings and reviews are another opportunity for the Utility to communicate early and often in the Plan Development Process (PDP). These are various group meetings which may be advertised as Public Information Open House, Notice of the Opportunity for a Public Hearing Open House, and Public Hearing Open House. The Department may utilize Public Information Meetings to inform utilities, Local government officials, stakeholders, and the general public of proposed projects in their area.

**4.1.C. Project Design Phase** - The Design Phase of the project begins at the onset of project Concept Report approval and is complete upon submission of final plans/contract documents for project Letting. The purpose of this phase is to develop the project plans, utility adjustment schedules/utility work plans, utility relocation plans, and associated agreements necessary to address all foreseeable utility impacts that might affect the project. This includes utility issues affecting right-of-way acquisition, environmental clearances, project staging, and project constructability. Upon successful completion of the coordination tasks required throughout the project design phase; the Department would be prepared to acquire right-of-way, address all environmental issues, and be prepared to go to bid for the construction of the project with all foreseeable utility project impacts addressed. To this end, utility facility conflict identification and resolution are critical for this phase of project development.

The utility coordination tasks required to successfully complete this phase of project development typically consist of multiple and sometimes iterative plan submittals and utility coordination meetings between the Department and each impacted utility facility. The District Utilities Engineer and the Utilities are jointly responsible for ensuring that these tasks are completed properly.

The typical sequence of events that should be completed for all projects during this phase is as follows:

1. Identify/confirm locations of existing utility facilities in relation to the project's construction limits.
2. Develop preliminary project design and identify preliminary conflicts/impacts with existing utility facilities.



3. Coordinate with the Utility to obtain proposed retention requests.
4. Begin preliminary utility conflict avoidance - revise project preliminary design to minimize foreseeable utility impacts for 1 and 2 above.
5. Determine if it is possible to include Utility Relocations into the Department's project construction contract to expedite project staging.
6. Develop/obtain approved utility relocation design and Work Plan to accommodate project.
7. Determine relocation costs and associated responsibilities between Department and the Utility.
8. Finalize design for project and utility relocations.
9. Review and recommend plans, specification and cost estimate packages for the execution of agreements as required to satisfy funding responsibilities.
10. Certify project as ready to Let to construction.

The following sections detail the above general outline of the tasks performed during the project's Design Phase.

**4.1.C.1. Utility Plan Development** - Utility Plans are used as the primary tool to identify and resolve utility related conflicts/issues prior to beginning the construction of a project. Utility information shown on the Utility Plans is obtained from either an Overhead/Subsurface Utility Engineering (SUE) investigation and/or the affected Utility.

The first task required in the development of the Utility Plans is to identify/confirm locations of existing utility facilities in relation to the project's construction limits. Determining the location of existing utilities is a cooperative effort between the Department and the Utility. The degree of effort exerted on the part of the Department and the Utility to determine the location of existing utilities will vary with the type of project, utility type, project schedule, and the project location.

- a. **1st Submission of Utility Plans** - Those projects that have been determined to have relatively low utility impacts will typically not employ an Overhead/Subsurface Utility Engineering (SUE) investigation. For these projects, the Department's District Utilities Engineer will submit preliminary roadway plan sheets along with a written request for the Utilities to provide the locations of their existing utility facilities. This submission of plans is commonly referred to as the "1st Submission". To avoid transcription errors, electronic submission is encouraged. When electronic submission is used, the Utilities shall adhere to the Department's line symbology and data transmission procedures.

The existing utility information obtained from this “1st Submission” typically comes from utility records and is therefore classified and depicted on the Utility Plans as Quality Level “D”.

When it has been determined that a project requires a higher degree of effort due to higher probable utility impacts, the Department will perform an Overhead/Subsurface Utility Engineering (SUE) investigation to locate and map the locations of the existing utilities. The SUE will take the place of “1st Submission” to the Utilities. For SUE projects, the SSUE will determine the appropriate Quality Level. All SUE deliverables must be reviewed and accepted by the SSUE’s office before inclusion into the Utility Plans.

The District Utilities Engineer will still submit the accepted SUE deliverables to each Utility found within the project’s limits to request that the Utility provide a confirmation of the utility locations found during the SUE investigation and to provide a plan submission of their preliminary utility relocation design.

The preliminary utility relocation design is intended to be used on projects whose utility impacts are relatively high. Such a preliminary relocation design should provide enough information to identify and address probable utility impacts early in the design phase with a focus on the acquisition of right-of-way and impacts to environmental resources. Thus, this submission should be performed well in advance of the Department’s Right-of-Way Plan approval and environmental document clearance.

It is the Utilities responsibility to return or electronically transfer the complete package requested by the District Utilities Office within the time period prescribed in the respective “1st Submission” request letter. Please see Section 4.1.C.1.c of this Manual for the recommended deadlines that pertain to each project type.

- b. **2nd Submission and Resubmission of Utility Plans** - As the project design proceeds to the point that all proposed changes that may affect utilities are known; a “2nd Submission” request will be sent (or electronically transferred) from the District Utilities Office to each Utility found within the project’s limits. This “2nd Submission” will include a request letter, current construction plans, including staging plans, cross sections, drainage profiles, and preliminary bridge/wall plans. In some

cases “1st Submission” and “2nd Submission” will be requested concurrently.

In this written correspondence, the Utility will be requested to show any adjustments or relocations necessary to accommodate the construction of the project. Additionally, the Utility will be responsible for verifying the accuracy of existing facilities previously submitted, identified by a SUE investigation, or mapped by the Department. The Utility will also be responsible for adding any utility information not shown and for preparing any detailed staging plans showing necessary adjustments, temporary installations, and relocations of their facilities to conform to the highway construction requirements and the provisions of this Manual.

A set of marked plans, along with a Work Plan (including a Utility Adjustment Schedule (UAS)) indicating the type of facilities, the work to be accomplished, the relocation requirements, the staging requirements, and the number of work days required to complete the utility work, will be returned or electronically transferred to the District Utilities Office within the time period prescribed by the Department for review and approval. Additionally, at this point in the project’s development, the Utility will provide an estimate for the costs associated for the relocations and adjustments required to accommodate the project. This estimate shall follow the requirements set forth in Section 4.2 of this Manual. To avoid transcription errors, electronic submission is encouraged. When electronic submission is used, the Utilities shall adhere to the Department’s line symbology and data transmission procedures.

The District Utilities Engineer will consult with the Department’s Project Manager and District Construction Office as necessary to ensure that the utility relocation design and Work Plan are reasonable to accommodate the project. Upon approval of the submittal, the Department’s Project Manager will be responsible for incorporating all information into the plans and special provisions

If the project’s design is modified from that which was provided to the Utility at the “2nd Submission” request; it may be necessary for the Department’s District Utilities Engineer to request a “Revised Plan Submission” from the Utility for confirmation or changes in the adjustment and relocation design, Work Plan/UAS, etc. to accommodate the revised project design.

If such a “Revised Plan Submission” is found necessary, the same submittal process as described above for “2nd Submission” shall be employed.

It is the Utilities responsibility to return or electronically transfer the complete package requested by the District Utilities Office within the time period prescribed in the respective “2nd Submission” or “Revised Plan Submission” request letter. Please see Section 4.1.C.1.c of this Manual for the recommended deadlines that pertain to each project type.

1. **2nd Submission - No Conflict Anticipated** - Once the Utility has verified the accuracy of existing facilities previously submitted, identified by a SUE investigation, or mapped by the Department and has determined that no conflict is anticipated, a letter shall be submitted to the District Utilities Office, in that regard, within the time period prescribed in the respective “2<sup>nd</sup> Submission” or “Revised Plan Submission” Utility Relocation Procedure Notification “URPN” letter. It is recommended that the no conflict letter, marked plans, and a UAS allowing for attendance to the preconstruction meeting (1 to 2 days for attendance), be submitted through GUPS to document findings and protect the Utility’s and Department’s interest.
  
- c. **Utility Plan Development Submission Deadlines** - In accordance with O.C.G.A. § 32-6-171, the Department is required to set deadlines for Utilities to comply with information submittals in order for the Department to meet its project delivery schedule. It is the District Utilities Engineer’s responsibility to review each project within their jurisdiction and provide the Utilities with a deadline for each deliverable needed in accordance with the Department’s Plan Development Process (PDP) as well as the guidelines provided in this Manual.

If the Utility fails to submit to the Department the aforementioned information submittal by the deadline, the Department may no longer be required to reimburse the costs of removal, relocation, or adjustment required to accommodate the said project. Upon failure to meet the given deadline, the Utility will be notified by written notice by the District Utilities Engineer.

After the District Utilities Engineer reviews a project's schedule, written correspondence shall be sent to the affected Utilities on each project along with a deadline for the Utility to submit the required information to the Department. The deadline shall be no less than 30 days and no more than 120 days; and the deadline should be set based on the complexity of the project and the amount of review the Utility has to perform.

The written correspondence shall, among other instructions, contain in the subject or referenced line: "O.C.G.A. § 32-6-171 Request for Project information; GDOT Project Number and GDOT PI Number." The body of the letter shall contain the number of days the information is due back and the date that it is due back.

The following recommended information submittal deadlines are applicable for all "1st", "2nd" and "Revised Plan Submission" requests described above:

- 30 days for resurfacing projects; minor maintenance projects (drainage, shoulder work, vegetation)
- 60 days for intersection improvement projects (can vary based on number of intersections involved in the project); Intelligent Transportation Systems (ITS/ATMS) projects; Signal projects; enhancement type projects (sidewalks, bike paths, etc.); passing lane projects.
- 90 days for reconstruction and rehabilitation projects such as urban highway widening; widening to 4 lane divided highways; bridge projects; interchanges
- 120 days for mega projects (construction estimate over \$100 million dollars)

The deadline is subject to change based upon the Department's project schedule. It is the District Utilities Engineer's responsibility to track a project's schedule and notify the affected utilities if the deadline dates have changed.

- d. **Contents of Utility Plans** - For all projects with utility involvement, the Department's utility plans will show the approximate size, type and extent of existing utility facilities and proposed adjustments or relocations of utility facilities located within or near the project limits. Additionally, the utility plans will be presented in such a way as to clearly show how the utility

relocation work is to be performed in relation to the project's proposed overall staging and erosion control plans.

The Utility Plans when combined with the Utility Adjustment Schedule (UAS) provided to the Department by the Utility make up the Work Plan for each respective utility relocation/adjustment required for the project. These documents that make up the Work Plan need to be coordinated and sufficiently detailed to provide the Department and its Contractor a clear understanding of how the work will be performed in relation to the overall project's staged construction. Each Utility's Work Plan shall also be coordinated with the work of any other impacted utility facilities, such that no foreseeable conflicts are shown. This Work Plan is required to be submitted by each affected Utility and approved by the Department per O.C.G.A. § 32-6-171.

The Utility Plans shall show the following information as a minimum.

- **Design Details** - The location, length, size and/or capacity, type, class and pertinent operating conditions, and design features of existing, proposed, and temporary facilities, including proposed changes and disposition by appropriate annotation, symbols, legend, notes, color coding, etc.
- **Erosion & Sedimentation Control Best Management Practices (BMP's)** - The required erosion and sedimentation BMP's to address the utility construction that is not already addressed under the Department's erosion control plans
- **Relation to Project Features** - The project number, plan scale and date, horizontal and vertical location of utility facilities in relation to the alignment, geometric features, stationing, grades, structures, proposed and existing right-of-way lines, and, where applicable, the access control lines
- **Proposed Plan Notes or Special Provision** - When the Utility's work causes or requires coordination with other utilities, construction staging, or restrictive work periods or conditions
- **Summary of Quantities** - For utility work to be included in the Department's project contract to be included in the project pay items

- **Right-of-Way or Easement Requirements** - Where applicable, the limits of right-of-way to be acquired from, by or on behalf of the utility

**4.1.C.2. Determination of Method of Performance** - Upon completion of the utility plans and prior to certification or award of the project as required in Section 4.3 of this Manual, the Utility and the Department will complete arrangements as to the method of accomplishing the relocations or adjustments. The work may be accomplished by one or a combination of the following methods:

- The Utility with its own forces
- By a continuing Contractor who regularly performs similar work for the Utility.
- By the lowest qualified bidder after suitable advertisement by the Utility.
- By inclusion in the project's construction contract to be Let by the Department.

The contracting of reimbursable work by the Utility shall follow the requirements included in Section 4.2.D of this Manual and in 23 CFR 645, Subpart A, and shall be adhered to for all State projects regardless of funding source. If reimbursable by the Department, the method of accomplishing the work will be stated in the estimate supporting the agreement and written approval of the Department's State Utilities Engineer will be required for any change thereof.

**4.1.C.3. Policy on Including Utilities in Project Contracts** - In order to minimize construction coordination conflicts, utility adjustments should be included in the contract whenever feasible and when the Utilities are not equipped or staffed to perform the work. In general, adjustments to water and sewer facilities can be readily included in contracts, but any utility adjustment may be considered for inclusion if the situation on the project warrants such action. Determinations will be made on an individual project basis at the Preliminary Field Plan Review or shortly thereafter.

When it is determined that utility work is to be included in the highway contract, a clear definition of the requirements of the Utility for approval of the work, and of any materials and services to be provided by the Utility, will be included in a Memorandum of Understanding (MOU). Three counterparts of the form using an approved format with original signatures will be executed by the Utility and forwarded to the District Utilities Office along with the

marked utility plans when appropriate. The Department will review the proposed method of performance and, upon approval, execute and return an original counterpart of the Memorandum to the Utility. This Memorandum will subsequently serve as the basis for proceeding with inclusion of the work in the contract.

- 4.1.C.4. Work Plan Approval** - It is the responsibility of the District Utilities Engineer to review all Work Plans submitted by the Utility found within a project's limits. Please note that the District Utilities Engineer will typically consult with the District Construction Office and GDOT Project Manager to determine the reasonability of such Work Plans. If upon review, the District Utilities Engineer determines a Work Plan to be unreasonable based upon the required scope of utility adjustment and/or relocation required to accommodate a project; the District Utilities Engineer will initiate the following escalation process to resolve such disputes involving the Work Plan whenever they may occur.

The following is intended to outline an escalation process to which the Department and the Utility may follow to resolve any disputes regarding a Work Plan. If the dispute cannot be resolved within this escalation process, then such dispute will be brought forth to a mediation board hearing for resolution as prescribed in O.C.G.A. § 32-6-171 and GDOT Board Rule 672-19.

**Escalation Process Step 1** - After the District Utilities Engineer has reviewed and determined that the submitted Work Plan is unreasonable for the proposed utility work in question; the District Utilities Engineer will notify the Utility of such opinion through written correspondence. Such written correspondence shall detail the items in question and request the Utility to justify or revise the Work Plan accordingly. The Utility will respond to this letter within 10 business days. The response shall include justification or proposed revision to comply with the items in question identified by the District Utilities Engineer. In some cases the complexity of the Work Plan may require that a utility coordination meeting be held to address the issues identified by the District Utilities Engineer. If the Utility determines that this is the case, then the Utility's response letter shall include a request to hold a utility coordination meeting with the District Utilities Office for Work Plan resolution. If the Work Plan dispute cannot be resolved through the coordination efforts described above after 20 business days from the date provided in the District Utilities Engineer's original written



correspondence, the said dispute shall escalate to the State Utilities Engineer for further consideration (See Step 2 below).

**Escalation Process Step 2** - Upon written notification by the District Utilities Engineer, the State Utilities Engineer shall begin preparations and schedule a Project Utility Work Plan review meeting. Such meeting shall be held within 20 business days of the written notification referenced above. Attendees of this meeting shall include the following as a minimum:

- Utility Representative
- State Utilities Engineer (or designee)
- District Utilities Engineer (or designee)
- State Construction Engineer (or designee)
- Design Office Head Responsible for project (or designee).

In this meeting the attendees shall review the project's proposed design and staging plans in reference to the Utility's Work Plan under dispute. From this meeting a written conclusion/recommendation shall be produced to provide a course of action that will allow the project to move forward. One of the following written conclusions/recommendations shall result from this meeting:

- a. The Utility Work Plan is satisfactory as submitted – approved by the Department.
- b. The Utility Work Plan and/or Department staging plan require revisions to accommodate project construction. Such required revisions are subsequently approved and accepted by the Department and the Utility.
- c. Recommendation for Utility Work Plan dispute to proceed to Escalation Process Step 3 provided below.
- d. Recommendation for Utility Work Plan dispute to proceed to full Mediation as prescribed in O.C.G.A. § 32-6-171 and GDOT Board Rule 672-19.

**Escalation Process Step 3** – Once the determination is made from above to proceed with the escalation process, the Utility and the Department shall agree to participate in non-binding mediation or non-binding arbitration to aid in reaching a resolution. Further, the Department and the Utility shall equally share the costs and expenses associated with the mediation or arbitration. The

Department and the Utility shall agree on one mediator or arbitrator. The selected mediator or arbitrator shall meet the qualifications as prescribed in GDOT Board Rule 672-19. Within 10 business days after appointment of the mediator or arbitrator, the Department and the Utility shall agree on the rules for, and the scope of the mediation or arbitration. A mediation or arbitration meeting shall be held within 20 business days of the written notification referenced above. Upon completion of the mediation or arbitration meeting, a written conclusion/recommendation shall be produced to provide a course of action that will allow the project to move forward. One of the following written conclusions/recommendations shall result from this meeting:

- a. The utility Work Plan is satisfactory as submitted – approved by the Department.
- b. The utility Work Plan and/or Department staging plan require revisions to accommodate project construction. Such required revisions are subsequently approved and accepted by the Department and the Utility.
- c. Recommendation for Utility Work Plan Dispute to proceed to full Mediation as prescribed in O.C.G.A § 32-6-171 and GDOT Board Rule 672-19.

**4.1.C.5. Determination of Utility Right-of-Way and Easement** - The determination as to the need for replacement right-of-way or easement for utilities will be made as follows:

- a. The Department will determine what right-of-way is required for construction of the highway project and will normally provide adequate right-of-way for the existing or typical utility facilities that will be permitted to be accommodated within that right-of-way. The District Utilities Engineer will coordinate with each Utility to request any special right-of-way requirements necessary for their facilities.
- b. If there is not sufficient space for the utility within the right-of-way or easement which will be required for the construction of the project, the District Utilities Engineer will coordinate with the Utility to verify such circumstance and will obtain a written statement as to whether the Utility desires that the Department acquire such additional rights-of-way or easement as may be required for utility relocation under the provisions of the O.C.G.A. § 32-6-172. If the Utility insists on acquiring its own right-of-way or easement, the Utility shall notify the District Utilities Engineer in writing of such and shall include this

acquisition in the Work Plan referenced in Section 4.1 of this Manual.

Additionally, if the Utility intends to acquire its own right-of-way or easement, it shall be the District Utilities Engineer's responsibility to ensure that the Department's monthly Right-of-Way Status Acquisition Reports be forwarded to such Utility as received from the State Right-of-Way Office. These reports are critical to ensure that the Utility can begin acquiring their required right-of-way or easement soon after the Department has completed its negotiations with each affected property owner.

In either case, the following method of acquisition described in Section 4.1.C.6 (below) shall apply.

**4.1.C.6. Method of Acquisition** - It is desirable that replacement right-of-way and easements for utilities be acquired concurrently with acquisition of right-of-way for the highway project.

a. **Reimbursable Cases** - When the Utility is entitled to reimbursement for the cost of acquisition of replacement right-of-way or easements, the Department will request permission from the Utility, which must be obtained in writing, to acquire necessary utility right-of-way or easements concurrently with its acquisition of the normal highway right-of-way. If the Utility has some particular reason for insisting on acquiring the right-of-way or easement, this will be included in a Utility Agreement.

b. **Non-Reimbursable Cases** - If the cost of acquisition of replacement right-of-way or easement is not reimbursable, the Department will, at the written request of the Utility, acquire such right-of-way or easement under written agreement and the Utility will reimburse the Department for such cost in accordance with the State law. Any acquisition by the Department will comply with all requirements pertaining to the Department's acquisition of its own right-of-way or easement.

**4.1.C.7. Interest to be Acquired** - If the Utility agrees for the Department to acquire replacement right-of-way, property interest or easement, the Department's Office of Right-of-Way will determine what interest will be acquired and the instrument (i.e., quitclaim, easement limited agreement, etc.) to be used to transfer such interest from the Department to the Utility. The State Right-of-Way Engineer will notify the District Utilities Engineer and the State Utilities Engineer as to a determination regarding the Department's agreement to

acquire the right-of-way and of what interest is proposed to acquire. The District Utilities Engineer, in turn, will notify the Utility of that determination and will promptly notify the State Right-of-Way Office, with a copy to the State Utilities Engineer, of any exceptions the Utility may make to that determination. The State Utilities Engineer will be responsible for the establishment of Easement Limited Agreements (ELA) with the Utility after determination by the State Right-of-Way Engineer that such ELA is required to complete the rights of way acquisition. A copy of the ELA will be sent to the State Right-of-Way Office for legal recording.

## **4.2 REIMBURSEMENT FOR UTILITY RELOCATIONS & ADJUSTMENTS**

### **4.2.A. Conditions Governing Reimbursement -**

- 4.2.A.1. Participation in Utility Costs by Political Subdivisions -** Each municipality, county, authority or State agency will be required to adjust or relocate its facilities at its own expense unless their facilities hold a property interest. Utility-Aid may be approved, as authorized by O.C.G.A. § 32-6-170, in the case of an extreme hardship according to current guidelines (See policy 6863-11).

Local Governments who have entered into an agreement to sponsor a specific project will normally be responsible for funding the costs of removing, adjusting, and relocating those facilities which are physically in place and in conflict with proposed construction and, where replacement is necessary, for the costs of replacement in-kind for all Utilities deemed eligible for reimbursement under the reimbursement classifications identified in Section 4.2.A.2 of this Manual. Depending on the terms of the agreement, the Local Government may also be responsible for completing the arrangements (as set forth in this chapter) necessary to ensure all utility related project delays are avoided and that funding for reimbursement of relocations or adjustments will be secured prior to the project award. The determination of such responsibilities will be made by the Department's Office of Financial Management, usually in consultation with the Department's Project Manager. The project agreements between the Department and Local Government that establish the aforementioned responsibilities are typically executed prior to the project proceeding beyond the Planning/Concept Phase of project development. See GDOT policy 7120-3 for further

information regarding these Local government project specific agreements.

The responsibility for adjustments, surface upgrades or new protective devices required at railroad crossings will be the responsibility of the Department unless agreed otherwise in the project specific agreement referenced above. However, on projects funded through the Local Grants Office, the Local Government must bear these railroad costs.

On projects where the Local government is responsible for the costs and/or administrative duties referenced above and in Section 4.6 of this Manual, the Local Government shall provide written certification to the Department that satisfactory arrangements and agreements with each Utility have been completed prior to certification for advertisement of the project construction contract. Please see Section 4.6 of this Manual for further information regarding procedures to be followed on Local Government projects.

**4.2.A.2. Reimbursement Classifications** - Where the Utility is to be reimbursed for the cost of adjusting or relocating their facilities, such adjustments or relocations will be classified within the scope of Cases I thru X as follows:

**Case I** - This case applies when the Utility has right of occupancy in its existing location by reason of holding a fee, an easement or other property interest. The compensable interest in the lands they occupy can be defined and supported by a deed, written easement, or by other written evidence satisfactory to the Department in consultation with the State Law Department, to establish that a compensable property interest exists.

**Case II** - This case applies when any utility facilities owned by a municipality, county or authority, without regard to whether such facilities were originally installed upon the public right-of-way, where such relocation or adjustment is necessary to clear proposed work on the State Highway System. Reimbursement under this case requires approval of the Commissioner.

**Case III** - This case applies when any utility facilities owned by a municipality, county or authority which are installed within the right-of-way of a street or road under the jurisdiction of the same municipality or county prior to the time such street or road becomes a part of the State Highway System and which are subsequently

required to be relocated or adjusted for construction on the State Highway System or will become part of the permanent State Highway System upon completion of the construction project. In submitting claims for reimbursement under Case III, it will be necessary to furnish the date when the utility was installed and the date that the road or street became a part of the permanent State Highway System. Reimbursement under this case requires approval of the Commissioner.

**Case IV** - This case applies when it is determined to be in the public interest to install, adjust or occupy utility facilities so that the utility directly serves a transportation purpose and there will be costs to the Utility(ies) that will be incurred solely for this purpose. The cost of such installation or adjustment may be reimbursed under an agreement between the Department and the Utility. The agreement will cover the arrangements for new or replacement utility services to highway facilities such as welcome centers, rest areas, weigh stations, Department offices, or to support aerial or underground, traffic control devices, traffic signals, and/or sign installations (See Sections 4.7 and 4.8 of this Manual). When this Case is applied to Joint-Use Poles as described under Sections 4.7 and 4.8 of this Manual, reimbursement shall be limited to the pole owner only. This Case does not cover clearances required for project conflicts.

**Case V** - This case applies when a Utility relocates its facility to improve the safety of the roadside under a cost sharing agreement implemented specifically to address crash statistics. Projects shall be identified and programmed based on crash data and other traffic data to indicate there will be a high probability of measurable results benefiting the traveling public. Projects will normally require at least 50% participation from the utilities toward the in-kind replacement cost. Costs including right-of-way, engineering and administration of the in-kind relocation cost may be counted toward the Utility's share whether included in the agreement or a separate estimate to support the Utility's contribution to the project. The Utility may upgrade its facility in conjunction with the work but any costs attributable to the upgrade shall not be counted toward the minimum share to be borne by the Utility.

**Case VI** - This case applies when the advance installation of new utility facilities, crossing or otherwise occupying the proposed right-of-way of a future planned highway project, is either underway, or scheduled to be underway; prior to the time such right-of-way is purchased by or under control of the Department, arrangements shall

be made for such facilities to be installed in such a manner that will meet the requirements of the future planned highway project. Additional costs incurred by the Utility that are attributable to and in accommodation of the planned highway project and the proposed facilities, or portion thereof, will be outside the existing public road right-of-way, shall be eligible for reimbursement. For example, such additional costs may include the cost of providing higher poles or longer spans, encasement of cable or pipes, additional length of facilities and the like, that are needed to protect the planned highway and its safe operation, and which otherwise would not be required by the Utility for its own operation. However, if the Department has already acquired the right-of-way where the new installation is proposed, reimbursement will not apply and the installation will require a utility permit.

**Case VII** - This case applies when a Utility's facilities, in their existing locations, are found outside the public right-of-way and are in physical conflict with a given project in such a way as to require their relocation, adjustment, or replacement to accommodate a Department construction project. The said Utility will have thoroughly researched, or caused to be researched, its land records, GDOT electronic construction plan records, and available county/city records relating to the said location of the utility facilities and would be unable to find any supporting documentation to establish a property interest which describes the exact location of said utility facilities, nor has the Utility found any evidence of any party ever disputing Utility's property interest. Thus the Utility must submit an affidavit to establish that the Utility holds a property interest for the purposes of reimbursement for the engineering and construction costs, not to include replacement right of way and/or easement costs, associated with the referenced utility facilities. (See GDOT's Utilities webpages for DOT 8413M Property Interest Affidavit for Utility Facilities Located Off of Rights-of-Way.)

**Case VIII** - This case applies when it is determined to be in the public interest for the Department to pay the cost of removing relocating or making the adjustments to any utility facility owned by a public utility, without regard to whether such facilities were originally installed upon the right-of-way of the State Highway System, a county road system, or a municipal street system (See O.C.G.A. § 32-6-170). The following prerequisites must be satisfied before this case can be employed:

- a. It is determined by the Department that such reimbursement is necessary in order to expedite the staging of the project  
AND
- b. The costs of the removal, relocation, or adjustment of such utility facilities can be included as part of the contract between the Department and the Department's Contractor for the associated Department project.

Reimbursement under this case requires approval of the Commissioner.

**Case IX** - This case applies when a Utility relocates their facilities based upon final plans provided by the Department and is required to relocate, or adjust their facilities a subsequent time due to a design change that is determined to be no fault of the Utility (Note: Final plans are considered the plans issued to the Utility by the Department at the time of the Notice To Proceed or notice of Authorization). The eligibility of such claims for reimbursement will be considered by the Department on a case by case basis. Therefore, the additional expenses and circumstances must be documented and verifiable. Routine plan revisions are to be expected and will not normally justify reimbursement. This case applies to any utility facility, without regard to whether such facilities were originally considered reimbursable by any of the cases provided above.

**Case X** - This case applies when the Department determines that it is in the public interest to relocate existing overhead/aerial facilities to underground. A public interest determination might be justified from the standpoint of highway safety, aesthetics, economic development, community health, reduced network outages, scenic, environmental, historical and other such concerns as specified in Section 2.10 of this Manual. Reimbursement under this case requires approval of the Commissioner.

- 4.2.A.3. Non-Reimbursement Cases for Facilities in Conflict** - No Utility will be reimbursed for the cost of relocation or adjustment of utility facilities in conflict with project construction, maintenance and operations where the utility facilities were initially installed within the public right-of-way, except as provided under Cases II, III, IV, V, VIII, IX, or X.



## 4.2.B. Determination of Eligibility for Reimbursement -

**4.2.B.1. Certificate of Eligibility and Supporting Data** - Whenever a claim for reimbursement is made by a Utility, a Certificate of Eligibility for Utility Reimbursement must be completed. The Utility will complete those portions which identify the specific facilities for which the claim is made and the date and circumstances under which the facilities were installed. Upon review and verification of the information provided by the Utility, the Department will assign the Case Number (See 4.2.A.2) under which eligibility is established. This Certificate will be attached to and incorporated into the Utility Agreement executed for such reimbursement.

**4.2.B.2. Partial Eligibility** - When it is necessary to adjust a utility facility, a portion of which was originally installed within existing public road or street right-of-way, and a portion of which is located on private property required to accommodate the proposed highway construction, the cost of accomplishing such adjustment will be reimbursed on a percentage basis. An exception may be made when the reimbursable and non-reimbursable work can be readily separated for recordkeeping purposes or the reimbursable portion is reimbursed on a lump sum basis.

**4.2.B.3. Crossings** - As a general rule, the share paid by each party will be prorated by the location of the conflict. The facilities in conflict on private property will be paid by the Department and the facilities in conflict in the right-of-way will be paid by the Utility.

If additional vertical underground or overhead clearance or other protection not serving a highway purpose is required within the limits of the existing right-of-way, then such adjustment costs will be ineligible for reimbursement and will be prorated against the total estimated cost of the relocation or adjustment to accommodate the highway construction. For example, if existing poles must be replaced with taller poles, but no relocation is required, then no reimbursement would be due.

**4.2.B.4. Longitudinal** - Where a Utility to be relocated is installed generally along the existing right-of-way, but some segments are on private easement, the cost of adjustment may be prorated on the following basis. For underground facilities, such as pipelines or buried cable, the length of facility outside the right-of-way as a proportion of the total to be adjusted, measured in linear feet, may be used. For above-ground pole line facilities, the number of poles outside the

existing right-of-way as a proportion of the total to be relocated may be used.

**4.2.B.5. Other Methods** - In all cases the Utility may propose a method of prorating costs at the time a detailed estimate of reimbursable costs is prepared. Such proposal will be subject to review and approval by the Department. The Chief Engineer shall make a final determination of the appropriate ratio of costs to be borne by the Utility and the Department. The percentage to be borne by each party shall be included in the agreement required for the utility work and approved by the Department and the Utility.

**4.2.C. Eligible Costs to be Reimbursed** - When the adjustment or relocation of a utility installation is determined to be eligible for reimbursement, reimbursement may include the following:

1. Preliminary engineering expenses necessary to review and prepare plans, estimates, drawings, agreements, and work schedules prior to the time that construction is authorized. Preliminary engineering performed directly by the Utility (own employees) is eligible for reimbursement from the date the Utility is first requested to review project information; however, payment may not begin until a determination of eligibility for reimbursement is verified (i.e. property interest or as indicated in Cases I – X, etc.) and an agreement is executed and authorized between the Utility and Department. Where the Utility is not adequately staffed to review plans and prepare estimates as required by the Department, the Utility may be authorized to employ consultants to perform engineering services. Upon written approval, consultant expenses incurred after the approval date shall be eligible for reimbursement. (See Section 4.2.D of this Manual for procedures for approval of engineering services.) (See 23 CFR 172.)
2. Construction engineering for surveying and staking of the job site, inspection and supervision of the work and preparation of any plan changes or change orders which may be required. These services may also be provided by consultants as described above. Construction Engineering shall not be eligible for reimbursement when utility facility adjustment/relocation work is included in the Department's project contract. When relocations or adjustments are included in the Department's project contract, such services will be performed by the Department's Project Engineer. The Department's Project shall inform the Utility of any changes in an effort to gain their concurrence.
3. Costs of direct labor, materials, supplies, and equipment required to complete the adjustment or relocation, less salvage credit for any materials

removed from the project and credits for any betterment not required by the highway project. The work may be accomplished with the Utility's own forces, or by contract upon prior Department approval of the Utility's continuing contract with a contractor or bid tabulations from a Utility's competitive bid for such work. (Requirements and procedures for approval of contractors are contained in Section 4.2.D of this Manual.)

4. Construction related overhead costs which can be shown by the records of the Utility to be reasonably associated with the project and in accord with Generally Accepted Accounting Principles (GAAP), and its standard accounting procedures and practice for assigning overhead expenses to other similar work which the utility undertakes. Overhead rates must be supported by internal or external audits acceptable to the Department. Only those overhead costs which are necessary for the performance of the adjustment are eligible for reimbursement.
5. Right-of-way costs for replacement right-of-way or easements necessary to relocate the utility when such right-of-way is acquired in conformance with the Department's acquisition procedures:
  - a. The Department acquires the necessary right-of-way on all projects subject to any easement rights for the installation, operation and maintenance of utility facilities which may be outstanding. If the utility facilities installed under authority of such prior easement rights do not physically conflict with the proposed highway work, an Easement Limited Agreement will be executed to provide for the Department's encroachment over the easement of the Utility; preserve the Utility's current and future reimbursement rights for the original facilities; and require the Utility's facilities to meet the requirements set forth in this Manual. Original facilities mean facilities consistent with the original easement rights.
  - b. Where existing utility facilities were initially installed under prior utility right-of-way or easement rights, and such facilities are adjusted within the limits of the right-of-way after/or later acquired by the Department, then the existing prior easement rights would be transferred to the new location of such adjusted utility facilities, except that future operation and maintenance of the facilities, or installation of any new facilities will be subject to the Department's Manual. This does not extinguish the Utility's rights, and if it becomes necessary to adjust the original facilities on future highway work, then the cost of the subject adjustment may be eligible for reimbursement on the basis of those rights and the circumstances which may then exist. Original facilities mean facilities consistent with the original easement rights.
  - c. Where buildings and other improvements are demolished or removed from the project's required right-of-way by the owner of the structure involved, by the city or county under contract with an independent

contractor, or by the Department, the removal or demolition shall include the cost of removing, replacing and/or adjusting utility services, such as water, sewer, electrical power, telephone, and gas service connections to accommodate the proposed highway construction. The estimate furnished by the Utility in connection with the adjustment of utility facilities shall not include the cost of changes in service connections when structures are to be moved as a part of the right-of-way acquisition. Where demolition of structures is Let to contract, the bid price for demolition shall include the cost of service lines at a point established by the Utility.

#### **4.2.D. Reimbursement of Consultant and Contractor Services -**

When a Utility is not adequately staffed to perform engineering and/or construction with its own forces, it shall notify the Department's District Utilities Engineer and the use of consultants and/or contractors may be permitted in accordance with 23 CFR 645.109 and 23 CFR 172. The following procedures shall apply:

##### **4.2.D.1. Consultant Services**

**4.2.D.1.a. Selection of Consultant** - The Utility will select and secure proposals from qualified firms who perform work for the Utility or who have otherwise demonstrated ability to perform the required services. The consultant's past performance to meet the Department's schedule and standards will be a consideration for Department approval of the consultant for use on Department projects on a continuing basis.

The Department has adopted 23 CFR as the guide for procurement of services without regard to the source or funds. As far as practical, the Utility shall satisfy the requirements of 23 CFR. Participation by the Department will be on a reimbursement basis; therefore, the Utility is responsible for establishing a written agreement with the Consultant and for any payments required.

**4.2.D.1.b. Proposal Requirements** - Proposals will be prepared in accordance with the following:

- The proposal will contain a brief but concise scope of the services, including a detailed list of deliverables and schedule milestone completion dates, to be performed with sufficient description of each service so that the scope of the work is clear.
- The proposal will contain a schedule of bare labor costs, direct expenses, fee (profit) and overhead (indirect costs). Labor costs shall be itemized for each employee classification which is expected to be used in the work, including administrative and clerical personnel whose time may be charged directly to any work for the Utility. Accounting system verification may be required for agreements over \$50,000. A prior audit may be required for agreements over \$100,000 to verify rates and accounting methods at the Department's discretion. Services for preliminary engineering and construction engineering must be itemized separately in an approved format (see Section 4.2.E of this Manual).
- If the proposal is to cover services to be provided on a continuing basis, the proposal shall reference and reflect the continuing contract, effective period and rates. These will be included in individual project estimates. The Utility shall provide evidence that a continuing contract exists between the Utility and its Consultant and provide a copy for the purpose of audits if requested.
- The proposal will further stipulate that all project charges will be supported by the consultant's records and that such records will be made available at the principal place of business and be subject to audit by the Department, and by the FHWA, if appropriate, during the life of the project and for a period of at least 3 years after final payment has been received by the Utility.

**4.2.D.1.c. Department Approval** - The Department's approval of a consultant's proposal and rates will constitute authority for the Utility to employ that consultant to perform engineering services in connection with design and construction of utility relocations and adjustments to

accommodate highway construction. The following procedures shall apply to Department Approval:

- Upon submission to the Department's District Utilities Engineer of consultant job classifications and rates, approval may be given for use of a consultant on a continuing basis, as long as the charges by the consultant on any given project do not exceed \$25,000 or 10% of the construction relocation estimate, and provided the approved schedule of rates does not change. Whenever it appears that the preliminary engineering (design) charges on a project will exceed \$25,000 or 10% of the construction relocation estimate, the Utility shall obtain prior approval of the Department before having the consultant proceed with further work. Any expenditure in excess of approved limits will be subject to audit citation and disallowance for reimbursement. The Department's written notice to review and mark existing or relocated facilities shall serve as the date preliminary engineering is authorized subject to the above eligibility verification.
- When consultants are not used on a continuing basis by a Utility, approvals of proposals are required on an individual project basis and will specify the maximum amount to be paid. The approved amount may be exceeded only upon prior approval of the Department.

**4.2.D.1.d. Certification of Consultant** - A Certification of Consultant must be completed and furnished with the Consultant's proposal before approval can be given. The Certification confirms that there is no collusion and verifies the existence of a contract with the Utility.

#### **4.2.D.2. Contractor Services for Utility Construction**

**4.2.D.2.a. Solicitation or Advertisement of Bids** - When reimbursement is to be requested, any contract to perform work in connection with the utility construction shall be under an award to the lowest qualified bidder who submits a proposal in conformity with the requirements and specifications of the work to be performed after an appropriate solicitation for bid. The District Utilities

Engineer shall be notified of the date and time for the bid opening. The Utility shall submit the bid tabulations to the District Utilities Engineer and obtain the Department's concurrence prior to award of the contract proposal. If concurrence is not obtained prior to award, the Department may require the Utility to re-advertise the bid solicitation. Project delays resulting from non-conformance of this requirement shall be documented by the Department and shall follow the procedures provided in Section 4.4.C of this Manual.

**4.2.D.2.b. Continuing Contracts** - An exception to the bid requirement may be made for work to be performed under an existing, written, continuing contract where it is demonstrated that such work is regularly performed for the Utility under such contract at reasonable costs. Information regarding terms of the contract must be submitted to the District Utilities Engineer for review before approval will be given for its use in reimbursable work on highway projects. The Utility's estimate shall reference and reflect the continuing contract, effective period and rates. The Utility shall provide a copy for the purpose of audits or rate verification if requested.

## **4.2.E. Preparation of Cost Estimates -**

### **4.2.E.1. Estimate Requirements -**

**4.2.E.1.a. Itemized Detail, Actual Cost, or Lump Sum** - Cost estimates for relocation or adjustment of those utilities determined eligible for reimbursement shall be prepared by the Utility in accordance with the provisions in 23 CFR 645 and as shown and explained in "Suggested Guideline for Preparation Of Detailed Estimate to Support Utility Relocation Agreement" and "Consultant Engineering Fee Guidelines" on the GDOT Utilities webpages. Except where unit costs are used and approved, the estimate shall show details such as personnel hours by class and rate, equipment charges by type, size and rate, materials and supplies by item and price, and payroll additives and other overhead factors, with a statement of what is included in each, and the basis for determining the percentages used. In addition,

the estimate shall show the items of work to be performed, including preliminary engineering and construction engineering, right-of-way, and an itemization of credits for salvage and betterments in sufficient detail to provide a basis for analysis by the Department. Material allowances may be paid if identified in the estimate, and if meeting the requirements in the Department's Standard Specifications, current edition, for material allowances. The estimate shall be supplied in the Department's required format on forms provided by the Department or in an approved format using forms supplied by the Utility. For Utilities unfamiliar with the Department's reimbursement procedures, the District Utilities Engineer may assist with entering cost information in an acceptable format.

**4.2.E.1.b. Additional Requirements for Lump Sum Estimates -**

When requested by the Department, the Utility shall provide history of costs for similar work performed on an actual cost or low bid basis as well as current quotes from contractors and suppliers. This is in addition to the itemized detail required for estimates, so the Department may determine if the proposed lump sum payment is reasonable. The estimate shall be adjusted for differences between the example projects and the project so that the final estimate to be used for the agreement will be near the midrange of expected costs; therefore, the risk associated with the lump sum method of estimating accuracy shall be equally divided between the Department and Utility. Upon prior approval, significant changes in the scope of work after the agreement is established may require a change in the agreement or a new agreement as described in Section 4.2.F.5 of this Manual.

**4.2.E.1.c. Work by Consultants -**

The estimate will state when a consultant is to be used for preliminary engineering and/or construction engineering. Prior written approval by the State will be required and a Certification of Consultant, as required and referenced in Section 4.2.D of this Manual, must be included along with the scope of work and estimate unless previously furnished with the Consultant's proposal. Engineering work to be performed by a consultant must be separately identified in the



estimate as referenced in Section 4.2.E.1.a of this Manual.

**4.2.E.1.d. Work by Contract** - Any construction work to be performed by contract (as referenced in Section 4.2.D of this Manual) must be separately identified in the cost estimate. If any work is to be performed by third parties, except as shown in the approved cost estimate, the Utility shall obtain Department approval prior to performing any contract work.

**4.2.E.1.e. Certificate of Eligibility** - A Certificate of Eligibility for Utility Reimbursement (see Section 4.2.B.1 of this Manual) shall be completed by the Utility and attached to the cost estimate.

**4.2.E.2. Estimate Submittal Deadlines** - As provided in Section 4.1.C.1.b of this Manual, estimates required for reimbursable Utilities are typically to be included with the “2nd Submission” information request. The Utility shall provide the information specifically requested for each submittal request letter sent by the District Utilities Engineer (see Section 4.1.C.1.c of this Manual). The deadlines referenced for these requests will therefore apply for the estimates submitted also.

**4.2.E.3. Review by Department** - The plans, specifications, and estimate package will be reviewed by the District Utilities Engineer to ensure the said package meets the requirements referenced above and is reasonable for the scope of work proposed by the Utility to accommodate the project. After this review, the District Utilities Engineer will then forward the plans, specifications, and estimate package along with a written recommendation to State Utilities Engineer for preparation of the Utility Agreement. The Project Manager responsible for project plans may also be consulted to ensure estimate reasonability prior to preparation of the Agreement by the State Utilities Engineer.

## **4.2.F. Agreements -**

**4.2.F.1. Requirements of Agreements** - When agreements are required under the provisions of Section 4.0.A.3 of this Manual, the State Utilities Engineer will be responsible for their preparation. Where reimbursement is to be made for a utility relocation or adjustment,

the Agreement must be executed by the Utility and the Department and written authorization be given to the Utility prior to any payment. The Agreement amount will be the estimated cost to the Utility to complete the relocation or adjustment. The basis of payment will be actual costs to complete the work; except when the relocation work can be clearly and concisely defined and the reimbursable cost can be accurately estimated, a lump sum agreement and payment may be approved. In either case, the agreement shall be supported by a detailed estimate as described in Section 4.2.E of this Manual and by plans as described in Section 4.1 of this Manual.

- 4.2.F.2. Preparation of Agreements** - After the review referenced above in Section 4.2.E.2 of this Manual, the District Utilities Engineer will send the detailed estimate with a letter of recommendation, plans, estimate checklist, and other supporting information required covering the adjustment of existing utility facilities in conflict with highway construction to the State Utilities Engineer. The State Utilities Office will prepare the agreement and coordinate approval and execution. If requested by the State Utilities Office, the District will follow up to ensure timely return of the agreement after it is sent to the utility.

All agreements shall be in writing and shall be executed in one of the Department's approved forms as described below:

- **Standard Utility Agreement (SUA)** - An Agreement providing for relocation or adjustment work to be performed by the Utility and/or its consultant or contractor and modification of easement limited provisions (See Section 4.1.C.5 of this Manual), if applicable. To the extent practical, reimbursement by the Department will be made based upon the Department's specifications, agreements and forms for consultant and construction contract work. The payment method may be actual cost, unit price, or lump sum, as appropriate (see Section 4.2.E of this Manual).
- **Contract Item Agreement (CIA)** - Used for including utility work in the Department's project and performed by the Department's Contractor awarded by competitive bid. Any utility system upgrades, betterments, or non-reimbursable relocations (not covered in the Cases specified in Section 4.2.A.2 of this Manual) to be installed in the Department's project shall require reimbursement to the Department from the Utility.

- **Easement Limited Agreement (ELA)** - Used to document and preserve the existing reimbursement rights of the Utility for future projects and modifying the Utility's right-of-way or easement right to the extent that all future installation, operation and maintenance of the Utility's facilities within the highway right-of-way shall be in accordance with this Manual, current edition.
- **Transportation Purpose Agreement (TPA)** - Used when the Department as part of a project proposes to install traffic signals, signs, or other traffic control devices on or within a utility facility, or requires a utility to service a highway facility, and such installations will require modifications to or the addition of new utility facilities. Such modifications or new utility installations will be reimbursed by the Department, through this type of agreement. See Section 4.8 of this Manual for all applicable provisions that will be required.

**4.2.F.3. Departmental Reviews and Approval** - Agreements will be approved and executed by the Deputy Commissioner or Commissioner. When deemed appropriate, the prior concurrence of the State Right-of-Way Engineer, the State Traffic Operations Office, the Office of Audits, and/or the Attorney General of Georgia may also be required. It will be the responsibility of the State Utilities Engineer to obtain these required recommendations and present them to the Deputy Commissioner or Commissioner, along with the Agreement, for approval before execution on behalf of the Department.

**4.2.F.4. FHWA Approval** - The State Utilities Engineer will certify to the Commissioner that agreements are in accordance with policy, State and Federal laws or requirements, and will obtain Federal Highway Administration (FHWA) approval when required. In the event the Federal Highway Administration questions any portion of the utility plans, estimate or agreement, the State Utilities Engineer will coordinate with the appropriate design office or District Engineer to resolve any differences and obtain Federal Highway Administration approval, or recommend other appropriate action to the Commissioner.

**4.2.F.5. Agreement Change Orders, Modifications, Allotment Requests** - Any time during the course of the preliminary engineering, or physical relocation or adjustment work, when it becomes apparent that substantial (typically greater than 10%) change in plans or quantities will be required, or that the actual cost of the work will

exceed the amount of the agreement, a written change order, allotment request and/or supplemental agreement for additional funds will be prepared by the Department and executed by both parties, if necessary.

**4.2.F.5.a. Utility Responsibility** - The Utility is responsible for notifying the Department prior to proceeding with any change that will cause an increase in cost of the work covered in the utility agreement. For changes in Engineering performed during the preconstruction phase of a project; the Utility shall contact the Department's District Utilities Engineer responsible for written approval to proceed. For construction related costs, the Utility shall contact the Department's Area Engineer to obtain verbal approval prior to proceeding with any change that will cause an increase in cost of reimbursable work. Such verbal notification must be followed up in writing within 30 days. Failure to provide notification may result in the Department disallowing reimbursement for the expenses if verification cannot be independently made by the Department.

**4.2.F.5.b. Department Responsibility** - The Department shall be responsible for processing a change order, modification, allotment request, and/or Supplemental Agreement, if required, to cover any changes in the work. Verbal approval of changes will be followed up in writing within 30 days of the Utility's written request. The Department's Area Engineer shall document changes, recommend approval and secure concurrence through the District and State Utilities Offices. Minor changes (cumulative less than 10% of the total agreement amount) may be approved at the Area level so that the work will not be delayed and followed up in writing as stated above.

### **4.3 AUTHORIZATION & CERTIFICATION PHASE**

#### **4.3.A. Authorization To Incur Costs -**

**4.3.A.1. Requirement for Written Authorization** - Payment will not be made to any Utility for any work or expenses incurred prior to

written authorization from the State Utilities Office to proceed. For preliminary engineering, this authorization will be included in the request for plans and estimates. Construction authorization will normally be given after the Utility Agreement has been fully executed and after the highway contract is awarded. For work which can be accomplished in advance of highway construction, authorization will be given as soon as the agreement is executed by both the Utility and the Department, funds have been allotted, and a date is established for the highway contract letting. Additionally, right-of-way/environmental clearances are required to be granted for the areas where the reimbursable utility work is proposed. Such clearances must be obtained from the Department's State Environmental Engineer and State Right-of-Way Administrator. Where the utility work is contingent on work by the highway Contractor, authorization will be withheld until the highway contract is awarded. When necessary to expedite utility relocations and avoid interference with highway construction, early authorization or conditional authorization may be given provided the project's utility funding is established. Unconditional authorization must be received by the Utility prior to billing for reimbursement.

- 4.3.A.2. FHWA Approval** - Federal Highway Administration approval of plans, estimates, agreements and authorization will be required on those classes of federal-aid projects for which the State's certification acceptance procedures have not been approved or do not apply.

## **4.4 CONSTRUCTION PHASE**

### **4.4.A. Construction Notification And Coordination -**

- 4.4.A.1. Notice of Project Contract Advertisement** - All Utilities having known facilities in conflict with the project limits will be notified by the District Utilities Engineer, when the construction project is advertised for bids and directed to proceed with any necessary relocation or adjustment of their facilities to clear the construction project. If work is covered by agreement and separate authorization, this notice will serve as advance notification of the advertisement so the Utility may anticipate the need to begin procuring contracts, materials, etc. as authorized in Section 4.3.A of this Manual.

- 4.4.A.2. Notice of Project Contract Award** - A reminder notification for non-reimbursable Utility work will also be given to the utilities by the State Utilities Office when the project contract is awarded. This second notice (Notice of Award) will give the Utility the highway Contractor's name and the Department's Area Engineer responsible for the project and re-emphasize the need to complete utility adjustments or relocations. Provisions for coordination and cooperation between the Utility and the highway Contractor are included in the Department's Standard Specifications, current edition, in Articles 105.06 and 107.21. In addition, special provisions for coordination may be included in the highway contract. Note: Reimbursable work covered by agreement is authorized before or after award as stated in Section 4.3.A of this Manual.
- 4.4.A.3. Preconstruction Conference** - It is the practice of the Department to conduct a preconstruction conference on most projects with the Contractor prior to the beginning of construction. The Utility will be notified via electronic mail of this conference by the Department's District Utilities Office. The Utility is expected to have a representative in attendance. If the facilities in question are reimbursable, the expense of attendance may be billed as preliminary engineering if utility construction work has not been authorized, or as construction engineering if construction work has been authorized. (The cutoff between Preliminary Engineering charges and Construction Engineering charges will be the date of the Authorization of the Utility Agreement from the State Utilities Office). In all cases the Utility shall cooperate fully with the Department and the highway Contractor to minimize conflict(s) with highway construction.
- 4.4.A.4. Notice to Department by Utility** - The Utility shall notify the Area Engineer prior to beginning any construction activities, when work will be suspended and prior to resuming work if construction activities are not continuous. Failure to notify the Area Engineer will jeopardize payment on reimbursable work since any work performed without notification and cannot be verified may be cited and deducted from a progress or final bill. The Area Engineer will notify the State Utilities Engineer and the District Utilities Engineer of beginning and ending dates of work by the Utility. Also, failure to properly locate facilities in reference to alignment and grade for the project as established by the Department may result in having to move facilities a second time at the Utility's expense.

**4.4.A.5. Traffic Control** - Prior to commencing work associated with highway construction, whether by permit or agreement, the Utility shall conform with the requirements of Section 2.9 and Section 3.7 of this Manual; except that prior to beginning any work the Utility shall notify the Department's Area Engineer or Project Engineer and present their work schedule and temporary Traffic Control Plan in order to review for any changes from the preconstruction phase submittal and for understanding by all parties prior to occupying the work site.

**4.4.B. Revised Work Plan Approval** - If previously unforeseen utility removal, relocation, or adjustment work is found necessary by the Department, the Utility or the Department's Contractor after the letting of a project, the Utility shall provide a revised Work Plan within 30 calendar days after becoming aware of such work or upon receipt of the Department's written notification advising of such work. The incorporation of this revised Work Plan into the overall project schedule is not intended to correct errors and omissions with the original or current approved Work Plan submitted to the Department. If such errors or omissions occur, it will be the Utility's responsibility to adhere to the original or current Work Plan submitted and approved. However, when it is deemed appropriate for a revised Work Plan to be submitted, the following procedure shall be followed for its approval:

It is the responsibility of the District Utilities Engineer to review all revised Work Plans submitted by the Utility found within a project's limits. Please note that the District Utilities Engineer will typically consult with the District Construction Office and GDOT Project Manager to determine the reasonability of such revised Work Plans. Additionally, the Department's Contractor will also be consulted. If, upon review, the District Utilities Engineer determines a revised Work Plan to be unreasonable based upon the required scope of utility adjustment and/or relocation required to accommodate a project, the District Utilities Engineer will initiate the following escalation process to resolve such disputes involving the revised Work Plan whenever they may occur.

The following is intended to outline an escalation process to which the Department and the Utility may follow to resolve any disputes regarding a revised Work Plan. If the dispute cannot be resolved within this escalation process, then such dispute will be brought forth to a mediation board hearing for resolution as prescribed in O.C.G.A. § 32-6-171 and GDOT Board Rule 672-19. During the escalation process or mediation process, the contractor and utility will continue to pursue work in accordance with the existing Work Plan.

**Escalation Process Step 1** - After the District Utilities Engineer has reviewed and determined that the submitted revised Work Plan is unreasonable for the additional utility work in question, the District Utilities Engineer will notify the Utility of such opinion through written correspondence. Such written correspondence shall detail the items in question and request the Utility to justify or change the revised Work Plan accordingly. The Utility will respond to this letter within 10 business days. The response shall include justification or proposed revision to comply with the items in question identified by the District Utilities Engineer. In some cases the complexity of the revised Work Plan may require that a utility coordination meeting be held to address the issues identified by the District Utilities Engineer. If the Utility determines that this is the case, then the Utility's response letter shall include a request to hold a utility coordination meeting with the District Utilities Office for revised Work Plan resolution. If the revised Work Plan dispute cannot be resolved through the coordination efforts described above, after 20 business days from the date provided in the District Utilities Engineer's original written correspondence, the said dispute shall escalate to the State Utilities Engineer for further consideration (see Step 2 below).

**Escalation Process Step 2** - Upon written notification by the District Utilities Engineer, the State Utilities Engineer shall begin preparations and schedule a Project Utility Work Plan review meeting. Such meeting shall be held within 20 business days of the written notification referenced above. Attendees of this meeting shall include the following as a minimum:

- The Utility Representative
- Department's Contractor
- State Utilities Engineer (or designee)
- District Utilities Engineer (or designee)
- State Construction Engineer (or designee)
- Design Office Head Responsible for project (or designee).

In this meeting, the attendees shall review the project's proposed design and staging plans in reference to the Utilities revised Work Plan under dispute. From this meeting, a written conclusion/recommendation shall be produced to provide a course of action that will allow the project to move forward. One of the following written conclusions/recommendations shall result from this meeting:

1. The revised Utility Work Plan is satisfactory as submitted – approved by the Department.



2. The revised Utility Work Plan and/or Department staging plan need further revisions to accommodate project construction. Such required revisions are approved and accepted by the Department and the Utility.
3. Recommendation for revised Utility Work Plan dispute to proceed to Escalation Step 3 noted below.
4. Recommendation for Utility Work Plan dispute to proceed to full Mediation as prescribed in O.C.G.A. § 32-6-171 and GDOT Board Rule 672-19.

**Escalation Process Step 3** - Once the determination is made from above to proceed with the escalation process, the Utility, the Department's Contractor, and the Department shall agree to participate in non-binding mediation or arbitration, to aid in reaching a resolution. Further, the Department and the Utility shall equally share the costs and expenses associated with the mediation or arbitration. The Department and the Utility shall agree on one mediator or arbitrator. The selected mediator or arbitrator shall meet the qualifications as prescribed in GDOT Board Rule 672-19. Within 10 business days after appointment of the mediator or arbitrator, the Department and the Utility shall agree on the rules for and the scope of the mediation or arbitration. A mediation or arbitration meeting shall be held within 20 business days of the written notification referenced above. Upon completion of the mediation or arbitration meeting, a written conclusion/recommendation shall be produced to provide a course of action that will allow the project to move forward. One of the following written conclusions/recommendations shall result from this meeting:

1. Revised utility Work Plan is satisfactory as submitted – approved by the Department.
2. Revised utility Work Plan and/or Department staging plan revisions are necessary to accommodate project construction. Such required revisions are approved and accepted by the Department and the Utility.
3. Recommendation for revised Utility Work Plan dispute to proceed to full Mediation as prescribed in O.C.G.A. § 32-6-171 and GDOT Board Rule 672-19.

**4.4.C. Procedures for Utility Damages or Delay Costs** - If the Utility fails to provide a Work Plan or fails to complete the removal, relocation, or adjustment of its facilities in accordance with the Work Plan or Revised Work Plan approved by the Department, then the Utility may be liable to the Department or its Contractor for delay costs and damages incurred by the Department or its Contractor which grow out of the failure of the Utility to carry out and complete its work accordingly. However, the following escalation process shall be utilized by the Department, its Contractor, and the

Utility to resolve such disputes regarding damages or delays prior to requests for payment or such claims being brought forth to a mediation board hearing for resolution as prescribed in O.C.G.A. § 32-6-171 and GDOT Board Rule 672-19.

**Escalation Process Step 1** - It shall be the Contractor's responsibility to coordinate and track each Utilities progress in relation to the Work Plan or Revised Work Plan previously approved by the Department. Once the Contractor has determined that the Utilities work progress is at least 20% behind the approved Work Plan, it will be the Contractor's responsibility to notify the Utility and the Department of such apparent delay through written correspondence. If such notification is not timely performed, then said time between the stated 20% behind noted previously and the actual date that the Utility and the Department receives written correspondence of such apparent delay shall not be considered as part of the Contractor's request for delay. Such written correspondence shall detail the delay in question and request the Utility to submit a proposal on how the Utility plans to rectify such delay and maintain the project's schedule prescribed by the previously approved Work Plan. The Utility will respond to this letter within 10 business days. The response shall include a proposal to cure the delay identified by the Department's Contractor. In some cases, the complexity of the project may require that a utility coordination meeting be held to address the issues identified by the Department's Contractor. If the Utility determines that this is the case, then the Utility's response letter shall include a request to hold a utility coordination meeting with the Department's Contractor, the District Construction Engineer, and, the District Utilities Engineer for utility delay resolution. If any changes are made to the Utility's Work Plan, such revisions shall adhere to Section 4.4.B. If the utility delay dispute cannot be resolved through the coordination efforts described above after 20 business days from the date provided in the Contractor's original written correspondence; the said dispute shall escalate to the State Construction Engineer for further consideration (See Step 2 below and GDOT's Utilities webpages for the Utility Escalation Process Guidelines & Responsibilities).

If, during utility and construction coordination efforts, changes are made to the Utility's Work Plan, whether written or verbal, such changes shall be documented by the Utility and added to the Utility's Work Plan. In its tracking efforts, the Contractor shall consider such changes when establishing the Utility's progress.

**Escalation Process Step 2** - Upon written notification by the District Construction Engineer, the State Construction Engineer shall begin preparations and schedule a Project Utility Delay Mitigation meeting. Such meeting shall be held within 20 business days of the written notification

referenced above during this Step of the escalation process. Attendees of this meeting shall include the following, as a minimum:

- The Utility Representative
- Department's Contractor
- State Utilities Engineer (or designee)
- District Utilities Engineer (or designee)
- State Construction Engineer (or designee).

In this meeting, the attendees shall review the project's proposed design/staging plans and the Utility's Work Plan in relation to the project's and the Utility's current construction status. From this meeting, a written conclusion/recommendation shall be produced to provide a course of action that will allow the project to move forward. One of the following written conclusions/recommendations shall result from this meeting:

1. The Utility's proposal to cure the utility delay is satisfactory for the completion of the project on schedule. Recommendation to proceed with the project given the Utility's proposal with no claim being raised against the Utility.
2. The Utility's proposal to cure the utility delay is not satisfactory for the completion of the project on schedule, and the Utility may be liable for damages or delay costs. The utility delay cost/damage claim dispute shall be resolved through payment or Mediation as prescribed in O.C.G.A. § 32-6-171 and GDOT Board Rule 672-19. The Department or its Contractor shall notify the Utility in writing (by certified mail or statutory overnight delivery, return receipt requested) that the utility is liable for such damages or delay costs. Such written correspondence shall only be sent after the Utility has completed the related utility facility relocation or adjustment work to which the damage claim is based upon and within 30 calendar days after the project contract time expires, including any project contract time extension(s) granted by the Department. Further, this letter shall also detail the claim for damages and itemize the associated costs respectively. The following items only may be recoverable by the Contractor as damages:
  - a) Additional direct hourly rates paid to employees for job site labor, including payroll taxes, welfare, insurance, benefits and all other labor burdens.
  - b) Documented additional costs for materials.
  - c) Documented additional equipment costs.
  - d) Documented costs of extended job-site overhead (only applicable to a delay claim).

- e) Additional 15 percent of the total of above items: a, b, c and d, which sum includes home office overhead and profit.
- f) Required Bond costs.
- g) Subcontractors cost in accordance with above items a, b, c, d, e, and f.

The Utility shall have 45 calendar days from receipt of such letter to either pay the amount of the damages or delay costs to the Department or its Contractor or request a Petition for Mediation Board Hearing as prescribed in O.C.G.A. § 32-6-171 and GDOT Board Rule 672-19. To request a Petition for Mediation the Utility shall submit the Uniform Petition for Mediation form (see GDOT's Utilities webpages) and any associated information to each Party involved in the dispute in accordance with GDOT Board Rule 672-19-.06 Mediation Board Procedures.

## **4.5 BILLING & PAYMENT PHASE**

### **4.5.A. Basis of Reimbursement -**

**4.5.A.1. Reimbursement to Represent Actual Costs** - It is the intent of the Department that Utilities be reimbursed for actual costs incurred for the items, specified in Section 4.2.C of this Manual, in connection with any utility relocation or adjustment. Such costs shall be supported by adequate accounting records in the Utility's files and shall be subject to audit by the State, and the Federal Highway Administration (FHWA) when federal funds are involved for a period of 3 years from the date the final payment has been received by the utility (23 CFR 645.117i). Guidelines for determining actual eligible costs shall be those contained in 23 CFR 645, Subpart A. The Department's form (currently 8465) has been adopted for this purpose, a copy of which is available on GDOT's Utilities webpages or can be provided by the Department's District Utilities Engineer.

**4.5.A.2. Basis of Payment** - As discussed in Section 4.2.E of this Manual, on projects where the estimated total cost of the work can be clearly and concisely defined and can be accurately estimated, a lump sum payment may be agreed to. The amount of any lump sum payment shall be based on a detailed estimate.

On all other projects final payment shall not be made until the Utility has presented a bill covering in detail the actual costs under the agreement and such bill has been verified by the Department. The

final payment will be made conditional subject to audit findings. Once the conditional payment has been made, no further payment will be made or refund made to either party except required by audit findings.

**4.5.B. Progress Bills** - Periodic progress bills, if provided for in the Agreement shall be submitted to the State Utilities Engineer.

**4.5.B.1. Frequency** - Generally, the Utility may submit progress bills once per month in amounts greater than \$1,000.

**4.5.B.2. Method of Billing** - All progress bills must provide a summary of charges listing the totals for each category and actual total of all material installed to date. Progress bills reflecting a total billed to date of 80% of the authorized agreement amount or higher, including any approved allotment requests, must be itemized with attachment of all supporting information. As a supplement to the CFR, “Reimbursement Guidelines and Billing Procedures for Utility Adjustments” is available as a reference. (See GDOT’s Utilities webpages.)

**4.5.B.3. Payment** - Properly itemized progress bills shall be paid in full promptly upon verification. For progress bills not itemized, any questioned cost may be deducted from the bill until sufficient itemization for the charge is received and verified. Utilities covered by multi-state or approved Audit procedures (in consultation with the State Audits Office) may be paid based on a summary statement up to the agreement amount. All bills exceeding the agreement amount or final bills must be itemized. If bill is incorrect or incomplete, then it will be returned to the biller for correction.

**4.5.C. Final Bills** - The final billing by the Utility shall be complete including a detailed summary of all expenses incurred in the relocation. Such final bills must follow closely to the detailed estimate supporting the Agreement as to items of labor, equipment, materials, and appropriate credits for salvage and accrued depreciation. No summary or lump sum billings, except as may be provided for in the Agreement, will be acceptable as a final statement of cost. Furthermore, reimbursement cannot be made for any items not contained in the original agreement unless amended by an approved allotment request and agreement modification.

**4.5.D. Certification of Final Costs** - Final bills, for other than lump sum agreements, shall contain a certification, by an appropriate officer of the Utility (i.e. Controller, Chief Financial Officer, Accounting Department Manager, City or County Manager, etc.), that all items billed reflect actual expenditures by the Company for the relocation or adjustment of its facilities. An acceptable form of certification follows:

"This is to certify that the costs for labor, equipment, materials, supplies, contractor payments and other items included in this final bill reflect actual expenses incurred by the Company for the relocation and adjustment of its facilities under the contract agreement for which the bill is submitted and that records to support all charges are on file in the Company's offices at *(insert company address)*."

**4.5.E. Audit by Department** - Invoices, time sheets, and other source documents supporting the utility's work performed under an Agreement or contract with the Utility will be subject to an audit by the Department to determine or validate the actual eligible cost of the relocation as provided for herein.

**4.5.F. Documentation of Costs -**

**4.5.F.1. Detailed Records Required** - The Utility shall maintain an accounting system adequate to support and document all expenses claimed for reimbursement under the Agreement. As a minimum, the requirements of 23 CFR Part 645 shall be met. As a supplement to the CFR, "Reimbursement Guidelines and Billing Procedures for Utility Adjustments" is available as a reference. (See GDOT's Utilities webpages.)

**4.5.F.2. Retention of Records** - All records and accounts shall be subject to audit by the Department and by the FHWA for a period of 3 years from the date final payment has been received by the Utility.

## **4.6 LOCAL GOVERNMENT PROJECTS**

**4.6.A. Lighting Projects** - Local Governments may desire to provide lighting at select locations along an interchange, intersection, or roadway corridor within their jurisdiction. This lighting may be conventional roadway lighting or high mast tower lighting, as the location dictates. If the project meets established criteria, then the Department may participate in the costs associated with such

work. This type of project may be completed outside of a GDOT Let project through either a Force Account Utility Agreement or through a Bid Process Utility Agreement. In either case, “Procedures for Assistance to Local Governments When Not Included in Parent GDOT Let Project” (see GDOT’s Utilities webpages) outlines the requirements for completing this work.

#### **4.7 JOINT USE OF UTILITY FACILITIES –**

The purpose of this policy is to ensure timely project delivery by encouraging coordination as it relates to multiple facilities occupying or attaching to a utility pole(s); and to encourage the use of joint-use facilities to minimize obstructions in the right of way for Minor Projects as defined by the GDOT PDP. All other projects shall follow the prescribed procedures in the PDP.

**4.7.A. Attachment to Joint-Use Poles** - All parties that wish to make an attachment to these poles shall coordinate all attachments with the pole owner. All GDOT attachments require the completion of a Pole Attachment Permit with the pole owner. Contact the District Utilities Engineer for the current copy of this form.

**4.7.B. Preconstruction Procedures** - Coordination for the utilization of joint-use poles should begin during concept development and early in the Preliminary Design Phase. The District Utilities Engineer should provide guidance to the Team at a Kick Off/Concept Team Meeting, Utility Field Meeting and during the Preliminary and Final Design Phases. The Team may include but not be limited to Utility owners, Designers, GDOT Project Manager, District Utility Office, District Traffic Operations Office and District Construction Office. GDOT Let projects shall include the “Insurance Protection of Utility Interests” Special Provision requiring Contractors to obtain and keep in-force insurance throughout the life of the project.

All poles that require Make-Ready Work shall meet all current specifications and standards. Existing attachments in violation of the NEC, NESC, Pole Owners, GDOT TS-08 Detail, or Make-Right Work, as installed by the utility owners or others, shall be corrected at no cost to the Department.

##### **4.7. B.1. Overhead/Subsurface Utility Engineering (SUE) Projects –**

**Existing Poles** - It is desirable to use Overhead/Subsurface Utility Engineering (SUE) to determine existing utility owners/locations; POA and traffic signal interconnect information on projects with 5

or more intersections. The request for SUE should be made by the District Utilities Engineer, Project Manager, or State Subsurface Utility Engineer during the Project Team Initiation Process (PTIP) Meeting.

The following tasks will be performed to ensure proper utility coordination is performed during the project's development.

- GDOT Project Manager will initiate a Kickoff meeting after the development of the Concept Report to assess the initial utility impacts and components needed for the design of the project.
- After the completion of SUE services, the GDOT Project Manager will coordinate and conduct a Utility Field Meeting. At this meeting, the Team should walk the project and visually inspect utilization of existing poles and Points of Attachments (POA's), pole type/class, utility owners, guying requirements, if the use of a self-supporting pole or a timber pole is more practical, etc. The determination of joint-use should consider constructability, project construction time, utility construction time, right-of-way considerations, and the cost of Make-Ready Work.
- Corrected project plans and Utility Field meeting minutes will be provided to the utility owners prior to the Preliminary Field Plan Review (PFPR). From this information, utility owners can identify any discrepancies and begin to develop the relocation design(s) and/or Make-Ready worksheets, if applicable. Traffic signals that are added after the Utility Field meeting shall be discussed by the Team to ensure proper coordination and reduce project delays.
- After the completion of the PFPR and prior to the Final Field Plan Review (FFPR), corrected plans with elements of the signal design, including an estimated range of proposed POA's and loading, should be provided to the utility owners to finalize the relocation design(s) and/or Make-Ready worksheets, if applicable.
- The FFPR plans will incorporate the relocation design(s) and/or Make-Ready worksheets, if applicable, from the utility companies. If any changes that affect joint-use poles are identified at FFPR, a review and discussion by the Team will be required prior to changes being accepted.



**4.7.B.2. Non-SUE Projects/New Installations** – For projects that do not utilize the services of SUE and/or have less than 5 traffic signals, the responsible party for preliminary engineering will perform survey to include but not limited to the Edge of Pavement (EP) and curb/gutter, and property and R/W data. Once survey is complete, the District Utilities office will submit a set of plans to the utility owners to identify the location of existing underground facilities. Existing POA's will be determined during the Utility Field Meeting.

After the completion and submission of marked plans, the GDOT Project Manager will coordinate and conduct a Utility Field Meeting. At this point, follow the remaining procedures in accordance with section 4.7.B.1

**4.7.C. Construction Requirements** – When joint-use poles are utilized, the Project Engineer, Contractor and the Utility Owners shall review the project for placement of mast arms, strain poles and joint-use poles for placement verification. The Department's Standard Specifications, Section 647.3.03 Preparation, shall be followed. If there is a redesign in the plans or changes made by the Contractor, the Utility Owners will have 30 days for re-engineering purposes. The Utility Owner shall submit a revised Work Plan (Utility Adjustment Schedule) in accordance with Section 4.4.B of this Manual. Make-Ready worksheets may be used in conjunction with the UAS if warranted by the scope of the project.

All field decisions shall be documented and distributed to the Team by the WUCS for verification. The District Utilities Engineer and the Project Manager will have final determination on plan modifications for all Department Projects.

The Utility Owner or Designee shall have the right to visit and inspect the work at any time and advise the Department's Engineer of any observed discrepancies or potential problems. The cost of any Utility Owner or Designee visits or inspections will be the responsibility of the Utility Owner, unless the costs are covered by a Standard Utility Agreement or related document. The Department agrees to notify the Utility Owner when all utility traffic signal work is complete and ready for final inspection and to invite the Utility Owner to attend the final inspection or provide a corrections list to the Department prior to the final inspection.

**4.7.C.1. Work by Local Government** - If the actual work on joint-use facilities is to be done by a Local Governmental agency under contract with the Department, the Local Government will be

required to make any arrangements for the joint-use of utility poles, except that reimbursement to the utility for any eligible expenses would be paid by the Department.

**4.7.D. Maintenance** - The governmental agency that will be responsible for maintaining the joint-use facility will be responsible for arranging for access and coordination of maintenance work with the Utility.

**4.7.E. Reimbursement Criteria** - A Standard Utility Agreement will be processed exclusively with the pole owner in the event that there are no existing GDOT communications or traffic signal points of attachment and the new POA requires Make-Ready Work or adjustment of existing facilities.

There will be no reimbursement if the Department is over lashing on existing POAs.

When the Department installs its own facilities, such as mast arms, strain poles, or other transportation facilities, relocations or adjustments to clear horizontal and/or vertical conflicts is not considered as Make-Ready Work. This work is not eligible for reimbursement unless the pole owner can provide prior rights information under 4.2.A.2 Case 1. If determination of reimbursement is unclear, the final determination of reimbursement criteria will be made by the State Utilities Engineer.

## **4.8 INSTALLATIONS TO SERVE A HIGHWAY PURPOSE**

The Department may participate in the cost to install facilities such as lighting, water, sewer, power, gas, and telecommunications service to serve a highway purpose where the ownership of such facilities is to remain with a Utility when it is found to be in the public interest. Participation shall be limited to the actual cost of new facilities installed or betterments required less appropriate credit for anticipated new revenue to be derived from the service installation as determined by the Utility. The credit to be given shall be in accordance with the Utility's policy for extending like service to its other customers. The Agreement under which such costs are reimbursed shall be prepared in the same manner as other agreements, as described in this Chapter. Such Agreement shall provide assurances that the Utility will:

- A. Adequately maintain such facilities and maintain continuous quality services, in accordance with this Manual and other State requirements,  
AND
- B. Record the cost of such facilities as a contribution by the State and maintain related

accounting records in accordance with applicable provisions of the Uniform System of Accounts prescribed by the Federal Energy Regulatory Commission (FERC), its equivalent or successor for electric and gas facilities,

AND

- C. Eliminate from the rate determination process (1) the original cost to the State of all such facilities and, (2) the corresponding current and cumulative depreciation amounts,

AND

- D. Relinquish ownership and possession of all such facilities and any property interests to the Department should the utility either go out of business or be sold to another company unwilling to abide by the terms of the agreement.

**This Page Intentionally Left Blank**

## **CHAPTER 5: UTILITY ACCOMMODATION** **CONTROLS AND STANDARDS**

### **5.1 GENERAL CONSIDERATIONS**

#### **5.1.A. Location of Facilities Within the Right-of-Way -**

**5.1.A.1. Longitudinal Installations** - Longitudinal installations are to be located on uniform alignment, as near as practical, to the right-of-way line in order to provide a safe environment for traffic operation, minimize interference with highway drainage, the structural integrity of the traveled way, shoulders, and embankment, and preserve space for future highway improvements or other utility installations. Longitudinal installations are not to be located within the pavement or between the edge of pavement and the ditch or toe of front slope. Exceptions may be granted where no other practical alternative exists. Please see Table 3.1, in Section 3.2.C of this Manual, for permit approval requirements.

#### **5.1.A.2. Crossings**

**5.1.A.2.a. Aerial Facilities Right-of-Way Crossings** - normal to the travel way except where impractical due to topography, existing easements or other features. Repetitive crossings associated with generally parallel construction shall not be allowed, primarily, for the purpose of minimizing easement strips or tree clearing requirements. Exceptions with justification may be approved by the State Utilities Engineer.

**5.1.A.2.b. Aerial Facilities Roadway Crossings** - should be designed to minimize the number of fixed objects, number of crossings, and/or total crossing length.

**5.1.A.2.c. Underground Facilities Right-of-Way Crossings** - normal to the travel way except where impractical due to topography, existing easements or other features.

**5.1.A.2.d. Underground Facilities Roadway Crossings** - normal to the travel way to the extent feasible and practical.

**5.1.A.3. Use of Drainage Culverts** - Installation of underground utility facilities in highway drainage culverts shall be prohibited.

**5.1.A.4. Clearances** - The horizontal and vertical clearances of utility facilities within the right-of-way shall conform to the current National Electric Safety Code (NESC) and the current AASHTO *Roadside Design Guide* applicable for the system, except where greater clearances are required in this Manual, depending on the type of highway and specific conditions for the particular highway section involved. Above ground utility facilities are a form of roadside obstacles, and their location must be consistent with the clearances applicable to all roadside obstacles for the type highway involved.

**5.1.A.5. Preservation of Safety, Visual Quality, and Maintenance Efficiency** - Consideration shall be given to the measures, reflecting sound engineering principles and economic factors, necessary to preserve and protect the integrity and visual quality of the highway, its maintenance efficiency, and the safety of highway traffic.

**5.1.B. Utility Facilities Installed Inside and Parallel to the Right-of-Way** - The policy of the Department is to permit and encourage utilities to locate their facilities within the right-of-way in cases where they can be safely accommodated. The typical location for the installation of utility facilities is in the back 5 feet of the right-of-way. However, if the right-of-way width is sufficient to meet the clear zone/safety requirements and still have additional right-of-way area, the Department may allow the utility facility to encroach further into the right-of-way (see Example 1 at the end of Section 5.1.C.4 of this Manual); thus eliminating the need for private easements off of the right-of-way.

**5.1.C. Utility Facilities Installed Outside and Parallel to the Right-of-Way** - The policy of the Department is to permit and encourage utilities to locate their facilities within the right-of-way in cases where they can be safely accommodated. In some cases however, such as narrow right-of-way, on urban streets with closely abutting features, and other prevailing conditions, utility facilities may not be safely accommodated, and, thus, the utility may have to install their facilities outside of the right-of-way. In other cases, the utility may choose to install their facilities outside of the right-of-way without regards to determining whether or not the right-of-way is available for their use.

In either case, if the utility locates their facilities outside of right-of-way, but still needs access from the right-of-way to construct (which may include clearing and trimming of trees on Department right-of-way), maintain, and operate the said facilities, they shall obtain permission thru GUPS from the Department and the following rules shall apply:

1. The Department will review its Construction Work Program and determine if the proposed installation is in conflict with an active project. A permit shall be issued if it is determined that there is no conflict. See the Vegetation Management Policy in Chapter 6 of this Manual for information regarding clearing and trimming of trees for new installations. The Utility shall clearly show on the plans the width to be cleared on the right-of-way.
2. If it is determined that there is a conflict with an active project, then the utility should agree to install their facilities beyond the limits of any proposed (additional) right-of-way which is required for the active project. It would be in the best interest of both parties, as well as the general public, for the utility to locate their facilities in such a manner that will eliminate the need for additional costs due to the planned project. Typically, no permit will be issued unless the utility demonstrates that they can install their facilities in such a manner that will avoid conflicts with the active project.
3. If the Utility chooses to install their facilities outside of the right-of-way without regards to the availability of right-of-way, the entire physical structure (poles, wire, insulators, etc.) shall be located off of the right-of-way (see Example 2 at the end of Section 5.1.C.4 of this Manual). Any facility located outside of the right-of-way may clear and trim inside the right-of-way by obtaining permission from the Department thru GUPS. The Utility shall clearly show on the permit plans the width to be cleared on the right-of-way. Refer to Chapter 6 of this Manual for complete details for information regarding clearing and trimming of trees for new installations. If the Department needs to place a structure for transportation purposes (i.e. signal pole, overhead strain pole, bridge, wall, etc.) which may encroach upon the said utility facilities' clearance requirements, the Utility shall relocate at no cost to the Department.
4. If it is determined there is no conflict with an active project and the Department has insufficient right-of-way to safely accommodate the utility facility, the Department will allow the overhanging of the right-of-way by the utility facility (see Example 3 at the end of Section 5.1.C.4 of this Manual). The Utility shall obtain permission from the Department thru GUPS. The Utility shall clearly show on the permit plans the width to be cleared on the right-of-way. Refer to Chapter 6 of this Manual for complete details for information regarding clearing and trimming of trees for new installations. If the facilities are in conflict with an active project,

and it requires the relocation of the facilities, a percentage agreement for reimbursement to the Utility may be coordinated during the preliminary engineering phase of the active project by the District Utilities Engineer.



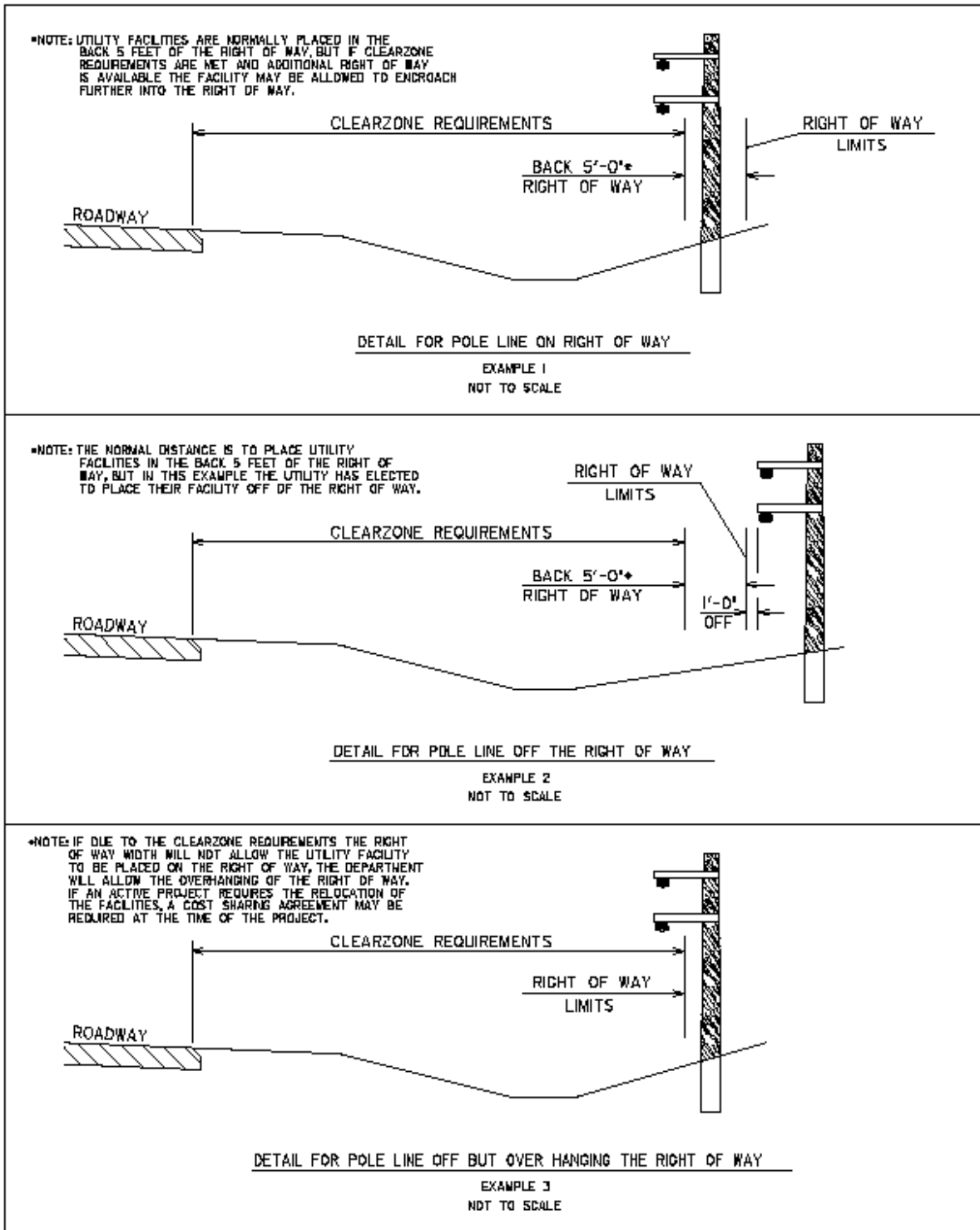

### 5.1.D. Design of Utility Facilities -

**5.1.D.1. Responsibility for Design** - The utility company shall be responsible for the design of the utility facility to be installed within the right-of-way or attached to a highway structure. The Department shall be responsible for review and approval of the utility's proposal, particularly the manner in which the utility facility is to be installed and its location.

**5.1.D.2. Governing Codes** - Except where a higher degree of protection is required by the permit Special Provisions, by industry or governmental codes, or by laws or codes of the public authority having jurisdiction over the utility, all utility installations in, on, along, over, or under the right-of-way and utility attachments to highway structures shall, as a minimum, meet the following requirements:

- a. Electric power and communication facilities shall conform to the National Electrical Safety Code (NESC), current edition.
- b. Water lines shall conform to current specifications of the American Water Works Association (AWWA) and the Department's Standard Specifications, current edition.
- c. Pressure pipelines shall conform to the current applicable sections of ASME Standards of Pressure Piping of the American Society of Mechanical Engineers (ASME), 49 CFR, Part 190, et. seq., and applicable industry codes.
- d. Liquid petroleum pipelines shall conform to the current applicable sections of API RP 1102 Steel Pipelines Crossing Railroads and Highways of the American Petroleum Institute (API) for pipeline crossings under highways.
- e. Any pipeline carrying hazardous materials shall conform to the rules and regulations of the U.S. Department of Transportation (USDOT) governing the transportation of such material.
- f. No pipeline company shall exercise the right of eminent domain for the construction of a pipeline without first obtaining from the Commissioner a certificate that such action is authorized pursuant to the provisions of Title 22-3-83 of the O.C.G.A. See Chapter 672-13 of the Department's Board Rules.
- g. Utilities will be responsible for meeting the applicable OSHA regulations and all safety requirements. All work within the right-of-way must be done in a safe and lawful manner. Any excavation or trenched construction must be appropriately shored and workers must be adequately protected.

### **5.1.D.3. Design Criteria for Pipelines -**

- a. Pipelines located in casings or utility tunnels are to be designed to withstand expected internal pressure and to resist internal and external corrosion; and, in addition, uncased buried pipelines are to be designed to withstand external pressure.
- b. The Department will review plans and specifications to reasonably determine that the roadway will not be damaged. The utility will be responsible for design to satisfy code requirements and soil pressures, including those imposed by boring or jacking.
- c. All utility facilities shall be installed in a manner that will make them locatable using a generally accepted electronic locating method. Non-metallic facilities shall be installed with electrically continuous tracer material to enable pipe and cable locates.

**5.1.D.4. Appearance Requirements** - Utility facilities located above ground are to be of a design compatible with the scenic quality of the specific highway being traversed.

**5.1.D.5. Materials Requirements** - All utility installations in, on, along, over, or under the right-of-way and attachments to highway structures are to be of durable materials designed for long life expectancy and relatively free from routine servicing and maintenance. Use of asbestos cement pipe will not be permitted.

**5.1.D.6. Provisions for Expansion** - On new installations or adjustments of existing utility facilities, particularly those located underground or attached to bridges, provisions shall be made for known or planned expansion. They are to be planned so as to avoid interference with highway traffic when additional overhead or underground lines are installed at a future date.

### **5.1.E. Preservation, Restoration, and Cleanup -**

**5.1.E.1. Disturbed Areas** - The size of the disturbed area shall be kept to a minimum. Construction methods are to be in accordance with the Department's Specifications and Special Provisions as referenced in Section 3.4.C of this Manual.

**5.1.E.2. Drainage** - Care must be taken in utility installations to avoid disturbing existing drainage facilities.

### **5.1.F. Safety and Convenience of Traffic -**

**5.1.F.1. Traffic Control** - Traffic control for utility construction and maintenance operations shall conform to Sections 2.9, 3.7, and 4.4.A.5 of this Manual.

**5.1.F.2. Closing of Trenches or Pits** - Whenever open trenching is required for the installation or maintenance of facilities within the right-of-way, the work shall be scheduled so that not more than 500 feet of trench shall be open at any one time. More restrictive controls may be imposed where conditions warrant. Insofar as possible, work shall be scheduled so that open excavations will not be left overnight. Where trenches or pits are within the clear zone and cannot be backfilled before leaving the job site, they shall be covered by metal plates of sufficient thickness and size to safely support traffic.

**5.1.F.3. Storage of Materials** - The storage of materials on the right-of-way within the clear zone is prohibited. Storage of materials outside the clear zone shall be temporary only, for a sufficient duration to facilitate their incorporation into the construction which shall be expeditiously pursued.

**5.1.F.4. Residential and Commercial Driveways** - It shall be the responsibility of the Utility to notify property owners at least 72 hours in advance of when driveways are to be cut or blocked and to provide temporary measures to maintain access during the work. No resident or business shall be denied vehicular access to their property for any length of time other than, as determined by the Department, is absolutely necessary. Where two or more existing driveways are present for a business, only one existing driveway shall be closed at any time. The Utility shall maintain sufficient personnel and equipment on the work site at all times to ensure that ingress and egress are provided when and where needed. Stone or cold mix may be used temporarily. Plating may also be required on commercial driveways. The Utility shall restore such driveway to a condition similar or equal to that existing before such driveway cut was done, by repairing, rebuilding or otherwise restoring as may be directed.

**5.1.G. Scenic Enhancement: Areas for Special Protection** - The type and size of utility facilities and the manner and extent to which they are permitted within areas of scenic enhancement and natural beauty can materially alter the scenic quality, appearance, and view of highway roadsides and adjacent areas.

Such areas include scenic strips and byways, overlooks, rest areas, recreation areas, and the right-of-way of sections of highways which pass through public parks, recreation areas, wildlife and waterfowl refuges, and historic sites. Utility installations within all such strips, overlooks and areas of right-of-way shall be avoided except as follows:

**5.1.G.1. Underground Installations** - New underground utility installations may be permitted within such strips and byways, overlooks and areas of right-of-way where they do not require extensive removal or alteration of trees visible to the highway user or do not impair the appearance of the area.

**5.1.G.2. Overhead (Aerial) Installations** -

a. **New Overhead Installations** - New overhead (aerial) installations are to be discouraged at such locations. However, overhead installations of electric power lines may be permitted upon the following conditions:

1. Where other utility locations are not available, or are extremely difficult and unreasonably costly, or are less desirable from the standpoint of scenic appearance
2. Where the placing of the utility underground is not technically or economically feasible or is more detrimental to the scenic appearance of the area
3. Where the proposed installation can be made at a location and in a way that will not significantly detract from the scenic quality of the area being traversed and can be suitably designed, and materials used, to give adequate attention to aesthetic values.

b. **Existing Overhead Installation** - In scenic areas, existing overhead installations shall be allowed to be maintained and/or upgraded. If there is a request to convert from aerial to underground, please refer to Section 2.10 of this Manual.

## **5.2 UNDERGROUND UTILITY FACILITIES**

### **5.2.A. Location and Alignment** -

**5.2.A.1. Considerations** - There are several reasons for advocating crossings generally normal to the highway alignment. Oblique highway

crossings have several objections: they increase interference with highway traffic during construction; they are more likely to conflict with other highway facilities; they upset distribution of live loads to the subgrade and across joints in the pavement, and they leave more conspicuous patches in the pavement to be repaired if the backfill subsides.

From the Utility viewpoint, normal crossings may introduce bends outside the highway which reduce efficiency in transmission of the utility. However, oblique alignment of new crossing adds considerably to the cost, acting as an economic control.

**5.2.A.2. Controls for Locating Underground Utility Facilities** - The following controls are applicable to the location and alignment:

1. The angle of crossing shall be normal, or nearly so, for facilities 6 inches or less in diameter and for trenched installations cutting any part of the roadway. For all other crossings, the angle of crossing should be based on economic considerations of practical alternates.
2. Conditions which are generally unsuitable or undesirable for crossings are to be avoided. These include locations in deep cuts; across cuts and fills on steep slopes; near footings of bridges and retaining walls; across intersections at grade or ramp terminals; at cross drains where flow of water, drift or streambed load, may be obstructed; within basins of an underpass drained by a pump if pipeline carries a liquid or liquefied gas; and in wet or rocky terrain where it will be difficult to provide minimum cover.
3. All new or relocated longitudinal installations shall be located on uniform alignment, parallel to the roadway and as near as practical to the right-of-way but not less than 3 feet beyond the slope, ditch, or curb lines.
4. All locations shall be reviewed by the Department to ensure that the proposed utility installation will not severely interfere with existing or planned highway facilities or with highway maintenance and operation.

**5.2.B. Cover (Depth) -**

- 5.2.B.1. Considerations** - The critical control for cover on a crossing is the low point in the highway cross section. Usually, this is the bottom of the longitudinal ditch. In establishing the depth below an

unpaved ditch, allowances must be made for potential increases in ditch depth resulting from erosion, ditch maintenance operations, or the need to increase the capacity of the ditch. On longitudinal installations, the critical controls are usually the depths of lateral drainage facilities, landscaping, buried cable, bridge structures, and highway maintenance operations.

#### **5.2.B.2. Controls for Cover -**

a. The cover shall be established as follows:

##### **Utility Facilities Crossing**

- Under pavement surface of Interstate and Limited Access highways: 10 feet, including all ramps
- Under pavement surface of all other highways: 4 feet
- Under other surfaces, including unlined ditch: 3 feet
- Under sidewalk, paved ditch or ditch gutter: 2 feet
- (See Figure 2, at the end of Section 5.2.B.2.c of this Manual)

##### **Utility Facilities Longitudinal**

- No facilities under pavement surface of Interstate and Limited Access highways
  - Under pavement surface and sidewalks of all other highways: 4 feet
  - Under unpaved surfaces: 3 feet
  - Under paved ditch: 2 feet
  - For trunk line communication and cable facilities direct buried in the back five feet of the right-of-way: 2 feet to top of cable, all others 3 feet.
  - For communication and cable service line facilities only: minimum buried depths shall be based on the method of installation set by the Utility Facility Owner; except when the facility is to be installed under pavement, the installation depths shall be as listed above.
- b. On non Interstate and non Limited Access highways, for flexible pipe installations under pavement, the minimum cover shall be 4 feet or the outside diameter of pipe, whichever is greater.
- c. Where less-than-minimum cover is essential to avoid conflicts, the top of pipe or other facility must not project into the pavement subbase, and shall be protected with a casing, capping or other method acceptable to the Department.

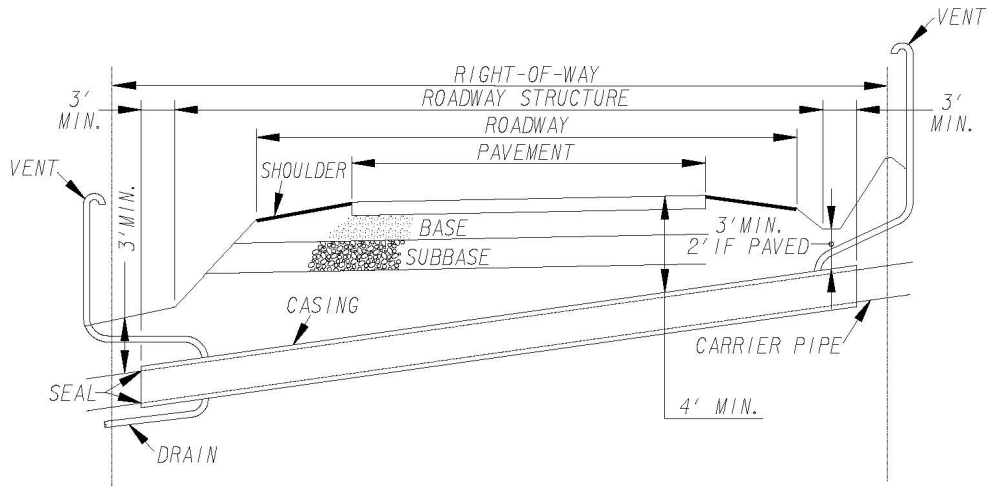

(a) ENCASED CROSSING

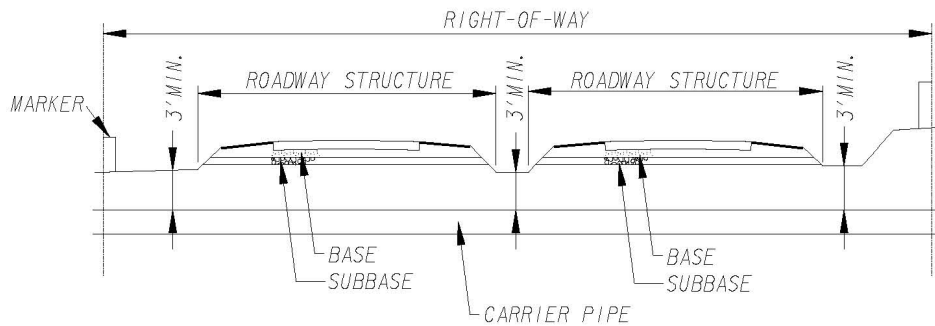

(b) UNCASED CROSSING

DEPTH OF BURY

FIGURE 2



### 5.2.C. Encasement -

**5.2.C.1. Considerations** - Encasement may include complete or partial enclosures designed to protect the carrier, lighten its burden, facilitate its insertion and withdrawal, or guarantee integrity of the earth structure. (See Figure 3, at the end of Section 5.2.C.2.f of this Manual).

**5.2.C.2. Controls for Encasement** - The following controls are applicable for providing encasement of utility crossings of the highway:

- a. When an encasement is used and designed as a pressure vessel, the encasement pipe will have strength equal to or exceeding the carrier pipe. Where the casing is not a pressure vessel, the casing pipe shall be capable of supporting a minimum external load of 2200 PSF at 48 inches, minimum depth, and per other requirements found in this Manual or those of a Railroad operating a rail corridor if more stringent.
- b. All facilities with a wash factor crossing under Interstates and other controlled access highways or carrying hazardous (flammable, corrosive, expansive, energized, and/or unstable) materials under pressure shall be cased. The casing shall extend from right-of-way to right-of-way.
- c. All facilities greater than 4 inches in outside diameter and crossing under non-controlled access highways carrying hazardous (flammable, corrosive, expansive, energized, and/or unstable) materials under pressure or having a wash factor shall be cased. Casing shall extend a minimum of 10 feet beyond the edge of pavement or beyond toe of slope or ditch line, whichever is greater. In an area with curb, the casing must extend a minimum of 3 feet beyond the back of the curb. The extension of encasements may be required by the Department in some cases to allow for future widening of the highway and for protection of the right-of-way.
- d. Encasement may be required for any facility located with less than minimum clearances or near bridge footings or other highway structures or other elements, such as high voltage power lines, flood channels, and subsiding ground.
- e. Casing shall be sealed at the ends to prevent debris and moisture from entering the annular space between the casing and carrier pipe.
- f. Sag pipes (inverted siphons) should be avoided whenever there is the possibility of sedimentation collecting in the sag. Where use

of sag pipe is unavoidable, provisions for draining the sag shall be required.

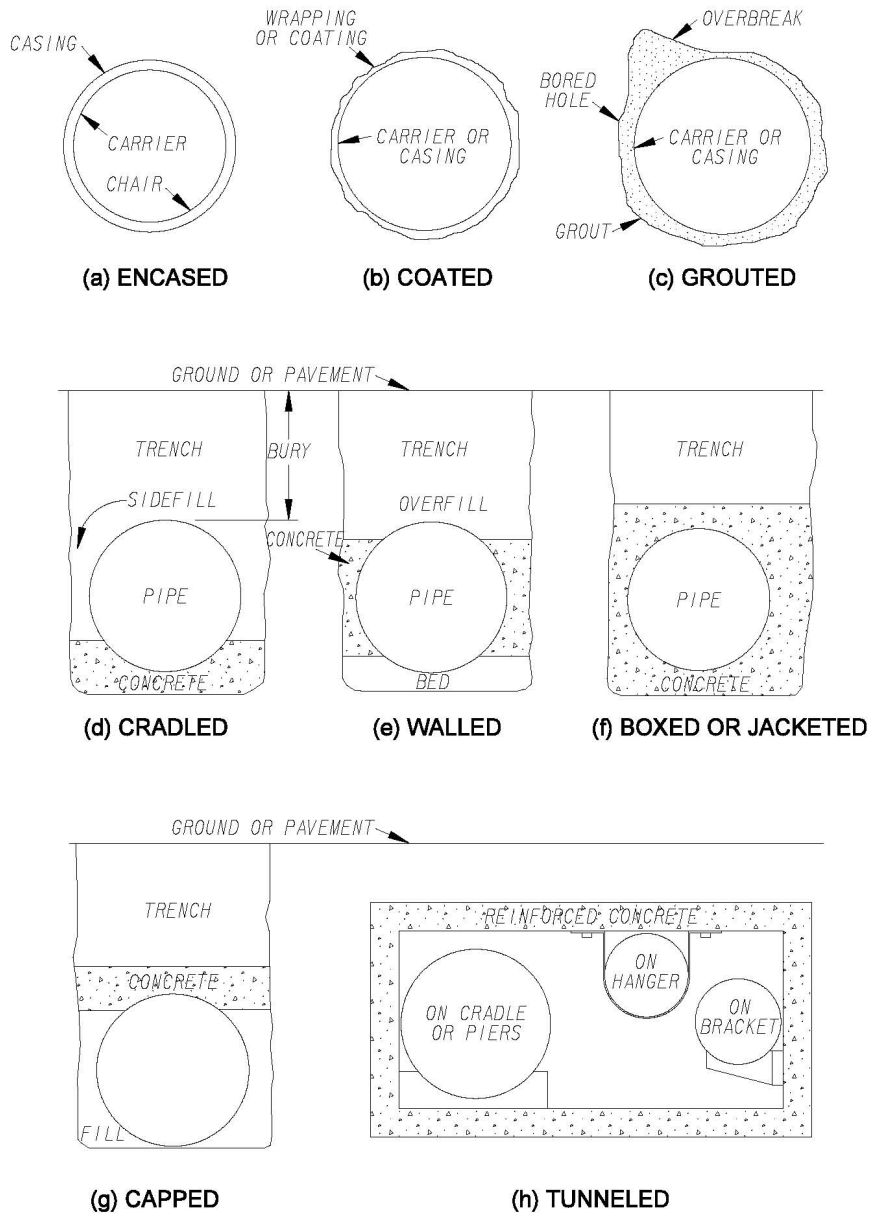

TYPES OF ENCASEMENT

FIGURE 3

**5.2.C.3. Controls for Uncased Carriers** - For conditions not outlined in Section 5.2.C.2 of this Manual, crossings of the highway may be installed without encasement. An uncased carrier crossing a highway becomes an integral part of the earth structure supporting the pavement. Just as for a culvert, the Department must be assured of the adequacy of the structural design. This design must consider the complication of internal pressure and the nature of the transmittant. Controls for uncased carriers are to be designed to withstand all of the following load combinations:

- a. Earth and live load
- b. Internal pressure
- c. Earth and live load plus internal pressure  
AND
- d. Earth and live load plus alternations of full and zero internal pressure. For near grade summits of liquid carriers, the "zero internal pressure" used in design shall be taken as absolute, that is, under vacuum.

Such installations shall include a higher factor of safety in the design, construction and testing than would normally be required for cased construction.

Uncased crossings of pipelines transmitting natural gas may be permitted, provided such pipelines conform to 49 CFR, Part 192 or Part 195, as applicable.

**5.2.D. Controls for Hazardous Transmittants** - Hazardous transmittants are those which are flammable, corrosive, expansive, energized, and/or unstable. Controls for hazardous transmittants follow:

**5.2.D.1. Cathodic Protection** - Cathodic protection shall be provided on all new installations of metallic pipelines carrying hazardous transmittants. Controls for cathodic protection are as follows:

1. Any cathodic protection anode bed or deep anode well shall not be placed within 20 feet of any structure or culvert.
2. Shallow anode bed types exceeding 48 inches in width shall not be permitted in the right of way. All others must have a depth of coverage of at least 36 inches. Deep well anode beds of up to

60 inches in diameter are acceptable. Rectifier and meter loop poles shall be placed at or near the right of way line.

3. Any cathodic protection anode beds, deep anode wells, rectifiers, and/or meter loop poles located in the right of way line shall be marked as per Sections 5.2.D.3 and 5.2.E.3 as applicable.
4. See Section 5.7.B for additional information concerning cathodic protection around bridge structures.

**5.2.D.2. Encasement** - For encasement requirements, see Section 5.2.C of this Manual.

**5.2.D.3. Markers** - Markers shall be required for pipelines carrying hazardous transmittants in accordance with 49 CFR, Part 190, et. seq.

### **5.2.E. Controls for Appurtenances -**

**5.2.E.1. Vents** - Vents are appurtenances by which fluids between carrier and casing may be inspected, sampled, exhausted, or evacuated. These fluids may be leakage from the carrier within the casing or the soil without, or atmospheric vapor and condensate, or decomposition products of pipes and coatings. Liquid or heavy gases can be vented by gravity drains; light gases are exhausted through risers or standpipes projecting above the ground surface. Vent standpipes shall be located and constructed so as not to interfere with maintenance of the highway nor be concealed by vegetation; preferably they should stand on a fence or right-of-way line.

**5.2.E.2. Drains** - Where drains are necessary for casings, vaults or other facilities, they shall be shown on the permit drawings. Drains may outfall into roadside ditches or natural water courses at locations approved by the Department. Such outfalls shall not be used as a waste way for purging the carrier unless specifically authorized by permit.

**5.2.E.3. Markers** - If markers are used, the location and emergency information shall be marked conspicuously for all underground facilities. Markers may be signs on vents or on special posts at the fence or the right-of-way line. They should be provided at one end of a normal crossing, at both ends of an oblique crossing, and at

reasonable intervals along a longitudinal installation. Markers should not be located in close vicinity to visible and obvious above ground utility facilities of the same type. Information on markers shall include pipeline identification, owner of pipeline and location of local office and emergency telephone number, including area code to contact.

**5.2.E.4. Manholes, Vaults, and Hand Holes** - Manholes, vaults, and hand holes are to be designed and located in such a manner that will cause the least interference to traffic, other utilities, and future highway expansion. These structures shall be limited to those necessary for installation and maintenance of underground lines.

On rural highways, these structures shall not be placed within the roadbed structure. Also, it is desirable for them to be placed outside the ditch limits and as near as practical to the right-of-way line. However, in cases where they must be installed in the ditch, they shall be flush and have a water tight cover. In addition, the ditch shall be paved with concrete (in accordance with Department standards) a minimum of 10 feet on both sides of the structure.

On urban highways, these structures shall not be placed within the roadway, which includes the curb and gutter. It is desirable for them to be placed outside the sidewalk limits and as near as practical to the right-of-way line. However, in cases where they must be installed in the sidewalk due to limited right-of-way, the installation shall meet ADA requirements.

Exceptions to the above requirements shall be reviewed and approved by the State Utilities Engineer.

These exceptions shall be made only at those locations where manholes, vaults, and hand holes are essential parts of existing lines that have been permitted to remain under existing or proposed roadways. (See Sections 2.8.B and 5.3 of this Manual for additional information on retention.) When adjustment to grade is approved for manholes, vaults, and hand holes that will be retained in the pavement, the adjustment shall be treated as an open cut and repaired in accordance with Section 5.2.F.2 of this Manual or repaired using an “Approved Manhole Method”. (See Section 5.4 of this Manual.) Manholes shall be flush with finish grade within roadbed limits and shall protrude no more than 4 inches above grade in other areas of relatively flat grade.

- 5.2.E.5. Fire Hydrants** - Hydrants shall be located as near as practical to the right-of-way line. Where necessary, in order to permit access by fire trucks, hydrants may be located inward from the right-of-way subject to the following controls:
- a. In rural-type areas where speed limits are 50 mph or greater, hydrants shall be located as near to the right-of-way as practical. On heavily-traveled arteries, hydrants should be located at side roads, driveways, ramps, etc., insofar as practical, to allow a setback from the pavement and still provide a means of access. Breakaway design shall be specified for all hydrants located within the clear zone.
  - b. In urban areas with curb and guttering where speed limits are 45 mph or greater, hydrants shall be placed 12 feet from the face of curb. Where speed limits are greater than 35 mph but less than 45 mph, hydrants shall be placed 8 feet from the face of curb; and for speeds 35 mph or less, hydrants shall be placed 6 feet from face of curb. All hydrants shall be of breakaway design, and, in all of the above cases, the facility shall not encroach upon current ADA sidewalk clearances.
  - c. Blue reflective raised pavement markers may be used as a method of identifying fire hydrants for firefighting purposes as an option by Local Authorities. A separate permit will be required for this work. The requesting city or county government shall contact the District Traffic Engineer for applicable standards and permit requirements.
- 5.2.E.6. Shut-off Valves** - Shut-off valves or switches shall be installed as near to the right-of-way line as practical, at both sides of all crossings of State Highways and crossings carried on structures. However, valves may be omitted on carrier pipelines within steel casings that extend the full width of the highway.
- 5.2.E.7. Gas Regulator Stations** - These shall consist of either a 1 inch or 2 inch regulator station depending on the piping size of the regulator components in the station. Regulation, relief, and valve components shall be housed below ground in steel or concrete pits or vaults or located off the right-of-way. On both the 1 inch and 2 inch stations, the pits are closed with steel covers flush with the ground. However, some components are, by necessity, above ground, such as the relief or venting stack and instrumentation box, and shall meet any clear zone requirements discussed in Section 5.6 of this Manual. An exception may be granted for the installation of a temporary above ground regulator station on right-of-way in certain cases, such as

cold weather. The permit application shall include a detailed Traffic Control Plan describing how the regulator station will be protected. The temporary installation shall be removed within 30 calendar days from the date of its installation. No permit shall be issued for a temporary above ground regulator station installation without prior review of the District Traffic Engineer.

**5.2.E.8. Power and Communication Facilities** - Wiring cabinets, transformers, pedestals, pad-mounted devices, and similar appurtenances which protrude more than 4 inches above the ground line shall meet the same requirements for location of above ground facilities. (See Section 5.6 of this Manual.)

**5.2.E.9. Pipeline Facilities** - Above ground enclosures and decoy-style lifelike rocks, etc., providing engineered features for freeze protection, security, service access for testing, accessibility for repair and positive drainage to prevent submergence of piping systems, shall not be allowed on right-of-way.

**5.2.F. Installation Methods and Controls** - Installation or replacement of facilities along or crossing existing highways can, for the most part, be controlled by end-product specification. However, safety of traffic and preservation of the earth structure supporting the pavement require some restriction of methods used in the operations. Trenching, boring, plowing, or tunneling for underground installations shall not be closer to any edge of the surfaced portion of the highway than specified in the permit. Acceptable methods of installation are discussed below:

**5.2.F.1 Open Cut Construction** -

**5.2.F.1.a. Controls for Trenched Construction** - The essential features for trench and backfill construction are restoration of the structural integrity of entrenched roadbed, security of the carrier against deformation likely to cause leakage, and assurance against the trench becoming a drainage channel and against drainage being blocked by the backfill. Bedding is important for all pipes. Trenched construction, bedding, and backfill normally will be adequately controlled if the utility conforms to the Department's Standard Specifications, current edition, for earth work and culverts. Specific controls follow:

1. Trenches less than a depth of 5 feet are to be cut to have vertical faces with a maximum width of 2 feet or outside diameter of pipe plus 18 inches and shored where necessary to prevent caving. Trenches at a depth 5 feet and greater shall be shored with some type of protective system, sloped and shielded to prevent loss of trench wall support. The shoring shall extend 18 inches above the surrounding area.

A trench box or shield may be required when excavation is in unstable soil conditions or greater than 5 feet deep. This protective system is either designed or approved by a registered professional engineer or is based on tabulated data prepared or approved by a registered professional engineer.

Designing a protective system can be complex because of the number of factors involved: soil classification, depth of cut, water content of soil, changes due to weather and climate, or other operations in the vicinity. The design method, which can be applied for both sloping and shoring, involves using tabulated data, such as tables and charts, must be approved by a registered professional engineer.

Considerations for sloping and shoring will be based on soil test or as a minimum shall be sloped at 1 ½:1. Excavations over 20 feet in depth shall be designed and approved by a registered design professional.

2. Bedding shall be provided as specified by the utility or pipe manufacturer for the type of conditions encountered. Bedding typically consists of granular soil free of lumps, clods, cobbles, and frozen materials, and is graded to a firm-but-yielding surface without abrupt changes in bearing value. Unstable soils and rock ledges shall be undercut from the bedding zone and replaced by suitable material.
3. Backfilling of trenches must be accomplished immediately after the pipeline or other utility is placed therein or as directed by the Department. Backfill shall be placed in two stages: first, sidefill to the level of the top of pipe; second, overfill to former surface grade. Sidefill shall consist of granular material laid in 6 inch layers, each consolidated by mechanical tamping and controlled addition of



moisture, to a density of 95% as determined by AASHTO T-99 Method D or GDT-67. Overfill shall be layered and consolidated to match the entrenched material in cohesion and compaction. The top 12 inches shall be compacted to 100% of specified density. Consolidation by saturation or ponding will not be permitted. See the Department's Standard Specifications, current edition, for additional information on backfill material.

4. Concrete structures, such as sidewalks and ditch paving, damaged by Utilities during trenching operations or other construction activities shall be removed and replaced in full sections. A section's size will be determined by the sawed joint or expansion joint of the adjacent section or by the Inspector, but in any case no section shall be less than 5 feet in length.

**5.2.F.1.b. Controls for Plowing** - The essential features for plowing construction are:

1. The required location for buried cable or wire will be determined after a thorough consideration of such factors as width of right-of-way, type of road, type of terrain, drainage, and soil conditions. Regarding the latter, sandy-loamy soil offers the best condition for plowing, whereas dry clay soil and soil with more than incidental rock may require underground installations to be placed by machine trenching.
2. Minimum bury for this type installation shall be 24 inches.
3. Plowing is only permitted behind the ditches or beyond the toe of fill slopes. In areas where there is no defined roadbed, plowing will be permitted at a minimum distance of 20 feet from the pavement. It is generally not acceptable to plow under the following conditions:
  - a. In areas of steep slopes, unless an offset plow can be used to avoid excessive damage to the slopes
  - b. In areas that are too wet to support the equipment being used
  - c. In areas of heavy vegetation, unless the path is

- cleared in advance of cable placement
- d. In areas with a heavy presence of rocky soils
  - e. In areas with numerous utilities
4. Acceptable equipment must be on site and in good mechanical condition prior to beginning any plowing operation. All work done in any day must be restored during the same day. Static or vibratory plowing will be allowed provided satisfactory results are being obtained. Some considerations necessary to satisfactory results:
- a. Must maintain the minimum depth as specified
  - b. Must make the rip as narrow as possible for the facility being placed
  - c. Sliding or slipping of equipment will not be allowed
  - d. At least three passes must be made over the rip with equipment heavy enough to restore the rip
  - e. Excessive damage of the right-of-way will not be allowed
  - f. Variations in the proposed locations of the facility will not be permitted
5. The Utility will maintain continuous supervision during all plowing operations, either by an employee of the utility or by some independent contractor other than the contractor performing the plowing. The company will make an in-depth final inspection of the work and make any needed corrections at that time. An inspection will be made in approximately 6 months by the Department. The Utility will be responsible for correcting any settlement or erosion resulting from its construction at any time after the work is completed.

**5.2.F.2 Pavement Cuts** - In State Highways, these can significantly disrupt and interfere with public use of the right-of-way. Among other things excavation can disrupt traffic flow, impede public transportation, and create barriers for pedestrians and bicyclists to navigate. The State Highways are a valuable public asset which the State holds in trust for its citizens, therefore the Department discourages pavement cuts.

**5.2.F.2.a. General Controls** - No open cuts in pavement will be permitted, except by written permission of the District Engineer, for making a service tap on a line under the pavement when no other distribution line is available in the area where the service is required; or, for other reasons where it is shown there is no other practical alternative. In no event will an open cut be permitted when it is reasonably practical to bore, tunnel, etc., under the roadway. The District Utilities Engineer may require test holes in the pavement for the purpose of investigating the location of nearby utilities or performing repairs or taps to existing facilities. (See Section 5.2.F.2.c of this Manual.)

Whenever the District Engineer is requested to authorize an open cut, such request must be made in writing supported by detailed reasons some other method is not practical and giving details relative to the maintenance history and service life of the facility. The Department requires (1) that backfill and repaving be performed under its direction at the expense of the utility, and (2) that the utility remain liable for cost of repair if the backfill subsides or the patched pavement fails. The District Utilities Engineer shall require an inlay or overlay beyond the cut limits for the full width of the lane, lanes or road surface to improve the road smoothness and appearance depending on the age of the last paving operations as follows:

- Existing pavement up to 4 years old – mill and/or overlay 100 feet each side of trench.
- Existing pavement 4 years up to 7 years old – mill and/or overlay 50 feet each side of trench.
- Existing pavement over 7 years old – pavement repair shall be replaced in kind using construction procedures in accordance with the Department’s Standard Specifications, current edition.

If field conditions warrant, as shown above, milling may be required prior to repaving. When approval of the District Engineer is granted, the following provisions shall be adhered to:

1. The trench edges in paved areas shall be saw cut to neat lines before starting to break and remove the pavement slab.
2. Materials and methods of compaction shall be adopted to achieve prompt restoration of traffic service:
  - a. In trenching across the highway, only one-half of the paved surface is to be opened at one time. The open half shall be completely backfilled before opening the other half.
  - b. Closure of intersecting streets, road approaches, or other access points for trenching operations will not be permitted. Upon trenching across such roads or streets, the Utility shall utilize steel running plates of sufficient thickness to support traffic or other satisfactory methods for traffic entering or leaving the road or adjacent properties. Immediately after the utility facility authorized by the permit has been placed, the intersecting street, road approaches, or other access point shall be restored to a condition similar or equal to that existing before such open cut was done and in a manner satisfactory to the Department. Spot resurfacing may be required.
3. Steel plates shall not be used on highways with a posted speed greater than 45 mph. For all other highways the following controls shall apply to the use of steel plates:
  - Shall completely cover the pavement cut or excavation
  - Shall be adequately secured and shall provide a safe and reasonable transition to the adjoining roadway surface
  - Shall be limited to 4 consecutive days unless written approval is granted by the District Engineer
  - Shall be clearly identified with the name or initials of the Utility
  - Temporary traffic control warning signs shall be posted in advance warning motorist about plates in roadway in accordance with the MUTCD.

If the Utility fails to adhere to the above controls, the Department retains the right to remove the plate and perform the necessary work to adequately restore the roadway and the expenses of said work shall be paid and collected as provided in Section 3.3.C of this Manual.

**5.2.F.2.b. Surface Restoration** - This shall be performed with great care and attention to detail to ensure that the structural strength and surface quality of the road is restored.

For trenches over 4 feet wide, the subbase, base, and paving shall be replaced in kind using construction procedures in accordance with the Department's Standard Specifications, current edition.

For trenches up to 4 feet wide, the repaired area should be acceptable, if the following procedures are used:

- 1. Asphaltic Concrete Pavements** - Pavement and trench to be opened to width as shown in Figure 4, Stage 1 (at end of Section 5.2.F.2.c of this Manual). After the utility facility and any necessary bedding has been placed, the backfill and overfill material shall be placed, as described in 5.2.F.1.a.(3), up to the subbase. At this point, the pavement shall be cut back at least 12 inches on each side of the trench, or to visible overbreaks, whichever is greater, to a depth of 2 inches with a concrete saw. This will ensure a straight vertical edge for the patch.

After making the saw cut, the pavement to be removed should be broken into small pieces and removed. The broken edge below the saw cut is left fairly rough and irregular, but is approximately a vertical plane to provide an aggregate interlock between the patch and the existing pavement.

The subbase material shall be carefully placed and shaped. Water shall be added as necessary to provide a damp, but not wet, subbase before the concrete base is placed. The vertical face of the existing pavement shall be sprayed with a fine mist of water to moisten the surface. To further improve the probability of obtaining a bond between the old pavement and the concrete base to be placed, the vertical face of the old

pavement shall be painted with a solution of Portland cement and water mixed to the consistency of heavy paint.

The new Class B concrete base shall then be placed before this surface dries out. The base shall be placed with care, making sure it is worked back into all corners and into the rough surface of the existing pavement. This must be done to provide interlocking between the old pavement and new base being placed.

After the concrete base has cured, the surface of the concrete base and vertical edges of the existing paving must be clean and dry before the tack coat is applied. The tack coat shall be applied to the surface of the new concrete base and brushed into the corners and onto the vertical edges of the old pavement to provide a bond and to seal out water. The hot asphaltic plant mix surface material shall be immediately placed after the surface of the tack coat has dried to the point that it is sticky to the touch.

2. **Portland Cement Concrete Pavement** - Utility cuts in Portland cement concrete pavement are discouraged by the Department. Pavement cuts, but, when allowed, will require complete or partial slab replacement. The District Engineer will determine the extent of slab replacement on a case by case basis if an open cut is allowed. Procedures for slab removal and replacement established by the Department for construction and maintenance projects will be used. All work will be in accordance with the Department's Standard Specifications and Construction Details, current editions. Details for required dowels in replacement concrete and for sawing and sealing joints will be furnished by the Department with approved permits.
3. **Flowable Fill** - Commonly used as a fill or backfill in utility construction, flowable fill is a low strength, slurry-like fill material primarily used in below grade in applications such as utility trenches, where low strength and ease of placement are required, and is typically placed using conventional ready-mix concrete trucks. This mixture is capable of filling all voids in irregular excavations and hard to reach places (such as under and around pipes), is self-

leveling, and hardens in a matter of a few hours, and can be placed in one lift with minimal labor without the need for compaction in layers. In many cases, these materials are designed so that they are comparable in strength to the surrounding soil after hardening, making excavation at a later time possible. It requires no vibration or tamping, and reaches 95% or more compaction within a few hours of placement. It generally is made from a blend of cement, fly ash, sand and water. While flowable fill's initial costs may be higher than most soil or granular backfill materials, by the time labor and other factors are added in, flowable fill may be the best and most economical choice.

Flowable fill is sometimes referred to as controlled density fill (CDF), controlled low strength material (CLSM), lean concrete slurry, and unshrinkable fill. Fine aggregates or fillers (usually sand) are often used in flowable fill mixtures that are produced at ready-mix plants, especially higher strength CLSM mixtures. Portland cement and/or supplementary cementitious materials and water are essential ingredients in all flowable fill mixtures, since it is the hydration of these cementitious materials that enables the flowable fill mixture to harden and develop strength. Acceptable materials and construction with flowable fill within the right-of-way shall conform to the current specifications of the Department's Standard Specifications, current edition, Section 600, Controlled Low Strength Flowable Fill.

**5.2.F.2.c. Test Holes** - The District Utilities Engineer may routinely permit test holes in the pavement for the purpose of investigating the location of nearby utilities to comply with Georgia Utility Facilities Protection Act, O.C.G.A. § 25-9. The District Utilities Engineer may require the utility to consider other locations for pavement crossings to reduce or eliminate the number of test holes necessary. Test holes shall be shown on the permit plans and shall not exceed 12 inches in diameter. In the event multiple test holes are required to locate existing facilities as per O.C.G.A. § 25-9, if three or more test holes per lane are required, the lane shall be open cut and repaired as per Section 5.2.F.2 of this Manual.

The District Utilities Engineer may also require test holes for the purpose of repairing leaking underground facilities or new taps to existing facilities if the pavement in the area is less than 3 years old. The work consists of rotary core boring and the reinstatement process of coring test holes in the roadway and the use of vacuum excavation or comparable nondestructive equipment in a manner as to cause no damage to the existing utility facility. After excavating a test hole, performing the survey or making a repair to the existing facilities, backfill and then reinstating pavement core test hole in asphalt and concrete roads, sidewalks and other paved surfaces. All work shall conform to the Special Provision, Section 205, Roadway Excavation – Test Holes.



UTILITY INSTALLATION BY OPEN CUT  
STAGE CONSTRUCTION

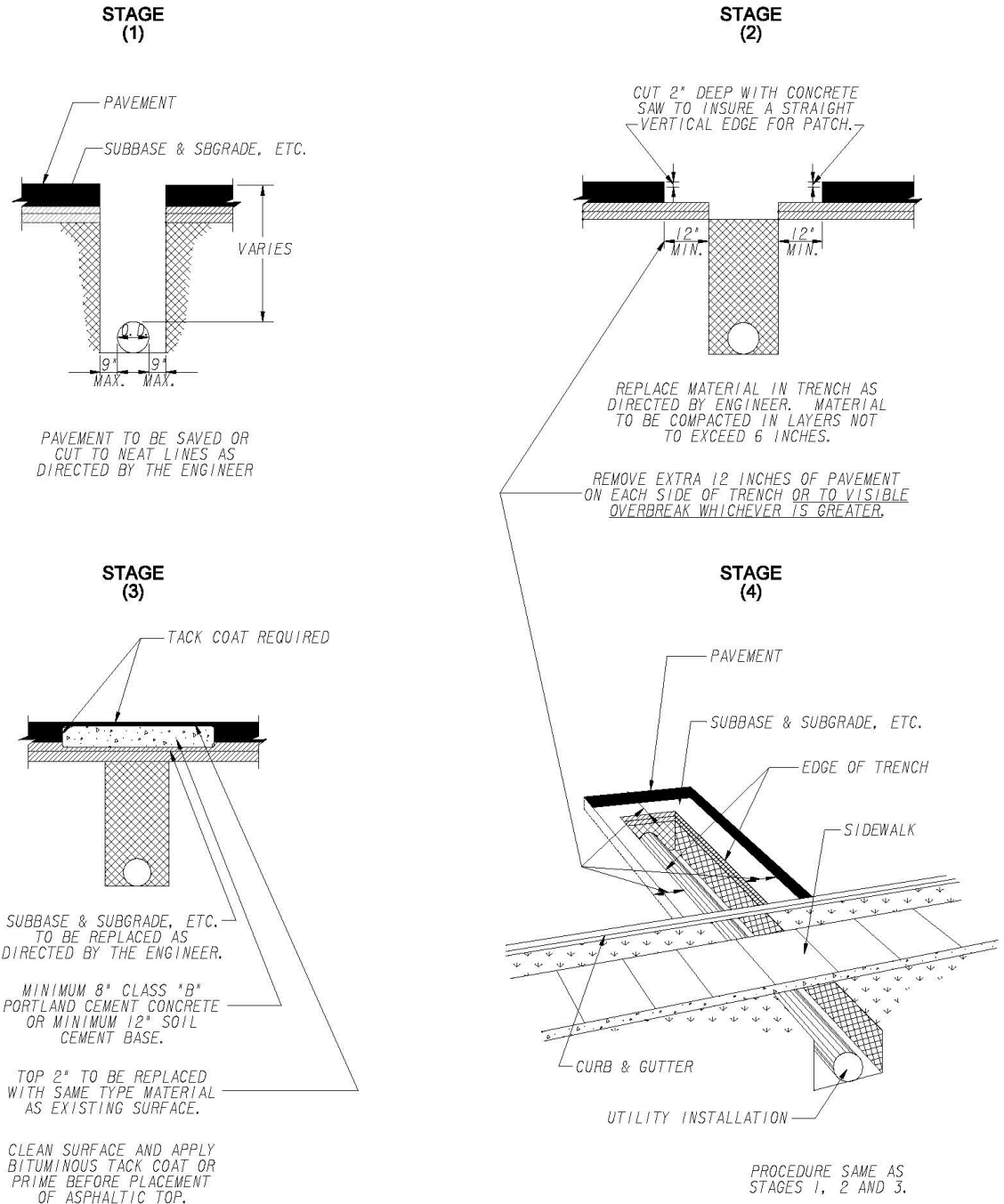

FIGURE 4

### 5.2.F.3. Trenchless Construction -

**5.2.F.3.a. Techniques** - Where there are few existing underground utility lines or for crossings of Interstate and Controlled Access highways, trenchless construction shall be considered. Trenchless techniques for installing utility facilities under a highway without disturbing the surface may include: driving, piercing, dry boring, horizontal directional drilling, auger and slurry boring, pipe jacking and tunneling, impact moling and ramming, and pipe bursting. These techniques shall follow the manufacturer's requirements and specifications. However, the Department may require additional special assurances or specifications for installations utilizing these methods.

**5.2.F.3.b. Controls for Trenchless Construction** - Controls for trenchless construction are as follows:

1. On Interstates and Limited Access Highways, trenchless construction shall be required for all crossings. Temporary access points (pits) will not be permitted in highway medians less than 100 feet wide (see Figure 5, Section 5.2.F.3.b.11 of this Manual). In addition temporary access points will not be permitted closer than 30 feet from the traveled way or within the roadbed structure. The State Utilities Engineer may grant an exception to the distances referenced above. The State Utilities Engineer must determine it to be in the public's interest and the Utility must show that the accommodation will not adversely affect safety, design, construction, operation or stability of the highway.
2. On all other highways, if at all possible, the temporary access points shall go from or beyond the ditch line in cut areas and beyond the toe of the slope in fill areas. The lateral dimension between the surfaced area of the highway and temporary access points shall be not less than 2 feet, if bulk-headed, and not less than 10 feet if not bulk-headed (see Figure 5, Section 5.2.F.3.b.11 of this Manual). The horizontal distance from the shoulder point to the edge of the boring pit shall be not less than the vertical distance from the shoulder point to the

bottom of the boring pit.

3. Backfilling of temporary access points shall be compacted to at least 95% of the maximum laboratory dry density to within 1 foot of the top of the embankment. Compact the top 1 foot of the embankment to at least 100% of the maximum laboratory dry density. Special backfill material may be required to achieve 100% compaction. The maximum laboratory dry density will be determined from representative samples of the compacted material using GDT 67. For reference, see the Department's Standard Specifications, current edition, Section 208.
4. Where unstable soil conditions exist, boring or tunneling operations shall be conducted in such a manner as not to be detrimental to the roadside being crossed. Soil coring indicating the type of subsurface material and verifying the absence of rock may be required.
5. If an obstruction (such as rock) is hit during construction and the bore is to be abandoned, the void shall be grout filled immediately. Abandoned casings shall be backfilled with grout as well.
6. The use of water under pressure (jetting) or puddling will not be permitted to facilitate boring, pushing, or jacking operations. Horizontal directional drilling using approved drilling fluids, such as bentonite, may be used in accordance with Intelligent Horizontal Directional Drilling guidelines.
7. For horizontal directional drilling, the utility shall furnish, in addition to permit plan requirements in Chapter 3 of this Manual, a bore plan (utilizing supporting calculations including bore planner software such as Vermeer's Atlas Bore Planner or equivalent) showing the proposed methods for the installation of Interstate or Limited Access crossing directional bores. No directional boring work will be allowed until the utility's submitted plan is approved by the State Utilities Engineer. This plan shall include, but is not limited to, the following:
  - Boring machine type and model
  - Proposed alignment of bore both horizontally and

vertically. Boring will not be allowed in select backfill areas such as at mechanically stabilized wall locations.

- Location of all proposed boring entry and exit pits
  - Cross sections of the existing ground
  - Entry angle (%) with respect to horizon
  - Plan shall show the rod cover (inches)
  - Rod selection:
    - Diameter (inches)
    - Rod length (feet)
    - Bend (feet radius) limit
  - Tooling:
    - Pilot bit diameters (inches)
    - Reamer diameter (inches): the diameter of the reamer shall not exceed 1.5 times the diameter of the product bundle installation
    - Identify soil type/mud factor – sand, gravel, cobble rock or same mixed with clay or reactive shale
  - Product bundle:
    - Diameter (inches)
    - Quantity
    - Bend (foot radius)
  - Sonde:
    - Ascending limit
    - Descending limit
8. The minimum depth of cover under travel lanes or the paved shoulder shall be 10 feet on Interstates and Limited Access Highways and shall be 4 feet on all other highways, streets or roads.
9. The installation shall include a locatable conduit system, with identification markers on each side of the Department's right-of-way.
10. The utility shall continuously monitor the location and alignment of the pilot drill progress to insure compliance with the proposed installation alignment and to verify depth of the bore. Monitoring may be accomplished by computer generated bore logs which map the bore path based on information provided by

the locating/tracking system. Readings or plots shall be obtained on every drill rod, and shall be provided to the Inspector on a daily basis. Upon completion of the bore, the utility may be required to furnish an as-built drawing along with a report of the monitoring of the drilling fluids during the pilot hole and back reamed hole, if available.

11. Excess drilling fluids shall be contained at the entry and exit points until recycled or removed from the site. The utility shall ensure that all drilling fluids are disposed of in a manner acceptable to the appropriate Local, State and Federal regulations. The utility's work will be immediately suspended by the Inspector whenever drilling fluids seep to the surface other than in the boring entrance or exit pit, or when a paved surface is displaced. The utility shall then propose a method to prevent further seepage and/or displacement, and shall remove and dispose of any drilling fluid, slurry and soil from the paved surface prior to resuming the boring operation.

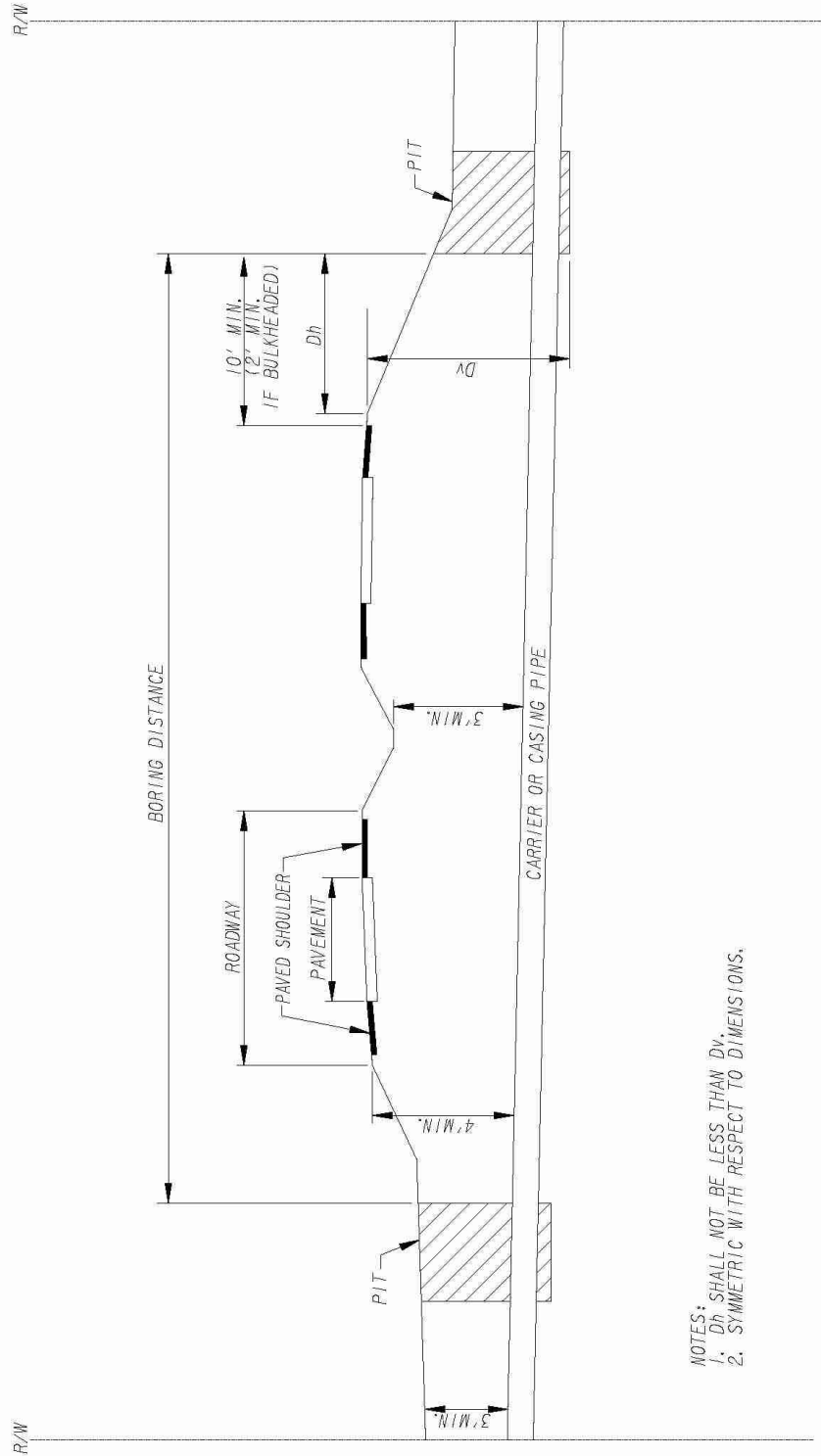

NOTES:  
 1.  $D_h$  SHALL NOT BE LESS THAN  $D_v$ .  
 2. SYMMETRIC WITH RESPECT TO DIMENSIONS.

DETAIL FOR BORING OR TUNNELING

FIGURE 5  
 NOT TO SCALE

### **5.3 EXISTING FACILITIES RETAINED UNDER PAVEMENT**

The Department's policy is that existing utility facilities, currently not under pavement, will not be located under the new pavement once the project is completed (i.e. widening project constructing new travel lanes). However, exceptions may be granted to this policy on a case by case basis, when the criteria from the Retention Request form (see GDOT's Utilities webpages) in Section 2.8.B of this Manual are approved. The Department realizes that with this exception comes the need for potential pavement cuts to repair facilities due to leaks, service connections, etc. These types of repairs or connections may require the Special Provision, Section 205, Roadway Excavation - Test Holes (see GDOT's Utilities webpages), as per Section 5.2.F.2.c of this Manual. Also, with this exception, comes the responsibility to the Utility to protect the travelling public and the integrity of the roadway system.

**5.3.A. General Considerations** - Utilities shall be responsible to permanently patch any pavement cut and maintain this patch should it become settled, cracked, broken or otherwise faulty. Permanent patching of pavement cuts shall be performed as soon as practical. "As soon as practical" should be within two weeks of the time of the actual pavement cut, weather permitting. It is also required that permanent patching complies with Section 5.2.F.2 of this Manual.

**5.3.B. Controls** - The following controls are for pavement cuts due to emergency repairs or new service connections:

1. No oblique pavement cuts will be allowed.
2. The repair of the pavement due to an emergency repair or new service connection shall be replaced as per Section 5.2.F.2 guidelines.
3. Concrete pavement cuts exceeding 60 square feet will require reinforcing steel. Number three (#3) re-bar at 12 inches on center at a minimum 1 ½ inch clearance from the bottom of the concrete slab.
4. Overlays/milling and inlays will match existing cross slopes and will be made in accordance to Department's Construction Standard Specifications, current edition.
5. Any exceptions will be granted on a case by case basis by the State Utilities Engineer.
6. Test Holes in the pavement due to an emergency repair or new service connections shall follow the guidelines as per Section 5.2.F.2.c.

## **5.4 MANHOLES**

The following guidelines are to be followed in treating manholes along the Department's road-widening and resurfacing projects.

### **5.4.A. Widening Projects (Manholes Currently Outside Existing Pavement)** - This is where manholes are located outside the existing pavement, but will be within the new pavement. (Includes new travel lanes, acceleration and deceleration lanes constructed under commercial driveway permits.)

1. Manholes will be relocated outside the limits of the new pavement whenever practical. (See Sections 2.8.B and 5.3 of this Manual.) The State Utilities Engineer must approve any manhole to be retained in the pavement.
2. If a retention request is granted, then all manhole covers will normally be paved over during construction. When adjustments are required, the manhole frame should be set at least 6 inches below pavement grade. Prior to paving over the manhole, the Utility should ensure the stability of the manhole so that it will not move under traffic loads and cause pavement failure. The Department's Project Engineer will confirm that the manholes have been inspected by Utility and that they are stable before paving begins.
3. Side entry tunnels may be constructed to high activity manholes depending on the distance and size of the manhole. Side entry should be used even though it may be necessary to enlarge and center rack the manholes. Plans should show where tunnels are proposed and the following data must be furnished for each manhole to assist in evaluation of proposals:
  - a. Size of manhole, number of ducts and description of its use
  - b. Number and size of cables and other equipment
  - c. Estimated annual activity.
4. Prior to the paving operation, the Utility should make sure that cables are air tight and take any other reasonable steps to eliminate the future need to enter the manholes through covers in the pavement.
5. If the retention request is approved, adjustment of manholes to grade will be permitted, a GUPS permit from the Department will be required before any work is done. The requested adjustments must be reviewed by the State Utilities Engineer before the permit is issued. The method of raising the manholes to grade as the "Approved Manhole Method" by the Department. (See Section 5.4.E of this Manual.) Manholes should not be adjusted to final grade until after the final surface paving is completed.



6. After a widening project has been completed, a permit will be required to cut the pavement over a manhole. The permitting will be handled in the following manner:
  - a. When manholes are to be entered to pull new cables into the duct system, the proposed treatment of each manhole whether it will be paved back over or raised to grade will be addressed in the permit (i.e. requesting to add the new cable).
  - b. When manholes are to be entered for any other purpose, the proposed treatment for each manhole will be addressed in the required permit for pavement cuts.
  - c. In emergencies, a permit will not be required at the time of the emergency. (See Section 3.9 of this Manual for requirements.) For removal of the asphalt, (see Section 5.4.E.2 of this Manual). For replacement of the asphalt, the surfaces of the area to be patched will be tacked before hot asphaltic pavement is placed and compacted in the patch. The mix will be placed in lifts not exceeding 2 inches and compacted. Final surface will be smooth and at grade with the surrounding pavement.

**5.4.B. Widening Projects (Manholes Currently in Existing Pavement Area)** - This category is where manholes are located in the outside lane of the existing pavement but may be within an inside lane upon completion of the project.

If the Utilities would like to retain the existing facilities, a Retention Request form (see GDOT's Utilities webpages) shall be submitted to the District Utilities Engineer. (See Section 2.8 of this Manual.) If the State Utilities Engineer approves the request, retained facilities will be treated the same as those mentioned in Section 5.4.A of this Manual. The State Utilities Engineer must give final approval of the treatment to manholes on widening projects.

**5.4.C. Resurfacing Only Projects** - This category covers where manholes currently are in the existing pavement and the roadway is to be resurfaced only, without milling or widening.

The District Utilities Engineer will notify the Utility of a planned resurfacing project. The Utility will determine which manholes and valves to either restore to grade, as per the "Approved Manhole Method", or leave under asphalt.

1. All types of manholes will be paved over during the resurfacing project. The Utility, at its option, may raise manholes to final grade using the "Approved Manhole Method" during the time of the project by including a request with their submitted permit including the Utility Adjustment Schedule (UAS); and in response to the District Utilities Engineer project notification letter.
2. Prior to the resurfacing operation, the Utility should make sure that cables are air tight and take any other reasonable steps to eliminate the future need to enter the manholes through covers in the pavement. The manhole covers should be checked for stability before resurfacing to insure that they will not move under traffic loads and cause pavement failures. The Project Engineer will confirm that the covers have been inspected by the Utility before resurfacing begins.
3. To ensure no pavement failures, the Department may require the Utility to adjust certain manhole frames and covers to grade utilizing the "Approved Manhole Method" when a manhole will not have enough asphalt cover.

**5.4.D. Milling and Resurfacing Projects** - This category is where the roadway surface will be milled and repaved without widening.

As soon as the State Maintenance Office determines what highways will be milled and resurfaced for the next paving season, they should forward this information to the District Utilities Engineer. The District Utilities Engineer will notify the Utility of a planned resurfacing project and request detailed information on their existing facilities. Upon receipt of the Utility information, the District Utilities Engineer will create a table with the Utility owner's name, type of facility and quantity, listing the number of manholes, valve covers, or other utility facilities that will require adjustment due to the milling and resurfacing or reconstruction/full depth projects and any other pertinent information necessary for the State Maintenance Office to prepare the contract documents.

There are three different cases in this category that determine if manholes and valves will need to be lowered and raised or if information is included in the contract instructing the Contractor to work around the manhole(s).

**5.4.D.1. Case I: Existing Concrete Manhole (Milling & Replacing Same Grade)** - This case is where the existing manhole was constructed utilizing a "Barton-Southern" style manhole (see Detail 1, at the end of Section 5.4.E.3.e) with a concrete-squared section (of various size) on the surface surrounding the top of the ring or frame. The

Utility will not be required to lower any concrete-square manholes which may be in conflict if the following conditions exist:

- a. The existing “Barton-Southern” style manhole is in good condition, with the concrete surrounding the manhole having no major cracking, spalling, looseness or otherwise unsound.
- b. The depth of the asphalt being milled is being replaced.
- c. Traffic can be maintained without lowering the manhole during the operations.

If the above conditions exist, then a Special Provisions shall be prepared by the State Maintenance Office and incorporated into contract stating that the Contractor will work around the manhole(s) listed using other appropriate methods, e.g. hand milling.

If any of the above conditions do not exist, the Utility will be required to lower and raise this type of concrete-square manholes as per the “Approved Manhole Method”.

**5.4.D.2 Case II: Existing Concrete Manhole (Milling & Replacing Different Depth Finish Grade)** - In this case the existing manhole was constructed utilizing a “Barton-Southern” style manhole (see Detail 2, at the end of Section 5.4.E.3.e) with a concrete-squared section (of various size) on the surface surrounding the top of the ring or frame. The milling operation will remove more asphalt than the paving operation will replace; the Utility will be required to lower any concrete-square manholes which may be in conflict as per the “Approved Manhole Method”.

**5.4.D.3 Case III: Existing Asphalt Manhole** - For this case, the Utility will be required to lower any standard manholes (see Detail 3, at the end of Section 5.4.E.3.e) that has asphalt surrounding the ring or frame, that will be in conflict with the milling of road surface as per the “Approved Manhole Method”. The Utility will determine which manholes to either restore to grade or leave under asphalt.

**5.4.E. Reconstructing Manholes “Approved Manhole Method”** - The following guidelines are for lowering and raising manholes of the concrete-squared type, asphalt type, and new manholes under all three Cases listed above which are, or will be, located within the pavement.

#### 5.4.E.1. Lowering the Manhole -

- a. Remove the asphalt from the manhole cover and the lip of the manhole frame. The Utility's personnel will have pre-marked the cover's position. At this time, the set of the cover within the frame will be checked and the following actions taken:
  1. If the cover is worn so that it is not level with the top of the frame, the existing frame and cover are to be removed and replaced with a new frame and cover equipped with a gasket.
  2. If the cover can be made to rock within the frame due to uneven wear of the contact surfaces, either the frame or cover or both shall be replaced as in (1) above.

If neither condition (1) nor (2) exists, continue with Step b.

- b. Remove a 30 inch area surrounding the manhole ring (unless removing the Barton-Southern style manhole then the entire section of concrete must be removed) and excavate to a solid surface below the base of the frame. This solid surface may be either compacted fill or concrete. The depth of the excavation is determine based on the frame height plus two 3 inch ring risers at all points.

The jack hammer is used to extend the vertical cut down to the solid surface. Ensure that no undermining of the existing surface occurs.

All asphalt, concrete, and fill are removed from this excavation. Loose material is shoveled and finally blown out with an air hose.

**CAUTION:** Do not undermine the existing asphalt. The wall is to be vertical, not sloped. Undermining will cause the existing asphalt to crack with time. Sloping will cause varying thicknesses in the concrete and create uneven stresses.

- c. Remove the cover and lift the existing frame off the surface on which it rests. Remove all loose mortar, loose bricks, and other material from this surface down to the required elevation until a solid base is attained both in the excavation and beneath the existing frame.
- d. Replace the frame measuring to the finish grade to verify that the correct depth has been attained with the addition of the two 3 inch rings. If the original frame is to be used, the frame shall be wire brushed or sandblasted until all rust and debris has been removed. Small pieces of concrete or asphalt bonded to the

frame need not be removed if they withstand the brushing or sand blasting.

- e. Metallic shims shall be used under the manhole frame to level with the pavement. Using strings stretched across the pavement in both directions (both perpendicular to and parallel to the roadway); ensure that the level of the manhole matches the pavement.

NOTE: Any new manholes being constructed shall have ½ inch anchor bolts fastening the frame to the manhole.

CAUTION: No tolerance is permitted here.

The shims are to be cast iron, stainless steel, or hot dipped galvanized steel. They may be built up with flat plates made of the same material if necessary. Broken pieces of brick, rocks, or other material are not to be used as shimming material. The frame is to be shimmed in four locations only, at one point on each side of the frame, both perpendicular to and parallel to the roadway.

- f. Place and inflate an expandable tube inside the frame so that it seals off the open area between the underside of the frame and the surface on which the frame previously rested. This allows the collar to be poured at the same time the excavation is filled.
- g. Using a hand or machine operated tamping device, moisten the excavation and tamp the earth until it is tightly compacted.
- h. Pour Class “A” concrete cap a minimum of 12 inches in diameter around the entire manhole to a minimum depth of 12 inches in height; (see Detail 4, at the end of Section 5.4.E.3.e). Under no circumstance is the concrete to reach a height above the frame.

CAUTION: This is a critical step. The excavation must be moistened before concrete is placed to keep it from drawing water from the concrete and thereby contributing to defects in the concrete. Moisture also improves the tamping process. Tamping must be performed to insure a solid surface that will not settle when the concrete is placed.

Using trowels, work the concrete until it is level creating a smooth finish, leaving no depressions or ridges around the frame. This will require continual reworking due to the concrete will tend to flow downhill and must be worked until it holds its shape.

- i. Allow the concrete to cure as per the Department's Construction Standard Specifications, current edition.

CAUTION: Do not place concrete when the temperature is expected to drop below 40 degrees in the next 6 hours.

- j. Replace manhole lid and repair the roadway by temporary paving over the manhole until the milling and paving operation has been completed. Once this has been completed and smoothness testing has been approved by the Project Engineer, the manhole may be raised as per Section 5.4.E.2 of this Manual.

#### 5.4.E.2. Raising the Manhole

- a. Remove the asphalt 3 inches surrounding the manhole cover and the lip of the manhole frame. The Utility's personnel should have pre-marked the cover's position. All loose asphalt is to be removed from this excavation. Loose material shall be shoveled and finally blown out with an air hose.
- b. Remove the manhole lid and thoroughly clean the frame around the area where the lid sits; then install two 3 inch Steel Locking Rings (see Detail 4, at the end of Section 5.4.E.3.e), from East Jordan Iron Works or equivalent. It is vital that the manufacturer's instructions for the installation of the rings be closely followed. According to the manufacturer, with proper installation, this item is capable of dampening traffic loads, dissipating vibrations and reducing water infiltration.

For future resurfacing projects of these manholes, the Utility will only remove the Steel Locking Rings as necessary to allow for the milling and paving operations and add rings as appropriate to bring to final grade, (see Section 5.4.E.3 of this Manual).

Note: In non-traffic lane situations the Utility can use the non locking steel rings.

- c. Replace the manhole lid, and then fill the crevice around the rings with epoxy asphalt (example Perma-Patch) as necessary, using a hand or machine operated tamping device to ensure no voids exist.

- #### 5.4.E.3. Lowering and Raising Ring Risers -
- Before this work can begin, a determination needs to be made on the depth of the milling and the thickness of how much asphalt is being replaced. If the milling operation is less than 3 inches only one Steel Locking Ring will be removed. (For example, the Steps a through e below are based on

the milling and inlay depth of 2 inches. If the depth of the milling and inlay is greater additional rings will be required).

- a. Remove the asphalt 3 inches surrounding the Steel Locking Ring down to the lip of the second Steel Locking Ring. The Utility's personnel should pre-mark the cover's position. All loose asphalt is to be removed from this excavation. Loose material shall be shoveled and finally blown out with an air hose.
- b. Remove the manhole lid and the first Steel Locking Ring; then thoroughly clean the second Steel Locking Ring around the area where the manhole lid will be replaced. Replace the manhole lid and repair the roadway by temporarily paving over the manhole until the milling and paving operation has been completed. Once this has been completed and smoothness testing has been approved by the Project Engineer, the manhole may be raised.
- c. To raise the manhole that has been paved over, remove the new asphalt from the manhole lid to a distance of 3 inches surrounding the manhole cover and the lip of the second Steel Locking Ring riser. The Utility's personnel should have pre-marked the cover's position. All loose asphalt is to be removed from this excavation. Loose material shall be shoveled and finally blown out with an air hose.
- d. Remove the manhole lid and again thoroughly clean the frame around the area where the lid sits, re-install one 3 inch Steel Locking Rings, from East Jordan Iron Works or equivalent (if the milling operation depth was greater than the repaving depth, the height of the ring riser will change). It is vital that the manufacturer's instructions for the installation of the rings be closely followed. According to the manufacturer, with proper installation, this item is capable of dampening traffic loads, dissipating vibrations and reducing water infiltration.
- e. Replace the manhole lid, and then fill the crevice around the rings with epoxy asphalt (example Perma-Patch) as necessary, using a hand or machine operated tamping device to ensure no voids exist.

\* NOTE: REFERRED TO AS 'BARTON-SOUTHERN' STYLE MANHOLES WHEN DEALING WITH AT&T/BELLSOUTH FACILITIES, BUT OTHER UTILITIES MAY HAVE CONSTRUCTED SIMILAR TYPE MANHOLES, BUT TYPICALLY ON A SMALLER SCALE.

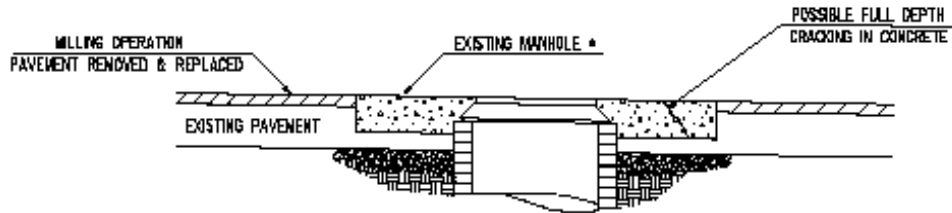

CASE I: EXISTING CONCRETE MANHOLE  
MILLING & REPLACING SAME GRADE

CONDITION 1: MILLING OPERATION: REMOVE AND REPLACE ASPHALT AT THE SAME DEPTH.

CONDITION 2: THE EXISTING MANHOLE IS IN GOOD CONDITION WITH NO CRACKS, SPALLING, ETC. IN THE CONCRETE SURROUNDING THE MANHOLE.

CONDITION 3: TRAFFIC CAN BE MAINTAINED WITHOUT LOWERING THE MANHOLE DURING THE OPERATIONS.

IF ALL 3 OF THE ABOVE CONDITIONS ARE MET, A NOTE WILL BE PLACED IN THE PLANS GIVING THE NUMBER OF MANHOLES THE CONTRACTOR WILL MILL AROUND. IF ANY OF THE ABOVE CONDITIONS FAIL THE MANHOLE WILL BE LOWERED AND RAISED UTILIZING THE 'APPROVED MANHOLE METHOD' (SEE DETAIL 4).

DETAIL 1  
NOT TO SCALE

\* NOTE: REFERRED TO AS 'BARTON-SOUTHERN' STYLE MANHOLES WHEN DEALING WITH AT&T/BELLSOUTH FACILITIES, BUT OTHER UTILITIES MAY HAVE CONSTRUCTED SIMILAR TYPE MANHOLES, BUT TYPICALLY ON A SMALLER SCALE.

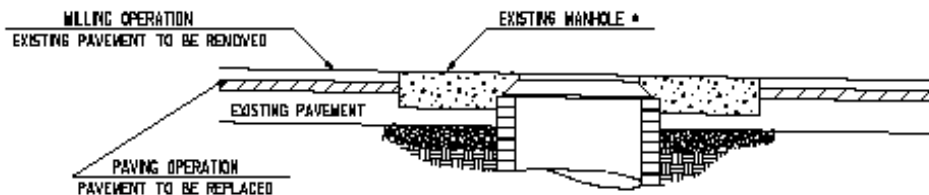

CASE II: EXISTING CONCRETE MANHOLE  
MILLING & REPLACING DIFFERENT DEPTH FINISH GRADE

CONDITION 1: MILLING OPERATION: REMOVING A DEEPER DEPTH OF ASPHALT THAN THE PAVING OPERATION WILL REPLACE. THE MANHOLE WILL BE LOWERED AND RAISED UTILIZING THE 'APPROVED MANHOLE METHOD' (SEE DETAIL 4).

DETAIL 2  
NOT TO SCALE



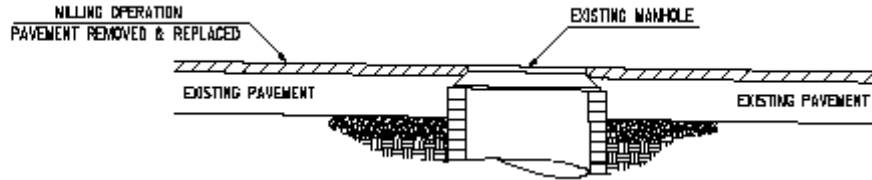

CASE III: EXISTING ASPHALT MANHOLE  
MILLING & REPLACING SAME GRADE

CONDITION 1: MILLING OPERATION WILL REMOVE AND REPLACE ASPHALT AT THE SAME DEPTH. THIS TYPE OF MANHOLE WILL BE LOWERED AND RAISED USING THE "APPROVED MANHOLE METHOD" (SEE DETAIL 4).

DETAIL 3  
NOT TO SCALE

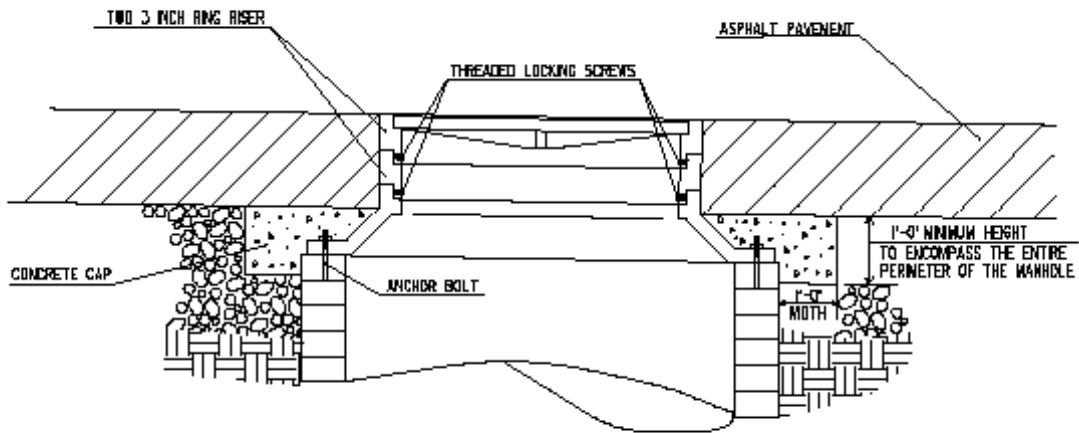

CASE IV: DIAGRAM OF "APPROVED MANHOLE METHOD"  
REQUIRED ON ANY NEW INSTALLATION OR WHEN EXISTING  
MANHOLES MUST BE LOWERED & RAISED

DETAIL 4  
NOT TO SCALE

- 5.4.F. Abandoned Manholes** - When approved for abandonment and prior to backfilling, the bottom of the structure shall be broken up in such a manner that water will readily pass through and all pipes entering the manhole shall be plugged or grout filled. The top portion of the manhole structure shall be removed in order to establish a minimum of 3 feet cover from subgrade or finish grade when not under the pavement; and filled with granular embankment (sand) or suitable backfill material that can readily meet the requirements of Section 208 of the Standard Specifications.

## **5.5 UTILITY TUNNELS AND UTILITY BRIDGES**

- 5.5.A. General Considerations** - A utility tunnel or utility bridge occasionally is provided for a pipeline or other facilities crossing a freeway at a strategic location. Where it can be foreseen that several utility crossings will be needed, the cost of the tunnel (either a large casing or a box culvert) or of the bridge may be less than that for the alternate of several untrenched or separately encased pipelines. Where it appears that these conditions exist, the Department will take steps as necessary to insure that adequate study is made by the utility companies to anticipate their needs for future crossings and to converge their facilities to a joint-use single crossing or increase the size of their facilities through the tunnel to meet the projected needs.

### **5.5.B. Controls -**

- 5.5.B.1. Tunneling Specifications** - Tunneling under any existing roadway shall be accomplished in accordance with the Standard Specifications, current edition, Section 555, Tunnel Liner. In addition to requirements in the Specifications, the Department requires the space between the utility carrier and the tunnel liner to be filled with a sand cement grout.

- 5.5.B.2. Isolation of Hazardous Materials** - In a combined tunnel or bridge, provisions shall be made to isolate mutually hazardous transmittants, such as fuels and electric energy, by compartmentalizing or by auxiliary encasement of incompatible carriers. The utility-tunnel or utility-bridge structure shall conform in appearance, location, bury, earthwork and markers to the culvert and bridge practice of the Department.

## **5.6 OVERHEAD POWER AND COMMUNICATION LINES**

**5.6.A. General Considerations** - The type of construction, vertical clearance above pavement, and location of poles, guys, and related ground-mounted utility appurtenances, such as transformers or wiring cabinets, are factors of major importance to preserve a safe traffic environment as well as the appearance of the highway and the efficiency and economy of highway maintenance. A critical requirement for locating poles, guys, and related facilities along the roadside is the width of the border area; i.e., the space between the edge of pavement, edge of paved shoulder or curb line and the right-of-way line, and its availability and suitability for accommodating such facilities. The safety, maintenance efficiency and appearance of highways are enhanced by keeping this space as free as possible from encroachment by obstacles above the ground. Where ground-mounted utility facilities are to occupy this space, they shall be placed as far as possible from the traveled way and beyond the clear zone. The nature and extent of roadside development and the ruggedness of the terrain are controlling factors for locating poles, guys and related facilities at the right-of-way line.

### **5.6.B. Controls for Overhead Facilities -**

#### **5.6.B.1. Types of Construction -**

- a. Longitudinal installations on the right-of-way shall be limited to single-pole structures.
- b. Only one pole-line will be permitted for longitudinal installation within a segment of the right-of-way or with operating clearance on the right-of-way unless proven impractical. Thus, joint-use shall be considered, as indicated by Rule 222 of Part 2 of the National Electrical Safety Code (NESC). This is of particular significance at locations where the right-of-way widths approach the minimum needed for safe operations or maintenance requirements or where separate installations may require extensive removal or alteration of trees. Dual pole lines are treated as exceptions that must be approved by the State Utilities Engineer.
- c. Crossings associated with longitudinal facilities shall be minimized with consideration given to: geometrics, service lines, safety and aesthetics. Repetitive crossings will not be permitted strictly to reduce clearing or easement requirements.

**5.6.B.2. Horizontal, Vertical, and Radial Clearances** - The clearances for power and communication lines shall conform to the current National Electric Safety Code (NESC) and the current AASHTO *Roadside Design Guide* applicable for the system, except where greater clearances are required as follows:

- a. **Horizontal** - See Section 5.6.B.3 and Chapter 8 of this Manual, for horizontal clearances.
- b. **Vertical** - The minimum vertical clearance above the roadway shall be 22 feet for electric lines, and 18 feet for communication and cable television lines. These clearances may be greater, as required by the National Electric Safety Code (NESC) and governing laws.
- c. **Radial** - A minimum radial clearance of 20 feet shall be provided from the nearest part of all bridge structures.
- d. **Overlashing** – When a new cable, fiber or other line is lashed or attached to an existing messenger wire or cable, factors that will be considered when reviewing overlashing requests are:
  1. All interstate and limited access rights-of-way crossings will be required to meet current policy of 18 feet minimum vertical clearance above the pavement.
  2. When a permit is requested to overlash an existing facility and the existing facility **does not** meet current NESC requirements, or the proposed facility to be overlashed will cause a violation of the NESC, the entire aerial crossing will be required to be upgraded to meet the vertical requirements of 18 feet above pavement.
  3. Overlashing to existing cables at current crossings that meet the NESC shall be exempt from the current policy on 18 feet minimum vertical clearance.

All other existing conditions not covered by case 1 through 3 above will require an exception request with the Utility's permit submittal and include verification that the aforementioned cases does not apply.

These clearances are in effect for installations beginning from the published date of this Manual.

**5.6.B.3. Longitudinal Installations -**

- a. The location of poles, guys, and related ground-mounted utility facilities on freeways and other highways having partial or full control of access are to conform to Section 2.5.B of this Manual.
- b. On conventional highways in rural areas, poles and related facilities are to be located as near as practical to the right-of-way line. As a minimum, the poles are to be located outside the clear zone.
- c. Utility obstacles shall be located with characteristic of traffic and the least obstructive for maintenance operations. The AASHTO *Roadside Design Guide's* (current edition) clear zone guidelines are to be used to determine the desired distance for above ground utility installations. Each permit will be reviewed to control new utility facilities from being installed in the shaded zones. (See Section 5.6.B, Figures 7 to 13 of this Manual). Unless greater distances are required from the above references, the desirable distance shall be 30 feet from the edge of pavement. When the Utility can demonstrate that these set back distances are not practical and accident data supports a safe roadside environment, the *Roadside Design Guide*, current edition, will be used as a guide in determining exceptions.
- d. Normally, utility pole lines should be constructed to avoid the outside of curves. Exceptions may be considered on a case by case basis when the utility company can show the impracticality of all other alternatives. The *Roadside Design Guide* will be used as a guide when evaluating exceptions when accident data supports a safe roadside environment.
- e. In keeping with the nature and extent of roadside development along roadways in urban areas, such facilities shall be located as near as possible to the right-of-way line and outside the clear zone. Where there are curbed sections the utilities are to be located as far as practical behind the face of curb. See below for the minimum lateral clearances and the respective posted speed limits:

<u>Minimum Lateral Clearance</u>	<u>Posted Speed Limit (mph)</u>
12'	45 greater
8'	$35 \leq x < 45$
6'	$< 35$

The lateral clearance is measured from the face of curb to the face of pole or facility. However, in all of the above cases, the facility shall not encroach upon current ADA sidewalk clearances; (see Examples 4 thru 6, on the following page).

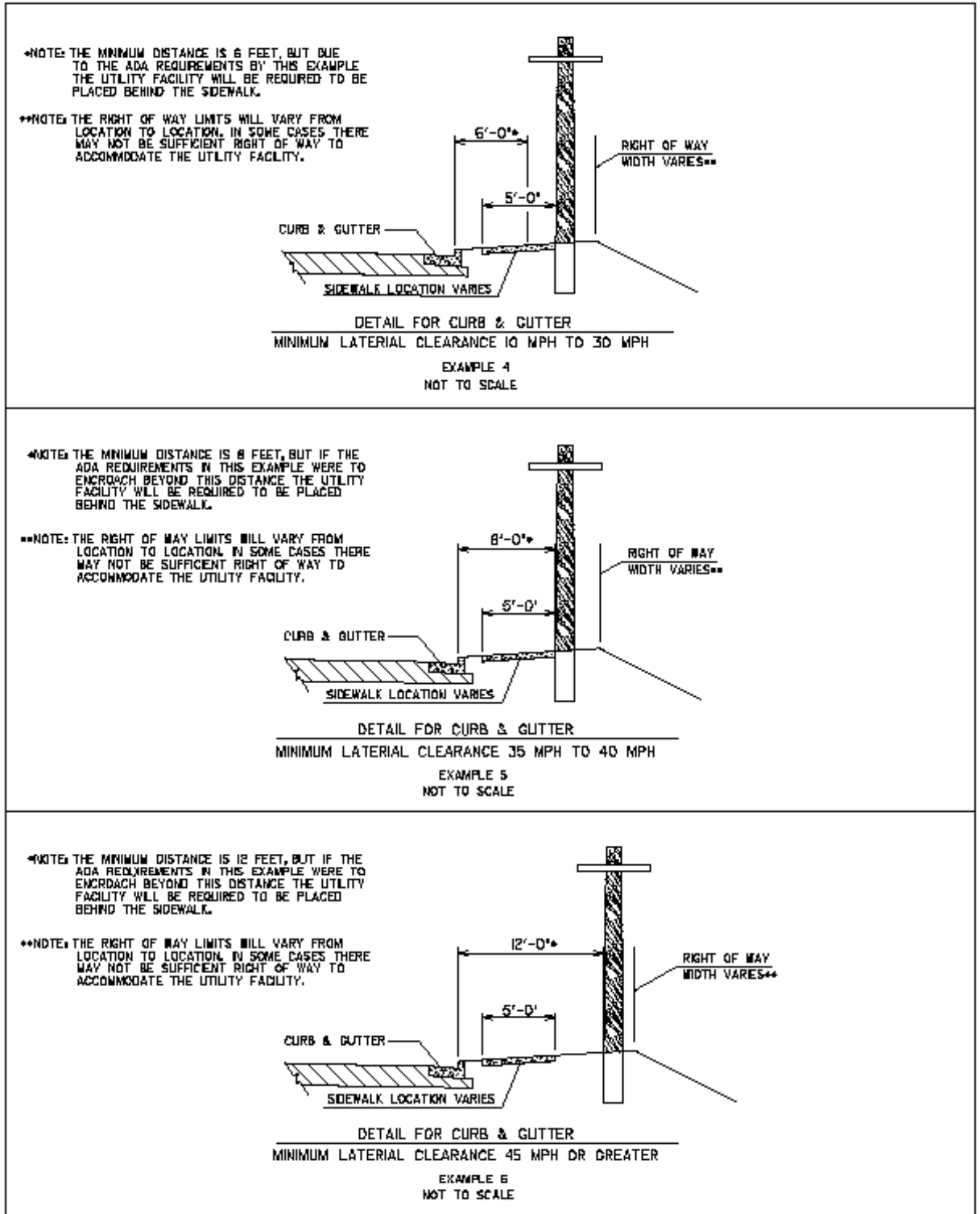

- f. The location of overhead utility installations on highways with exceptionally narrow right-of-way or on urban streets with closely abutting improvements or trees are special cases which must be resolved in a manner consistent with the prevailing limitations and conditions. The Department will work with the utility to determine an acceptable location based on roadway alignment, expected operating speed, and other design and environmental features of the highway or street. Before locating the utility at other than the right-of-way line, consideration shall be given to designs employing self-supporting, armless, single-pole construction with vertical arrangement of wires or cables, or other techniques that are permitted by governmental or industry codes and that are conducive to a safe traffic environment. Exception to standard clearances may be made where poles and guys can be placed at locations behind guard rails, beyond deep drainage ditches, on top of steep slopes, behind retaining walls, and other similarly protected locations.
- g. In general, pole(s) replacement in existing lines, or addition of mid-span poles, may be made to coincide with other existing poles along the street, except that additional setback may be required for single new poles being installed if there are advantages to be gained, (see Chapter 8 of this Manual), because of critical location, such as on curves or at intersections, and if the alignment can be satisfactorily arranged.
- h. Guy wires to ground anchors and stub poles shall not be placed between a pole and the traveled way where they encroach upon the clear zone.
- i. Where irregularly shaped portions of the right-of-way extend beyond the normal right-of-way limits, variances in the location from the right-of-way line shall be allowed as is necessary to maintain a reasonably uniform alignment for longitudinal overhead and underground installations.
- j. Longitudinal installations of poles, guys or other related facilities shall not be located in a highway median. On crossings of a highway, such facilities should not be located in a highway median less than 100 feet in width. Poles and other appurtenances for highway lighting may be located in the median if other alternatives are determined to be impractical and where adequate protection is provided to the highway user.
- k. Each permit will be reviewed to prevent new utility poles from being installed in the shaded control zones (see Figure 7 to 13 on the following pages) to the extent as possible.



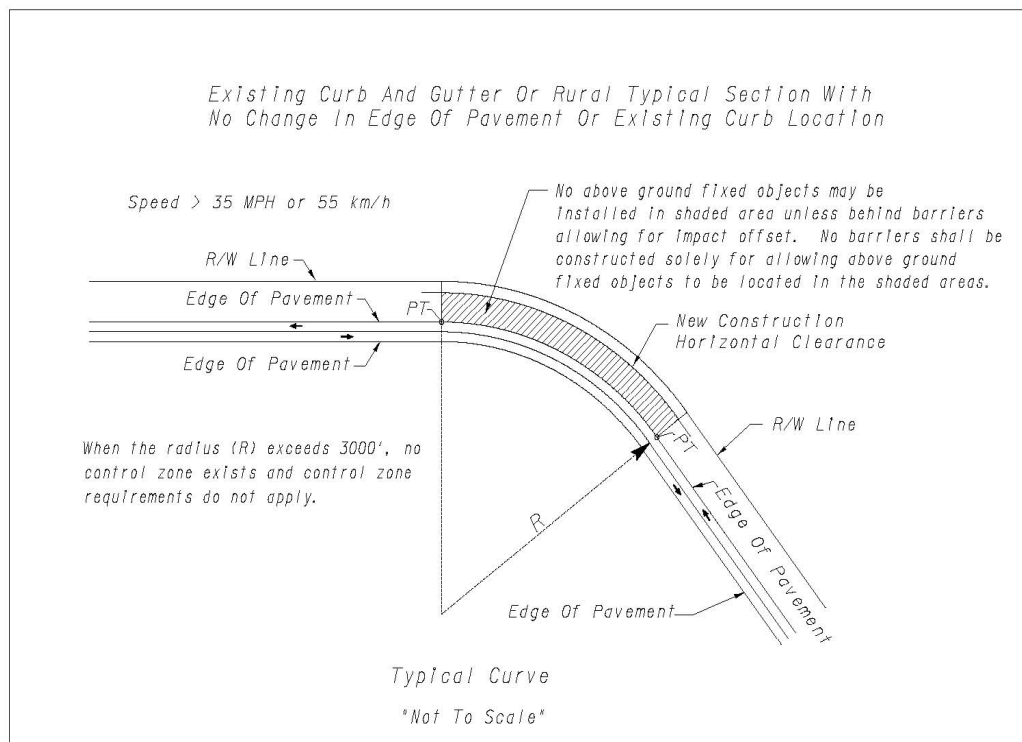
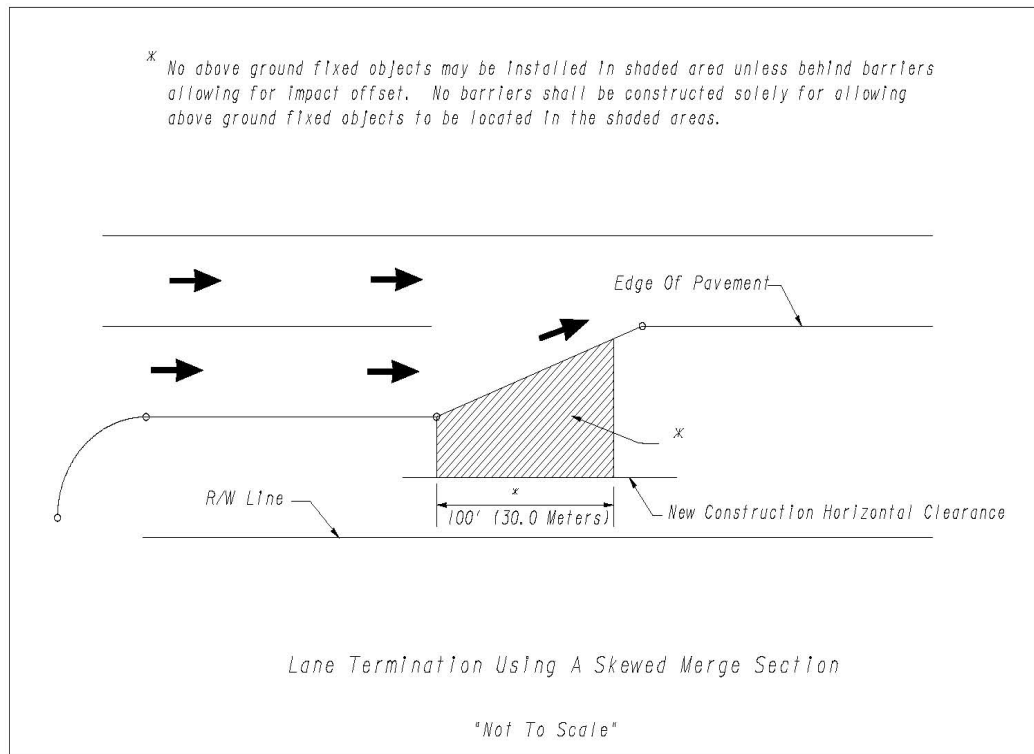

Fig. 7

As shown in Figure 7, poles on the outside of a curve usually have a higher exposure to vehicle impacts. This is particularly important for situations where there is a single curve after a long straight section of roadway or where one curve is substantially more severe than other curves which are in close proximity. However, for winding roadways with sequentially occurring curves in opposite directions, it would not normally be cost effective or desirable for the pole line to cross the road repeatedly in order to achieve the inside curve placement.

When a pole line is placed on the inside of a severe curve, e.g., a curve with a radius of less than 1700 feet, it may be necessary to place strain poles on the outside of the curve. These strain poles should be of a design criterion to meet National Cooperative Highway Research Program (NCHRP) 350 TL-2 design. Pole guys and strain poles should only be used if they can be designed in such a way that the fallen pole guy wire will not pose a hazard to traffic.



**Fig. 8**

Lane drops, deceleration lanes, kinks, tee-intersections, and sections where pavement narrows are several locations where poles should be avoided. This is especially important when it can be reasonably foreseen that an inattentive or physically impaired driver might not be able to accurately perceive these locations. Another cause of this problem is a traffic conflict, where a driver is prevented by another vehicle from changing lanes or moving laterally. If it is impractical to span these critical zones without a pole, consideration should be given to the use of a guardrail or crash cushion. These locations are common in areas where developers are required to build the ultimate cross section along their development. Figure 8 thru 12 shows locations of areas that poles would be vulnerable.

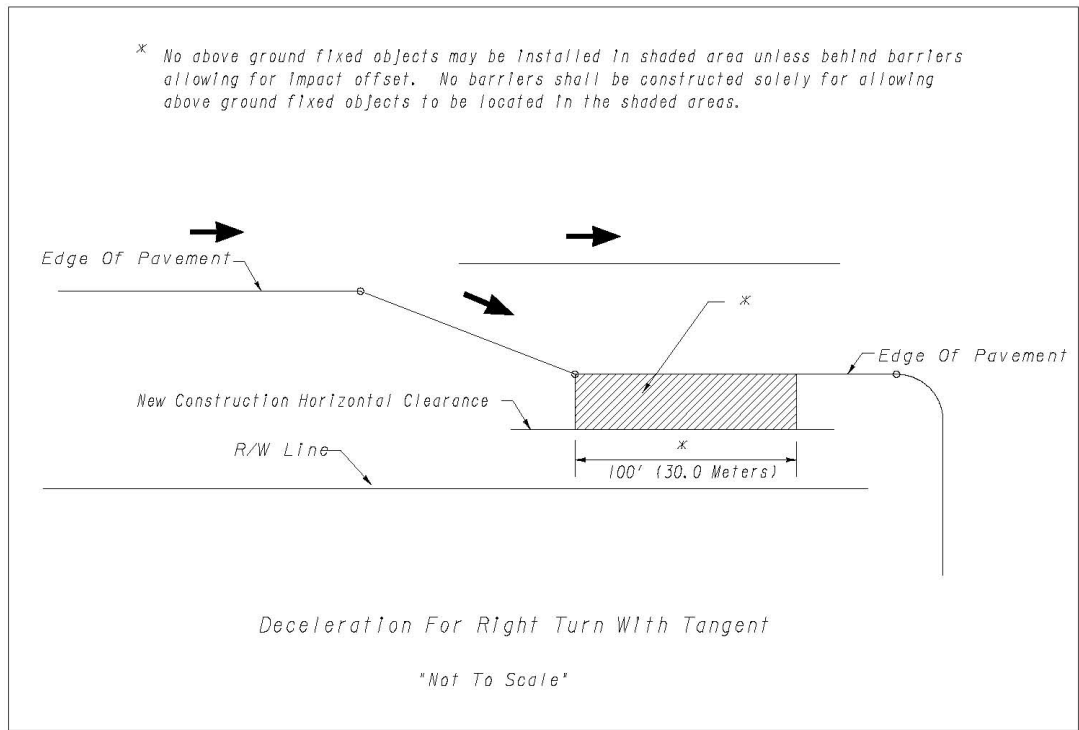

Fig. 9

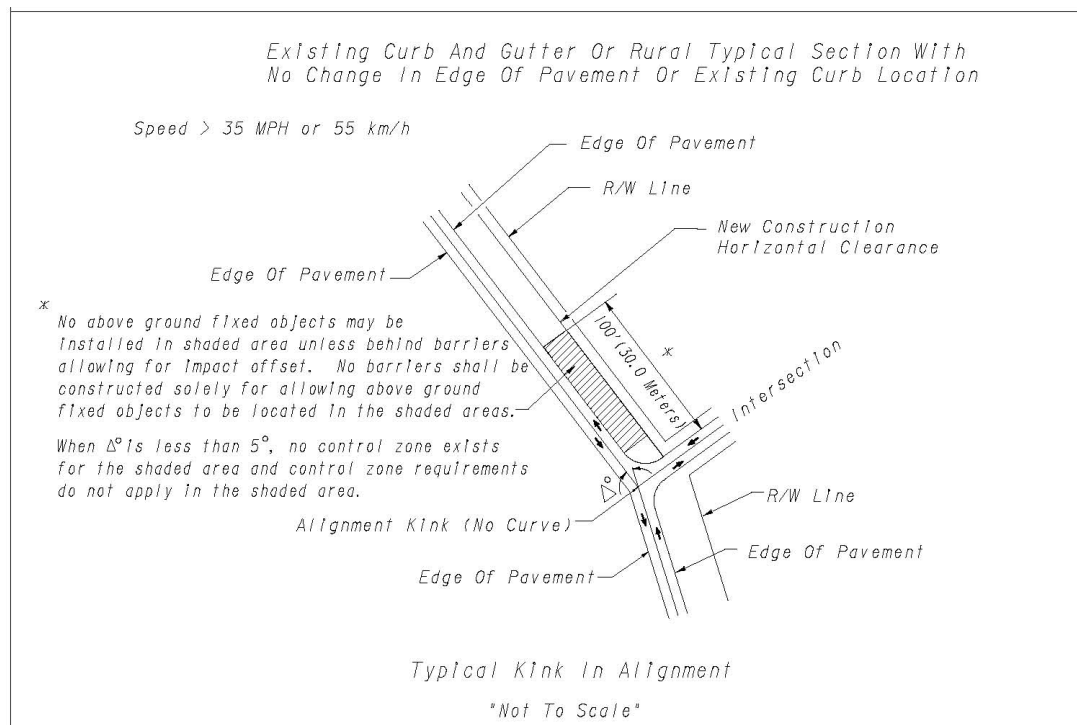

Fig. 10

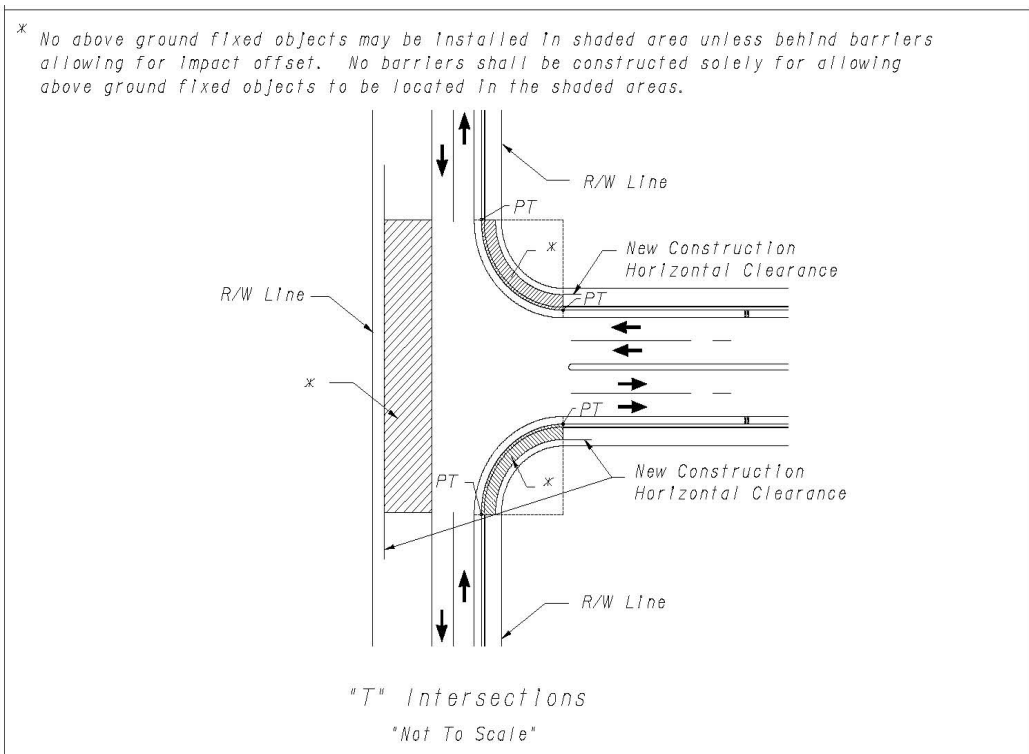

Fig. 11

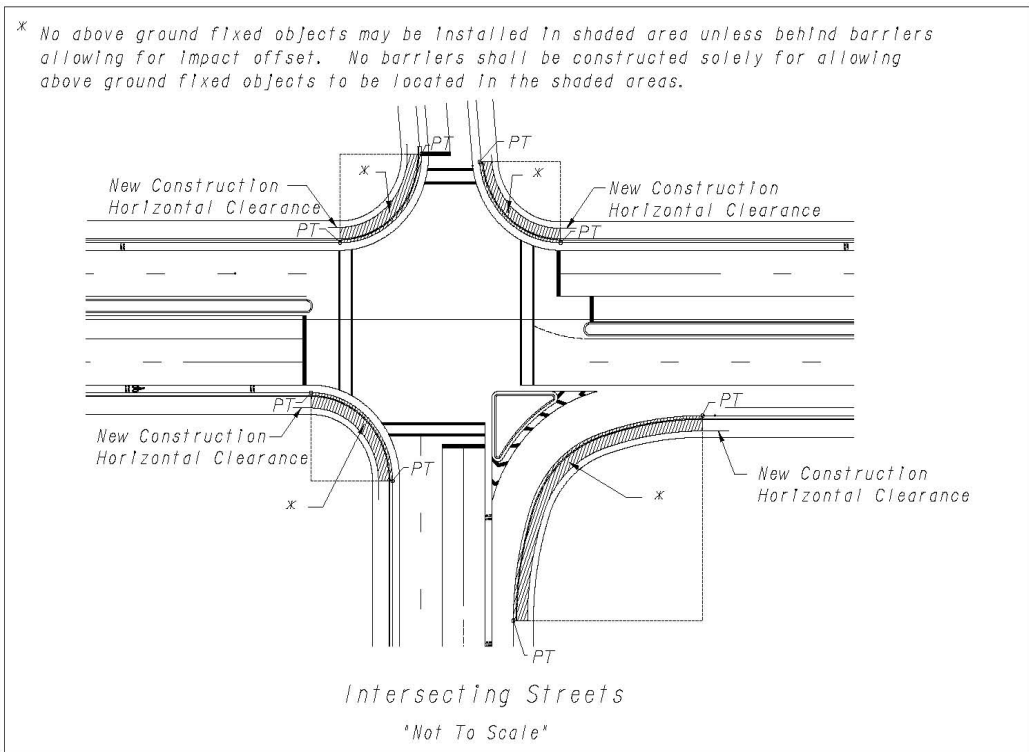
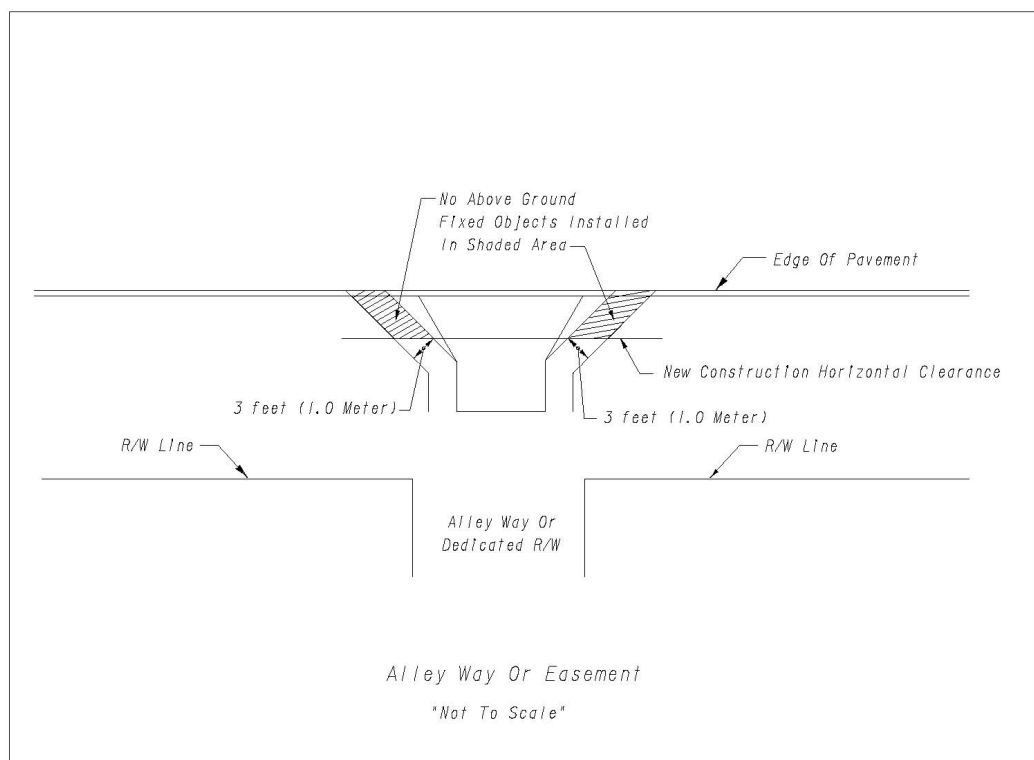

Fig. 12

Where critical traffic conflicts can be foreseen, especially at intersections of high-speed roadways, pole placement may be designed to avoid the most critical secondary collisions. For example, if the major roadway is north-south in direction and the minor roadway is east-west, the most critical quadrants for a secondary collision (collision of a vehicle with a pole after an initial two vehicle collision) are the northeast and southwest quadrants. Thus, the preferred placement for poles at this intersection would be the northwest and/or southeast quadrants, as shown in Figure 12.



**Fig. 13**

1. **Rural Shoulder** - For all new utility facilities, the provisions in this Manual will apply in full since there is a range of locations available for placement. Greater safety for the traveling motorist may be obtained with relatively little increase in cost for the utility.

**Clear Zone is greater than Right-of-Way** - In the situation where the clear zone limits is wider than the right-of-way, the Utility will not be permitted to install poles and/or above ground utility appurtenances within the right-of-way. The Utility may consider underground installation as an option.

If the Utility elects to install poles or above ground utility appurtenances that are outside of the right-of-way, the Department strongly encourages the Utility to consider placement of said poles and appurtenances so that the clear zone is maintained (see Figure 14).

Where the Utility feels that the normal clear zone limits are not practicable, the Utility bears the responsibility of demonstrating that alternative limits or treatments are more appropriate.

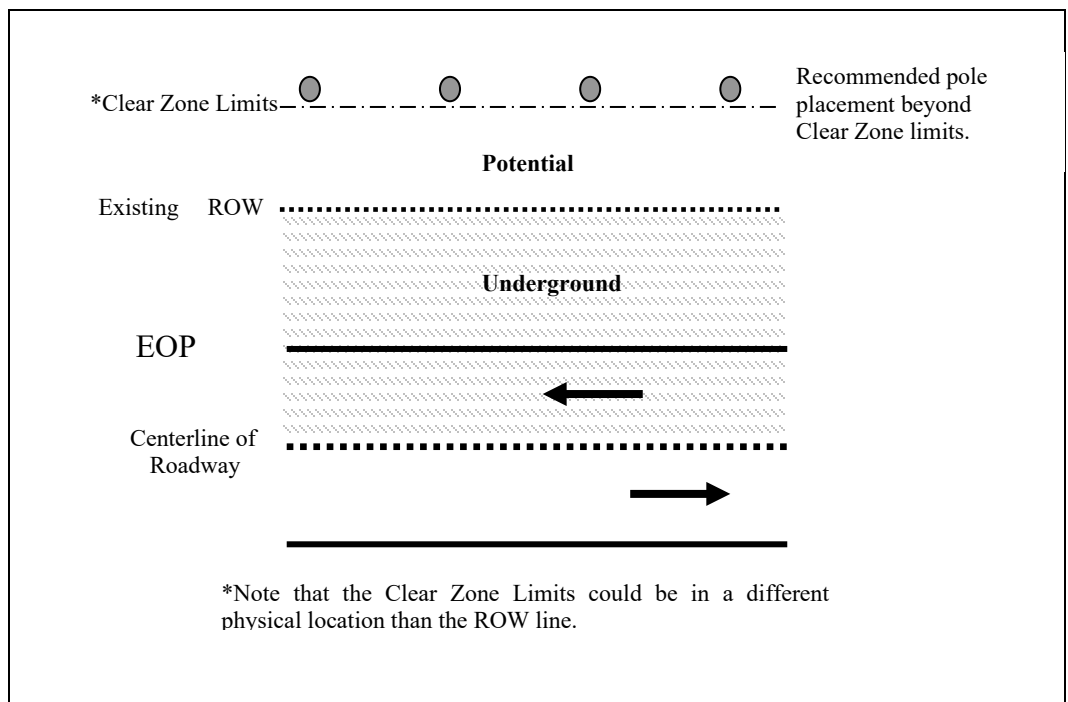

Figure 14

**Right-of-Way is greater than Clear Zone** - In the situation where the right-of-way is wider than the clear zone limits, the Utility may be permitted to install poles and/or above ground utility appurtenances within the right-of-way but will not be permitted to install any poles and/or above ground utility appurtenances within the clear zone limits (see Figure 15). The Utility may consider underground installation as an option within the clear zone limits.

Note: All utility facilities are to be installed at the back edge of the right-of-way. Exceptions to this policy may be allowed if other utilities occupy this location; in this case the facilities may be moved in a nominal distance as determined by the District

Utilities Engineer, also new pole line facilities may be moved in from the back of the right-of-way line to remove the need for additional easements off the right-of-way. In both cases this distance will be determined based on the clear zone limit and right-of-way width.

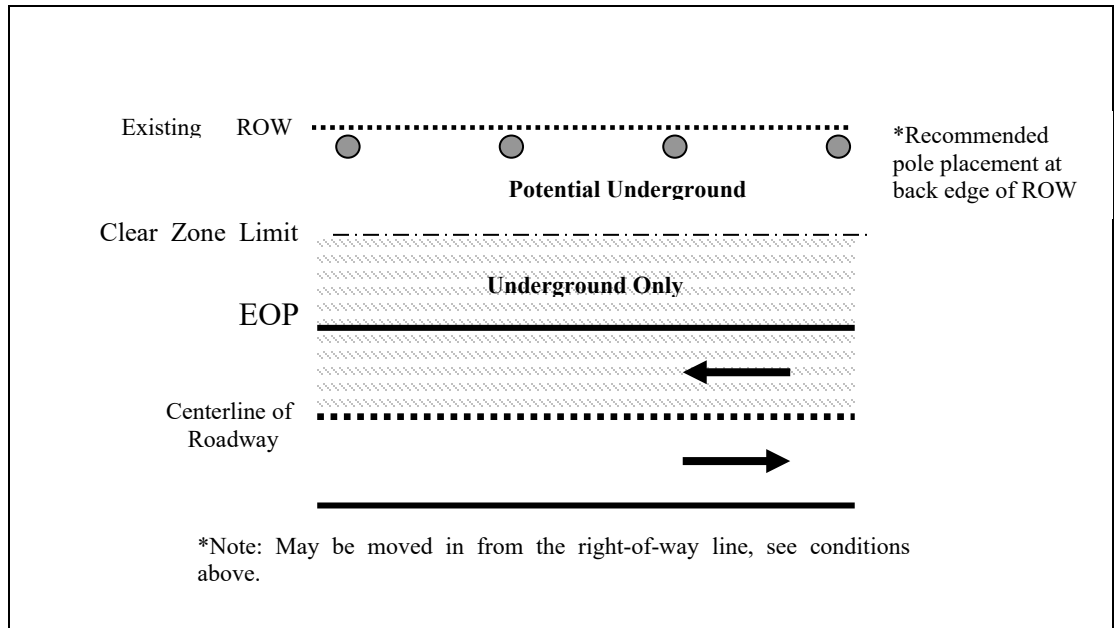

Figure 15

- m. **Urban Shoulder/Curb Section** - In keeping with the nature and extent of roadside development along roadways in urban areas, such facilities shall be located as near as possible to the right-of-way line and outside the clear zone limits. Where there are curbed sections the utilities are to be as far as is practical behind the face of curb, preferably behind the sidewalk area. A lateral clearance of 12 feet from face of curb to face of pole is required. On roadways where the posted speed limit meets or exceeds 35 mph but is less than 45 mph, a lateral clearance of 8 feet from face of curb to the face of pole is required. On roadways where the posted speed is less than 35 mph, a lateral clearance of 6 feet from face of the curb to face of pole is required.

The location of overhead utility installations on highways with exceptionally narrow right-of-way or on urban streets with closely abutting improvements or trees are special cases which must be resolved in a manner consistent with the prevailing limitations and conditions. The Department will work with the

utility to determine an acceptable location based on roadway alignment, expected operating speed, and other design and environmental features of the highway or street. Before locating the utility at other than the right-of-way line, consideration shall be given to design employing self-supporting, armless, single-pole construction with vertical arrangement of wires or cables, or other techniques that are permitted by governmental and industry codes and that are conducive to a safe traffic environment. Exceptions to standard clearances may be made where poles and guys can be placed at locations behind existing guardrail, beyond deep drainage ditches, on top of steep slopes, behind retaining walls, and other similarly protected locations.

Guy wires to ground anchors and stub poles shall not be placed between a pole and the edge of pavement where they encroach upon the clear zone.

**5.6.B.4. Highway Crossings** - When the location of poles or other support structures for lines crossing the right-of-way will be outside the right-of-way the following shall apply:

- a. The Department will review its Construction Work Program and determine if the proposed installation is in conflict with an active project (i.e the right-of-way has been established). A permit shall be issued if it is determined that there is no conflict. The Utility shall clearly show on the plans the minimum vertical clearance above the roadway.
- b. If it is determined that there is a conflict with an active project, then the utility should agree to install their facilities beyond the limits of any proposed (additional) right-of-way which is required for the active project. It would be in the best interest of both parties as well as the general public for the utility to locate their facilities in such a manner that will avoid conflicts and eliminate the need for additional costs due to the planned project. A permit will be issued if the utility demonstrates that they can install their facilities in such a manner that will avoid conflicts with the active project.

**5.6.B.5. Identification** -

- a. **Poles** – Each pole shall bear a nameplate or label listing the following:



1. Identifiers consisting of the utility company name and utility company phone number. The identifier shall be capital letters, and shall be of a type size large enough to be legible without the aid of magnification.
  2. Any other statements or labeling requirements imposed by the rules governing the FCC operation of the specific class of equipment attached to the pole expect that such statement(s) of compliance may appear on a separate label at the option of the utility.
  3. The nameplate or label shall be permanently affixed to the pole and shall be readily visible at the time of installation. As used here, permanently attached part of the pole. Alternatively, the required information may be permanently marked on a nameplate of metal, plastic or other material fastened to the pole by welding, riveting, etc., or with a permanent adhesive.
  4. Such a nameplate must be able to last the expected lifetime of the pole in the environment in which the pole will be placed and must not be readily detachable.
  5. Where it is shown that a permanently affixed nameplate is not desirable or is not feasible an alternative method of positively identifying the pole may be used if approved by the Department. The proposed alternative method of identification and the justification for its use must be included with the permit for authorization.
- b. **Overhead communication** - Cable pole attachments shall bear a tag or label listing the following:
1. Identifiers consisting of the utility company name and utility company phone number. The identifier shall be capital letters, and shall be of a type size at least  $\frac{3}{4}$  inches tall with black letters on an orange background. The identifier shall be legible from the ground.
  2. Any other statements or labeling requirements imposed by the rules governing the FCC operation of the specific class of equipment attached to the pole, except that such statement(s) of compliance may appear on a separate label at the option of the utility.
  3. Communication cable attachments shall be marked on the following poles: every end pole, every junction pole and

every fifth pole on longitudinal installations. Multiple attachments on the same pole shall be marked.

4. Such tag or label must be able to last at least 10 years in the environment in which the attachment is made. Older tags shall be replaced as the poles are visited.

**5.6.C. Communication Cables Crossings** - The installation of heavy aerial cables (as a general rule any cable larger than 1 inch in diameter and depending on the geographical region) over divided highways shall be prohibited. These lines usually are difficult to maintain over high speed traffic. It is in the best interest of the highway user to require communication cables (telephone, T.V., etc.) crossing divided highways to be placed underground or in duct on bridges.

**5.6.D. Power Transmission Lines** - Due to the size of the structures, transmission facilities larger than 115 KV, as a rule, are not allowed for longitudinal installations on the right-of-way. However, exceptions may be granted on a case by case basis by the Director of Permits & Operations when the applicant can substantiate factually that all alternates have been studied and that no other practical alternate exists

## **5.7 INSTALLATION ON OR NEAR HIGHWAY STRUCTURES**

**5.7.A. General Considerations** - Attaching utility lines to a highway structure can materially affect the structure, the safe operation of traffic, the efficiency of maintenance, and the appearance. Where it is feasible and reasonable to locate utility lines elsewhere attachments to bridge structures are to be avoided.

On existing bridge structures, attachments of water or sewer lines are limited in size to 12 inch or smaller line only. Water or sewer lines larger than 8 inches shall not be suspended from the slab. Gas lines exceeding 300 psi pressure, in particular, will not be approved for bridge attachment. However, where other locations for a utility line to span an obstruction prove to be extremely difficult and unreasonably costly, consideration may be given for attaching the utility line to a bridge structure by a method acceptable to the Department. Such methods should conform to engineering considerations for preserving the highway and its safe operation, maintenance and appearance. In these respects, the following considerations predominate.

**5.7.B. Controls for Bridge Attachments** - Since highway structure designs and site conditions vary, the adoption of standardized methods to accommodate utility facilities on structures is not feasible. Each proposed bridge attachment will be considered on its individual merits and shall be separately designed. All design details for utility attachment to bridges shall be submitted to the State Bridge Office on copies of Department bridge plans for approval prior to the permit being approved by the District Engineer.

**5.7.B.1. Structural and Design Requirements -**

- a. Utility facilities are to be designed in accordance with all governing codes.
- b. Bridge attachment of a utility facility will not be considered unless the structure in question is of a design that is adequate to support the additional load and to accommodate the utility facility without compromise of highway features, including ease of bridge inspection and maintenance.
- c. Where a utility facility is carried beyond the back of an endwall or bridge abutment, generally it shall be required to extend beyond the approach slab and curve or angle so as to align outside the roadbed structure in as short a distance as is operationally practicable. Preferably it should be located in the first or closest bay of the structure (i.e. - not on the outside of the bridge). Where attachment is considered, coring or cutting of edge beams or approach slabs will not be allowed. On endwalls, whose primary purpose is to retain the end fill, approval may be granted to core reasonable sized holes provided critical reinforcement is not cut.
- d. Acceptable utility attachment methods are hangers and/or roller assemblies suspended either from inserts in the underside of the bridge deck or from hanger rods clamped to the flange of some superstructure member. Hanger assemblies shall not be placed on an expansion joint, or at a bearing stiffener or similar structural features.

Where attachments are allowed, chemical anchors, expansion type anchors or a combination of both may be permitted. Chemical anchors are NOT ALLOWED IN DIRECTION TENSION IN OVERHEAD APPLICATIONS. However, anchorages may be permitted in combination of additional “fail-safe” connections. Generally shear type connections are preferable. Diaphragms or cross frames will not be used to support utility facilities. However, approval may be granted to core reasonable sized holes in diaphragms provided critical

reinforcement is not cut. Coordination with the Bridge Office for attachments to bridges is required.

Utility facilities shall not be suspended from bridge slabs in areas where concrete deck panels have been used in construction. Bolting through the bridge deck, drilling into prestressed concrete beams or post tensioned portions of any concrete structure will not be permitted. No welding will be allowed on any existing structural steel on any bridge. No clamping attachments that create a stress concentration will be permitted on any structural steel structure.

- e. The utility company will be required to make satisfactory provisions for the lineal expansion and contraction of its facility due to temperature differentials. Line bends or expansion couplings are most prevalently employed for this purpose. Bridge structures shall not be used as thrust blocks for utility facilities under pressure.
- f. All material attached to or used in the bridge structure pipe or duct line attachments must be approved by the State Bridge Office. All metal components shall be galvanized or made from stainless steel.
- g. Manholes for utility access will not be allowed in the bridge deck.
- h. Utilities will not be allowed on bridges where bridge fills or abutments are retained by reinforced earth-type walls.

#### **5.7.B.2. Clearances -**

- a. Utility facilities attached to bridge structures shall maintain a vertical clearance at least equal to that of the structure at any point.
- b. Utility location on a structure which would inhibit access to any part for bridge inspection, painting or repair will not be allowed. Clearances of the utility facility from bridge members shall conform to all governing codes.
- c. Generally, acceptable utility installations are those which will occupy a position beneath the structure's floor between the outer girders or beams, or within a cell.
- d. New utility installations on an existing bridge shall be placed a minimum of 18 inches from existing utilities.

#### **5.7.B.3. Aesthetics -**

- a. Utility facilities attached to the outside of bridges are unsightly and susceptible to damage. They will not be permitted unless the Utility can show that there is no reasonable alternative.
- b. Utility facility mountings are to be of a type which will not rattle due to vibrations caused by traffic. The support rollers, saddles or hangers shall be coated or padded with neoprene or otherwise equipped to muffle vibration noise.

#### **5.7.B.4. Restoration -**

- a. When the utility facility is to pass through a bridge abutment or end wall of an existing bridge, the utility company shall neatly restore the disturbed areas by methods which will prevent any leakage of water or backfill through the substructure elements. Where such construction is proposed, the hole created in the bridge end wall or abutment to permit passage of the facility shall be of the minimum size. The annular space between end wall or abutment and pipe shall be completely filled with a suitable material of a nature to seal such opening and effectively prevent the leakage of any moisture or backfill material through the abutment. Where a pipe or conduit is to be "sleeved" through the end wall or abutment, the sleeve shall be tight-sealed into the opening and the annular space between the pipe conduit and the sleeve sealed with mastic.
- b. The Utility will be required to restore or repair any portion of bridge or highway disturbed by the installation or use.

#### **5.7.B.5. Encasement -**

- a. Since a pipeline carrying a volatile fluid or gas under pressure can cause damage or injury if there is a leak, it poses a certain element of risk when mounted on a bridge. Likewise, attachment of a pipeline carrying a non-volatile fluid, such as sewer or water, also poses a certain element of risk, with respect to leakage, where mounted on an above ground structure such as a bridge crossing a freeway, highway, street, road, railroad, or water. In either case, when such a carrier is placed in a casing pipe of leakproof construction, leakage can be detected and exhausted at vents or drains and the casing becomes a "second line of defense" against the hazard of explosion. Casing shall be required for all such pipeline attachments throughout the bridge. Exceptions to this requirement shall be approved by the State Utilities Engineer. The casing pipe shall be carried beyond the

back of the bridge abutment and approach slab, and be effectively opened or vented at each end to prevent possible build-up of pressure and to detect leakage of gases or fluids.

- b. When a casing is not provided for a pipeline attachment to a bridge, additional protective measures shall be taken. Such measures may include a higher factor of safety in design, superior design and construction, radiograph testing of welds and hydrostatic testing.
- c. Communication and electric power line attachments are to be suitably insulated, grounded and carried in protective conduit or pipe from the point of exit from the ground to re-entry. The cable shall be carried to a manhole located a minimum of 40 feet beyond the endwall of the structure. Carrier pipe and casing pipe shall be suitably insulated from electric power line attachments.
- d. Utility facilities shall be encased when they are located under bridge approach slabs. The casing shall extend from the endwall to a point beyond the approach slab.

#### **5.7.B.6. Cathodic Protection -**

- a. Utility facilities, such as gas, water, etc., which are attached to bridge structures shall be free of any impressed direct current for cathodic protection or shall be electrically isolated from the bridge.
- b. When utility lines containing impressed direct current are to be attached to a bridge structure, the following precautions shall be taken unless other suitable protection is detailed on permit plans and details
- c. Insulating flanges or connections shall be installed beyond each backwall of the bridge structure for the purpose of insulating or isolating the section of the facility attached to the bridge structure from the underground sections of the facility containing impressed direct current for cathodic protection.
- d. If necessary the direct current shall be continued across the bridge through an insulated wire attached to the underground facility at each end of the bridge. This insulated wire shall be enclosed in metallic conduit. Both this conduit and the facility or its casing shall be insulated from the bridge structure. This conduit shall be grounded to a ground rod at each end of the bridge.

#### **5.7.B.7. Shut-off Valves -** On all facility attachments carrying gas or liquid

under pressure, which, by nature of the transmittant or its pressure, might cause damage or injury if escaping on or in the vicinity of the highway structure, there shall be emergency shut-off valves. Such valves shall be placed within an effective distance each side of the structure, unless the facility is equipped with nearby shut-off valves or operates under effective control by automatic devices.

**5.7.C. Controls for Utilities Near Highway Structures** - Buried non-pressurized utility installations allowed under bridges shall be no closer than 5 feet laterally and shall be above the footings; or 10 feet laterally to piles or trestle pile bents. Buried pressurized utility installations under bridges shall be no closer than 10 feet laterally and shall be cased for a minimum distance of 25 feet from the edge of footing. Requests for placement of utilities near reinforced earth type walls may be allowed after special review by the Department. Minimum lateral clearance between a bridge and an underground utility crossing a limited access highway shall be 100 feet.

## **5.8 SPECIAL CASE UTILITIES (IRRIGATION, DRAINAGE FACILITIES, AND CLAY PIPELINES)**

Irrigation, drainage facilities and clay pipelines installed across right-of-way generally shall be designed and constructed in accordance with the Department's construction details for culverts. Ditches and canals that closely parallel the highway shall be discouraged. Appurtenances which would constitute a hazard to traffic shall not be permitted within the clear roadside areas and, preferably, should be located outside of the right-of-way.

**5.8.A. Controls for Public Right-of-Way by Private Irrigation Lines** - Due to a growing demand for crossings of the right-of-way by privately owned irrigation lines used in farming operations, or to gain access to sources of water for irrigation purposes, the following controls are require in order to protect the right-of-way and permit reasonable access to adjacent property owners accommodating these special case utility facilities.

**5.8.A.1. Highway Crossings** - Highway crossings by irrigation lines shall be permitted under similar conditions and standards as apply to underground utility lines as follows:

- a. Crossing shall be installed at right angles to the centerline of the road insofar as possible.

- b. Open cutting of pavements will not be permitted. Crossings shall be bored beneath the pavement and a permanent casing installed. Minimum cover from top of pavement to top of casing shall be 4 feet (unless 4-lane roadway, then minimum depth is 10 feet). Casings larger than 4 inches in diameter shall be required to utilize boring type construction.
- c. Lines installed as permanent installations shall be buried across the right-of-way with a minimum cover of 3 feet except for the section beneath the pavement.
- d. Temporary lines may be laid across the right-of-way on top of the ground outside the ditch lines or toe of fill. Temporary lines are those which will remain in place for no more than 2 days during each period of use.
- e. Irrigation lines shall not be installed inside cross drain pipes or culverts. Lines may cross underneath bridges, either below ground or on top of the ground in accordance with paragraphs b. and c. above. "Lines may be placed inside cattle passes or other structures designed for access across the road."
- f. Immediately upon completion of each installation the applicant shall restore the right-of-way to original condition. This shall include backfilling and compacting excavations, dressing slopes and grassing as necessary.

**5.8.A.2. Longitudinal Installations** - Irrigation lines shall not be installed parallel to the roadway along the right-of-way. Short exceptions, up to 100 feet, may be made in conjunction with a road crossing where necessary to reach a location with suitable topography to install the crossing.

**5.8.A.3. Controls** - Permits for irrigation line crossings will be administered under the Department's *Utility Accommodation Policy and Standard Manual*.

- a. The Permit General Provisions (Rules and Regulations) issued shall apply to irrigation line permits. A copy of these rules shall be attached to the applicant's copy of each approved permit so that there is no misunderstanding as to the responsibilities and liability of the applicant.
- b. A bond shall be required for each irrigation line permit. The minimum bond will be \$5,000 per lane. A larger amount may be required at the discretion of the District Utilities Engineer, depending upon the nature of the installations and the potential



damage to the roadway. The bond must be in hand before the permit is approved and shall be required to remain in effect for a period of 12 months after permit work is completed.

- c. Permit requests which are in compliance with all the above requirements may be approved by the District Engineer. Any request for exceptions to this policy shall be forwarded to the State Utilities Engineer if recommended for approval by the District Utilities Engineer.

**5.8.B. Controls for Clay Pipelines** - Due to clay pipelines are a special case "utility", being privately owned and not serving a public purpose under the usual concept of a utility, the following policy and procedure shall apply to use of State rights-of-way by these facilities.

**5.8.B.1. Highway Crossings** - Highway crossings by clay pipelines shall be permitted under similar conditions and standards as apply to underground utility lines as follows:

- a. Crossing shall be installed at right angles to the centerline of the road insofar as possible.
- b. Open cutting of pavements will not be permitted. Crossings shall be bored beneath the pavement and a permanent casing installed. Minimum cover from top of pavement to top of casing shall be 4 feet (unless 4-lane roadway, then minimum depth is 10 feet).
- c. Clay pipelines shall not be installed inside cross drain pipes or culverts. Lines may cross underneath bridges, or placed inside cattle passes, or other structures designed for access across the road.
- d. Immediately upon completion of each installation the applicant shall restore the right-of-way to original condition. This shall include backfilling and compacting excavations, dressing slopes and grassing as necessary.

**5.8.B.2. Longitudinal Installations** - Clay pipelines shall not be installed parallel to the roadway along the right-of-way. Short exceptions, up to 100 feet, may be made in conjunction with a road crossing where necessary to reach a location with suitable topography to install the crossing.

- 5.8.B.3. Controls** - Permits for clay pipeline crossings will be administered under the Department's *Utility Accommodation Policy and Standard Manual*.
- a. The Permit General Provisions (Rules and Regulations) shall apply to clay pipeline permits. A copy of these rules shall be attached to the applicant's copy of each approved permit so that there is no misunderstanding as to the responsibilities and liability of the applicant.
  - b. All applications for new installations should be reviewed at the District Utilities Office, including a field investigation. Permit requests which are recommended for approval shall be forwarded to the State Utilities Engineer, if recommended for approval by the District Utilities Engineer, for further handling and approval.
  - c. A bond will be required for all clay pipeline installations. The amount of the bond will be set by the District Utilities Engineer, taking into consideration the nature of the installation and the potential for damage to the roadway during construction and in event of a pipeline failure. The initial bond shall be executed and attached to the permit application before it will be approved.
  - d. Bonds shall be renewable annually for as long as the pipeline remains within the right-of-way. Upon each annual review the District Engineer may change the required amount of the bond at his discretion.

## **5.9 PUBLIC TELEPHONES**

### **5.9.A. General Requirements and Controls -**

1. No telephone booth shall be located in such a manner to that interferes with site distance.
2. No telephone booth shall be located at a site which does not permit safe and satisfactory connections between the highway travel lanes and the driveway serving the telephone booths. The existence of accel and decel lanes, proximity to an intersection or drainage structure or any other existing condition which may result in a hazard or an inconvenience to traffic shall be considered.
3. No telephone booth shall be installed at a location which requires or encourages parking on the highway travel lane or within a 10 foot area.

The telephone booth will generally be located adjacent to a driveway or parking area.

4. Telephone booths may be so located that existing parking areas off the highway right-of-way may be used by patrons of the telephone. In such instances the permit application must be endorsed by the owner or lessee of the parking area which will be used by the telephone patrons.
5. No permit shall be issued for a telephone within the right-of-way fronting a business whose driveway plan does not conform to the Department's requirements for commercial driveways as provided for in the *GDOT Driveway and Encroachment Control Manual*, as verified by the District Traffic Engineer. Telephones booths shall not be located where they will encourage parking in driveway areas.
6. No permit shall be issued for a telephone installation to a utility without prior certification of the Georgia Public Service Commission (PSC) for Payphone Service Providers (PSP).
7. The utility shall insure that the telephone booth complies with handicapped access in accordance with the American Disabilities Act (ADA).

### **5.9.B. Interstate and Limited Access Highways -**

1. Telephones will be permitted only within areas removed from the roadway and to which adequate speed-change lanes and connections are provided. This will include safety rest areas, truck-weight stations and information sites. This restriction will not apply to motorist-aid stations which may be installed to assist drivers in emergency situations. Such telephones will be installed by special agreement with the Department and will not require a separate permit.
2. Where a public telephone exists in the vicinity of an interchange, the sign located on the Interstate Highway right-of-way to indicate motorist service facilities, if used, shall include the message "PHONE".

**5.9.C. Highways in Rural Areas** - In rural areas where a normal roadside ditch exists, that part of the telephone driveway used for parking of vehicles while occupant uses the telephone shall be on the opposite side of the side ditch from the travel lane of the highway. Where no roadside ditch exists, the near edge of the telephone driveway shall be a minimum of 15 feet from the edge of the highway travel lane. There shall be an island at the location opposite the telephone booth. The island shall be a minimum 10 feet long and protected by a 6 inch curb. The line of the island nearest the travel lane shall be as specified

in the Department's requirements for commercial driveways. The line of the island furthest from the travel lane shall be at the edge of the telephone driveway and as approved by the District Traffic Engineer. The type of pavement and method of construction of driveways providing access to the telephone, as well as the maintenance of these driveways, shall be the responsibility of the Applicant. Where drainage culverts are required, the District Engineer shall specify the size to be installed.

**5.9.D. Urban Streets** - In urban areas, telephone booths may be installed within the right-of-way where approved existing parking facilities are available near the desired site. If the street is curbed and designed for curbed parking, telephones may be located at an available site not interfering with vehicles or pedestrian traffic. Locations within a municipality shall have the concurrence of the appropriate official of the municipality.

**5.9.E. Signs** -

1. All signs pertaining to telephone service located within the right-of-way of State Highways other than highways on the Interstate System shall be furnished, erected and maintained by the telephone company.
2. A maximum of two signs located within the right-of-way in each direction from the telephone site indicating the distance thereto shall be permitted. An arrow sign shall be permitted on each side of the roadway at the telephone station or a double faced sign on one side only. Plans for signing shall be included with the permit application.
3. All signs shall conform to the *Manual on Uniform Traffic Control Devices* (MUTCD), current edition as to dimensions, color, message, etc., and to the Department's Standard Specifications current edition, as to fabrication and materials.

## **5.10 LIGHTING PROCEDURES – LIGHTING BY PERMIT**

This section of the UAM will address utility permits for which the lighting is on State Right-of-Way and the request is initiated by a Local Government or a private Applicant/Developer (Applicant). The Department has adopted the American Association of State Highway and Transportation Officials (AASHTO) policy Roadway Lighting Design Guide (current edition) for the State of Georgia. The Department also publishes the GDOT Design Policy Manual; refer to Chapter 5 for information regarding roadside safety and lateral offsets to obstructions and Chapter 14 for lighting requirements. The materials presented in those chapters establish uniform procedures and standards for roadway lighting system design and apply to permitted

Utility lighting installations. With the adoption of this Manual, existing lighting systems are not intended to be modified as a result of the policies outlined in this chapter.

**5.10.A. General Requirements and Controls** - When the Department is not assisting in the funding of the lighting to be installed, a utility permit will be required. The Local Government or Applicant will be responsible for one-hundred percent (100%) of all associated costs, the energy, operation, and maintenance of the lights/lighting system, and for meeting all State requirements for lighting design. The Department will review, approve, and issue the permit documents; the Local Government or Applicant will retain ownership of the system.

All utility permit applications to place lighting facilities within GDOT Right-of-Way will be submitted via GUPS as Electrical permits to begin the review process.

- The District Utilities Office (DUO) will assign the permit to the Roadway Lighting Group (RLG) and the State Utilities Office (SUO) for review and comment
- The DUO will review the electrical permit and light pole locations for compliance with the UAM and AASHTO clear zone guidelines
- The RLG will review the light pole/light standard locations, electrical hookups, height of lights and position to ensure the lighting installations are in accordance with recommended practice, design policy and best practices, and will approve the photometrics for new permits and conversions (HPS to LED)
  - If the photometric design file is an AGI32 or similar, the Utility Owner will separately submit it to the RLG via email
  - Photometrics must be approved by the RLG before a permit is released
  - Conversions will require the simultaneous submission of existing and proposed photometrics
  - Adding to an existing lighting system is considered a new installation and subject to review
    - On the permit drawings, the existing section will need to be labeled and will not be required to be updated to current standards
    - The RLG will determine how the new fixtures interact within the overall system

- Any lighting installation, including a single light pole/light standard, along or involving a State Route or greater is subject to approval
- The DUO will upload RLG's approval into GUPS
- The SUO will develop a Memorandum of Agreement (MOA) (Lighting Agreement) or a Special Provision for Lighting
  - MOAs will be signed by the Local Government and GDOT Management and uploaded into the GUPS permit
    - MOAs must be fully executed before the permit is released
  - The SUO will send an electronic copy of the fully executed MOA to the RLG
  - The DUO will return an original, fully executed MOA to the Local Government
- In special cases where there is no Local Government MOA, the SUO will provide a "Special Provision for Lighting" to be uploaded into the GUPS permit

After all concurrences have been received and a fully executed MOA or the Special Provision for Lighting has been uploaded into the permit, and the RLG approval has been uploaded into GUPS, the permit can be released for installation.

**5.10.B. Information to Accompany Permit** - In addition to the items required to be shown on a standard utility permit per Section 3.6.A of this Manual and items mentioned in Section 5.10A. above, all documents, calculations and files required in Chapter 14 of the GDOT Design Policy Manual, and a completed "Checklist for Lighting Permits", available on the Utilities Permitting webpage, shall be included with the permit application.

**5.10.C. Light Pole/Light Standard Locations** - Light poles/light standards shall be located with consideration being given to traffic flow and a roadside recovery area and to be minimally obstructive for Department maintenance operations. Median lighting is only acceptable if integrated with concrete median barrier installations and/or existing barrier.

The AASHTO *Roadside Design Guide's* (current edition) provides clear zone guidelines and Chapter 5 of the *GDOT Design Policy Manual* provides guidance for minimum lateral offsets to obstructions. Additionally, each permit will be reviewed to prevent new light poles/light standards from being installed in the shaded control zones (see Section 5.6.B, Figures 7 to 13 of this Manual) to the extent as possible.

**5.10.C.1. Non-Breakaway Light Poles/Light Standards** - Pole/light standards without breakaway features are acceptable only when located beyond the distance required by the clear zone guidelines. Pole/light standards may be located behind existing guardrail if protected from all directions of travel. If located behind guardrail, pole/light standards shall be offset sufficiently to allow for deflection of the guardrail under impact.

When determining the required clear zone distance, first check whether a clear zone has been previously established for the route from the District Utilities Office. If a clear zone has not already been established then posted speed and the roadside geometry is the determining factor.

**5.10.C.2. Breakaway Light Poles/Light Standards** - Any light poles/light standards that are not located outside of the clear zone shall be mounted on an AASHTO compliant breakaway bases (or breakaway couplings) with breakaway wiring connectors, unless shielded by a barrier. The Local Government or Applicant shall consider the size of the base when measuring horizontal clearance since breakaway or frangible bases are generally wider than the pole/light standard.

**5.10.D. Wire Requirements** - Where breakaway bases are required, overhead wiring will not be permitted. In cases where wood light poles or light standards without the breakaway feature are permissible, overhead wiring will be allowed. Where overhead wiring is allowed, only normal conductor crossings will be allowed to complete circuit wiring; conductor crossings will not be permitted from pole to pole on a staggered pole arrangement. Refer to Chapter 14 of the *GDOT Design Policy Manual* for other requirements.

**5.10.E. Removal of Lighting Facilities** - This section applies to light poles/light standards for which the sole function is to support lighting facilities and for which the original right of occupancy was derived by permit from the Department. When any lighting installation or system ceases to be maintained or operated for a period of 60 consecutive calendar days, the District Utilities Office shall give written notice to the owner of the light(s)/lighting system that they have 15 consecutive calendar days from the date of the written notice to begin maintenance or restore the lighting. If work has not begun within this time, then:

- The lighting will be considered a hazard and subject to removal by State forces
- All materials and equipment removed shall become the property of the Department for disposal or other use, as deemed appropriate. Any cost to the Department to remove said facilities shall be reimbursable by the Local Government or Applicant as per Section 2.8.D.3 of this Manual

### **5.11 WIRELESS FACILITIES**

**5.11.A. Guidelines** - The following policies and procedures are for accommodating and controlling access of wireless telecommunications facilities, small or micro cell facilities, Wireless Support Structures on the highway right-of-way and other non-highway real property owned by Department. This section is not intended to hinder a utility's ability to operate their own wireless facilities (e.g. sectionalizing devices, reclosers, breakers, etc.) with communications to line devices but to ensure devices and supporting structures are consistent with Department Policy and Procedures. Unless noted in the following subsections, standards contained in UAM 5.6 Overhead Power and Communications are applicable.

Prior to commencing any work on the highway right of way and/or State-owned property, the applicant shall have applied for and obtained an approved permit from the Department, for the applicable county and route. In addition to the wireless facility, the permit will allow applicant the right to construct and maintain a public service utility line for a maximum distance of fifty-two feet (52') within the limits of a highway right of way and State-owned property. Each permit shall be in accordance with the Utilities Accommodation Policy and Standards Manual ("UAM"), current edition. Applicant shall apply for permits using the Department's standard electronic permitting format known as GUPS (Georgia Utilities Permitting System).

**5.11.B. Controls for Wireless Facility Installation** – Collocation of antennas on existing infrastructure within the right of way is required. Exceptions may be granted by the State Utilities Engineer. Exceptions may be considered on a case by case basis when the utility company can show the impracticality of all other alternatives. Exception requests shall be in writing and shall include technical and physical constraints plus any other supporting documentation substantiating the need.



Substantial modifications to existing Wireless Support Structures will require new permits. A substantial modification is a 10% or greater increase in height of a Wireless Support Structure or the installation of an additional antenna.

**5.11.B.1. Collocation on Non- Department Infrastructure** - The Department shall permit applicant to collocate antennas and other associated equipment on existing poles, not owned by the Department within the Department's right-of-way. The utility owner/wireless service provider shall obtain all necessary approvals from the pole owner prior to placing any antennas, wires, cables, equipment, etc. on any pole. The wireless facility owner shall also satisfy all NESC, NEC, OSHA and other applicable Federal and State codes. When required, adjustments to the existing support structure or utility is required, the pole owner is required to obtain a separate permit for the installation of or adjustment to the existing utility infrastructure.

**5.11.B.2. Collocation on Department Infrastructure** - Available GDOT infrastructure is limited to traffic signal strain poles, concrete or metal sign strain poles, and mast arms. The Department may permit applicant to place antennas and other associated equipment on existing signal and strain poles, owned by the Department, within the Department's right-of-way. Proposed attachments must be reviewed by the District Traffic Operations Office. Installations shall not compromise, hinder nor effect the operations of the traffic signal or associated equipment. If modifications are required to a strain pole, mast arm or joint-use facility, the cost of the adjustment shall be borne by the wireless service provider.

**5.11.B.3. Wireless Support Structures** - Wireless Support Structures shall be designed to accommodate multiple antennas, positioned in a manner that is not obstructive to normal maintenance and operations within the right-of-way, and shall not be located in a manner that violates ADA requirements. All cabling and power connections shall be internal to the structure. Cabinets and auxiliary equipment shall be mounted on the structure.

Where permitted, Wireless Support Structures shall not have a height (measured from the ground) exceeding the greater of 50 feet or 10 feet above the height of similar utility poles located within 500 feet of the proposed installation. Where no utility

poles exist, a new wireless support structure shall not exceed 65 feet in height measured from the ground.

New Wireless Support Structure installations shall be spaced according to the following minimum distances from adjacent Wireless Support Structures:

**Urban/Suburban Areas** - 500' radially

**Rural Areas** - 750' radially

Each proposed structure will be reviewed to restrict facility installations within “shaded zones” as depicted in figures 7 to 13 (see Section 5.6.B) of this Manual. The AASHTO *Roadside Design Guide* (current edition) clear zone guidelines are to be used to determine the desired distance for Wireless Support Structures in addition to desirable set-back distances noted as follows:

**Rural:** Unless greater distances are required, the desirable distance shall be 30 feet from the edge of pavement. When the Utility can demonstrate that these set back distances are not practical and crash data supports a safe roadside environment, the *Roadside Design Guide*, current edition, will be used as a basis for determining exceptions.

**Urban:** In keeping with the nature and extent of roadside development along roadways in urban areas, such facilities shall be located as near as possible to the right-of-way line and outside the clear zone. Where there are curbed sections, the utilities are to be located as far as practical behind the face of curb. See below for the minimum lateral clearances and the respective posted speed limits:

<u>Lateral Clearance (min.)</u>	<u>Posted Speed Limit (mph)</u>
12'	45 greater
8'	$35 \leq x < 45$
6'	< 35

**Aesthetics:** Wireless Support Structures and antennas shall be context sensitive and satisfy applicable

ordinances for stealth installation requirements, color, or other approved designs. The local governing authority shall have the ability to petition the Department for relief from proposed installations that are not in accordance with a local ordinance, zoning code or other statute related to aesthetics. The local governing authority shall also have an opportunity to request that proposed installations be completed in a manner that is context sensitive including but not limited to undergrounding, historic, cultural, or central business district requirements. Composite, hollow, non-conductive poles should be utilized for standalone Wireless Support Structures.

- 5.11.C. Permits** - Applicant will apply for a permit for each separate location (County and route) for which applicant desires to locate its equipment and abide by the terms of that permit.

The permit shall include, but not be limited to, items in Section 3.6.A., individual site plan designs for each location showing the proposed pole and attachments, utility services required, Antenna and/or structure height, and all details including a vicinity map. The placement of the wireless facility may require a letter from electric utility facility or other pole owner adjacent to the installation site to verify NESC requirements are met.

**This Page Intentionally Left Blank**

## **CHAPTER 6: VEGETATION MANAGEMENT**

### **6.0 GENERAL CONSIDERATIONS**

All Utilities must submit an annual Vegetation Management Schedule for each of the Department's Districts, utilizing GUPS, to perform any vegetative maintenance activities on any PERMITTED Utility Facility that encroaches the State Highway System; *or the Utility must submit individual site plans for the planned maintenance activities each year, in conformance with the General Requirements of this policy.*

Vegetation Maintenance Activities include mowing, chemical control, and pruning and tree removal.

Utilities requesting NEW Utility Facility Encroachment Permits may be required to include a Mitigation (Landscape) Plan with their Encroachment Permit Application for facility crossings on Interstate and Limited Access Highways. (See Section 6.2 of this Manual.)

### **6.1 ANNUAL SCHEDULE FOR VEGETATION MANAGEMENT**

**6.1.A. Submittal Requirements and Procedures** - Submit one Vegetation Management Schedule for each maintenance activity, annually, for all of the existing and new right-of-way encroachment sites in each of the Department's Districts. See the current "District Boundary Map for Vegetation Management" on GDOT's Utilities webpages.

The Utility can choose to submit one schedule for all three maintenance activities or submit up to three separate schedules. This will depend on the Utility's Maintenance Plan. If a Utility only has facilities within one District, only one schedule has to be submitted. The Vegetation Management Schedule may be requested from and shall be submitted to the District Utilities Engineer's Office via GUPS. The District Utilities Engineer shall review the schedule and forward it to their designated personnel responsible for utility encroachments. Upon receiving an approved schedule, including any conditions stated therein from the Department, the Utility should have a 1 year schedule to perform approved maintenance activities.

**6.1.B. Alternative Compliance** - Should the Utility choose not to submit a Districtwide Vegetation Management Schedule in conformance with policy requirements, then the Utility should submit to the District Utilities Engineer

an alternative compliance request and site plan for each encroachment site in the District. The District Utilities Engineer shall review the request for approval. The request shall state policy(s) for which alternative compliance is sought, hardship, and proposed alternative maintenance activities. Each site plan shall contain the following: A plan at 1"=20'-0" scale showing the utility area, State Route, mile post, right-of-way line; the existing vegetation in and adjacent to the site; and a maintenance schedule on the plan indicating the specific activities that are to occur. The maintenance schedule shall indicate, but may not be limited to, specific activities that are to occur, such as which trees are to be pruned, what chemicals are to be used, how cut material will be disposed of, how often mowing shall occur, and what control procedures shall be used for exotic species.

- 6.1.C. Emergency** - In the event of an emergency, the Utility will establish communication with the Department to report the location(s) of possible damaged areas, degree of damage, and other available information. Communication should be established as soon as practical but no later than 2 hours after the onset of the emergency.

## **6.2 NEW UTILITY FACILITY ENCROACHMENT PERMITS ON INTERSTATE/LIMITED ACCESS HIGHWAY**

The Department may require landscape mitigation for "New" Utility Facility Encroachment Permits, on Interstate/Limited Access Highways, to reduce the impact of the vegetation removal.

If required by the Department, the Utility shall submit, for review and approval, a Landscape Mitigation Plan with each new Utility Facility Encroachment Permit application that involves Interstate/Limited Access Highways. The Landscape Mitigation Plan shall be in addition to the Site Plan provided with the permit application. The Mitigation Plan shall conform to the Maintenance Requirements (see Section 6.4) and the General Mitigation Plan Requirements (see Section 6.2.C) of this Manual, and the Department's Standard Specifications, current edition, Section 702 - Vine, Shrub and Tree Planting and Maintenance. Mitigation installation shall be completed within 12 months of any vegetation management activity.

- 6.2.A. Mitigation Plan for Utility Crossings** - A minimum of 45% of the disturbed vegetation management zone shall be planted with native shrubs. The shrubs shall be planted in natural groupings, not long rows. Shrubs shall be spaced in order to achieve 100% coverage within the natural grouping in

two growing seasons. Spacing guidelines for determining shrub quantities for a given area are:

Spacing S.F. (S.F. = square foot coverage)

12"	1.00
18"	2.25
24"	4.00
36"	9.00
48"	16.00
60"	25.00
72"	36.00
84"	49.00
96"	64.00

[For example: If 45% of the required landscape area (4,500 s.f.) is 2,025 s.f., and you request to plant wax myrtles at a 96" spacing; then, 2,025 s.f. divided by 64 s.f. equals 32 wax myrtles that are required to be planted.]

All areas of the disturbed vegetation management zone that are not planted with native shrubs shall be grassed. Mowable areas (slopes 3:1 or less) shall be planted with a permanent turf grass, as per the Department’s Standard Specifications, current edition, Section 700 - Grassing. Non-mowable areas (slopes greater than 3:1) shall be planted in accordance with the Department’s Standard Specifications, current edition, Section 700 – Grassing, and Section 161 – Control of Soil Erosion and Sedimentation.

**6.2.B. Mitigation Plan for Parallel Utility** - The Utility may perform vegetation removal operations up to a 20 foot width on the right-of-way. If circumstances warrant, the District Utilities Engineer may require greater than 20 feet.

Native grasses shall be seeded within the 20 foot vegetation management zone if buffered by existing groups of vegetation on the right-of-way and if slopes are unmowable. Turf Grass, as per the Department’s Standard Specifications, current edition, Section 700 – Grassing, shall be planted when no vegetation buffer exists and slopes are mowable. (See Figure 6-2a at the end of this chapter.)

When a vegetation buffer that averages less than 15 feet in width remains on the right-of-way, adjacent to a cleared vegetation management area, the District Utilities Engineer may instruct the Utility to remove the remaining vegetation, and grass as per standard specifications, at no cost to the Department.

**6.2.C. General Mitigation Plan Requirements** - The Mitigation Plan, if required, should be included when applying for the Permit Application in the GUPS. The items that shall be required in any Mitigation Plan are as follows:

**6.2.C.1. Required Plants** - The scientific name, common name, size, quantity and location of the proposed plant material.

**6.2.C.2. Schedule** - A maintenance schedule that includes the erosion control measures to be taken, the beginning planting date and completion date, the proposed chemicals to be used, and the establishment activities for a period of two growing seasons from the date of planting.

**6.2.C.3. Replacement** - After the first growing season, the Utility shall replace any mitigation materials that are not in a healthy acceptable condition or did not survive. The replacement materials should be of like size and variety as specified on the Mitigation Plan, or other NATIVE material acceptable to the District Enhancement Coordinator or designee.

**6.2.C.4. Quality** - All vegetation management activities on the right-of-way shall include the use of regionally native plants and minimize runoff. General requirements are:

- a. All plants installed shall be healthy and conform to the *American Standard for Nursery Stock*, current edition.
- b. All shrubs, perennials and vines shall be a minimum of 3 gallon material.
- c. All plant material shall be guaranteed for one growing seasons at installation and an additional one-year guarantee on replacement plants. Vegetation planted for mitigation requirements cannot be subsequently removed and must be in a healthy acceptable condition to be accepted.

**6.2.C.5. Seasonal Limitations** - Vegetation planting activities shall conform to standards established in Section 702 of the Department's Standard Specifications, current edition. For Zones 1 and 2, vegetation planting shall only be done between the dates of October 15 and March 15. For Zones 3 and 4, vegetation planting shall be done between November 1 and March 1.



### **6.3 NEW UTILITY FACILITY ENCROACHMENT PERMITS ON NON-INTERSTATE/NON-LIMITED ACCESS ROUTES**

This section applies to utility crossings and parallel encroachments on all other routes that are not included in Section 6.2 of this Manual. No mitigation plan shall be required. However, any disturbed areas shall be grassed according to Section 6.2.A.4 of this Manual for utility crossings and Section 6.2.B of this Manual for parallel encroachments.

### **6.4 MAINTENANCE REQUIREMENTS FOR EXISTING FACILITIES**

This section references existing utility facilities only. If an existing utility facility is rebuilt, updated, or reconductored, or if additional facilities are added that would require the widening of the vegetation area by additional tree removal or tree trimming, the entire utility facilities Mitigation Plan shall be reviewed as per Section 6.2 or 6.3 of this Manual.

- 6.4.A. Notification** - Give the District Utilities Engineer, or designee, a minimum of 48 hours notification prior to any scheduled vegetation management activity on the right-of-way. Provide a minimum of 5 working days notification of any changes to the approved Annual Permit.
  
- 6.4.B. Seasonal Limitations** - Permanent grassing, tree removal, tree pruning, chemical mowing and chemical activities may be performed in accordance with this policy, at any time, upon approval from the Department.
  
- 6.4.C. Pesticides** - Chemical control shall meet all State and Federal regulations. Chemical control, (i.e., spraying) may be used on vegetation 48 inches, or less, in height or any height if mowed in the previous 12 months. Chemical maintenance programs shall be supervised by a commercial certified pesticide applicator. All chemical applications shall be used in accordance with State and Federal rules and regulations. Application rate shall not exceed the manufacturer's recommendations. All spraying will be done in accordance to State and Federal Regulations (i.e. do not violate maximum wind speed). All applicators shall wear proper safety attire as recommended by the chemical instructions. Broadcast spraying is limited to areas approved by the Annual Permit. Aerial applications are prohibited. The Utility shall repair any damage that is a result of mishandling or misuse of materials at the Utility's expense and to the satisfaction of the Department.

**6.4.D. Pruning and Removal** - All pruning and removal activities shall be performed under the supervision of an ISA Certified Arborist. Local Governments are exempt from this requirement if the Local Government's employees perform the work. All trimming and pruning activities shall be in accordance with the most current ISA tree trimming and pruning guidelines:

1. The Utility shall have the right to cut, remove, and dispose of dead, diseased, weak, or leaning trees (hereinafter referred to as "danger trees") on lands of the Department adjacent to the corridor covered by the permit which may now or hereafter strike, injure, endanger, or interfere with the maintenance and operation of any of the facilities located on the corridor, provided that on future cutting of such danger trees, the applicant shall dispose of or remove the debris created thereby.
2. Crown reduction of pine trees is limited to lateral limbs. Cutting the leader of mature wood constitutes topping and is prohibited. Pruning which removes more than 1/3 of the canopy of a tree and/or leaves the tree with unnatural symmetry is prohibited. (If this type of activity is contemplated, removal should be considered, see Figure 6-2b at the end of this chapter).
3. Within the right-of-way mowable areas, tree stumps, brush stumps, root ball and roots projecting through or appearing on the surface of the ground, shall be removed by stump grinding and/or cutting flush with the surrounding ground surface. Blasting or pushing the stumps out with bulldozers shall not be permitted. In non-mowable areas (slopes greater than 3:1) remove all tree stumps, brush stumps, root ball and roots to a height of 3 inches or less above the surrounding ground. Stump height shall be measured from the top of the stump to base of stump on the lowest side of the slope.
4. All work shall be done without damage to native trees and shrubs that are to remain in the vegetation management zone or are adjacent to the vegetation management zone. All work shall be done without damage to existing site conditions. No work shall occur on right-of-way sites designated as ENVIRONMENTAL SENSITIVE AREAS (ESA) until the necessary Army Corp of Engineers permit(s) are acquired by the Utility. Contact the District Utilities Engineer to obtain the ESA locations within the District.

**6.4.E. Mechanical Mowing** - The Department will mow all utility right-of-way encroachment areas that are in an acceptable condition, have a solid stand of turf grass, as per the Department's Standard Specifications, current edition, Section 700 - Grassing, are mowable areas, and are contiguous to existing right-of-way turf grass. Mowable areas are slopes of 3:1 or less. The Utility will maintain encroachment areas containing vegetation, other than turf grass,

and/or having slopes greater than 3:1 that are within the Utility's easement (areas that the Department cannot mow). Native grasses and/or natural vegetation less than 48 inches in height may be mowed.

- 6.4.F. Erosion Control** - The Utility is responsible for slope and swale maintenance of right-of-way areas affected by the Utility's vegetation work. The Utility will adhere to all Department, State and Federal erosion control requirements at all times. If the Environmental Protection Division (EPD) or their representative requires a plan submittal from the Utility for land disturbance within the right-of-way, then a copy of the said plans shall be submitted to the District Utilities Engineer.
- 6.4.G. Debris Removal** - Properly dispose of all waste and debris and leave the site in an acceptable condition on a daily basis. When completed, the work site must be clean of all litter and debris created by the Utility and, if a mowable area, acceptable for mowing by conventional mowing equipment. Cut trees and vegetation must be removed from the site or mulched and spread evenly on the site. Mulched material spread on site shall not exceed a 3 inch maximum depth and no mulch shall be placed in an area that is susceptible to be washed into streams, drainage structures or onto adjacent properties. Mulched material shall not be spread on grassed areas. Natural debris shall not be discarded onto adjacent property without permission of the landowner.
- 6.4.H. Unsatisfactory Work** - Unsatisfactory work shall be promptly corrected by the Utility within 15 working days after notification by the Department. Unsatisfactory work deemed a safety hazard or causing erosion shall be halted and corrected immediately (within 8 hours) to the satisfaction of the Department. If necessary, the Department will correct unsatisfactory restoration work, and its cost reimbursed by the Utility prior to any future vegetation management schedules being approved or any new utility facility encroachment permits being issued by the Department.

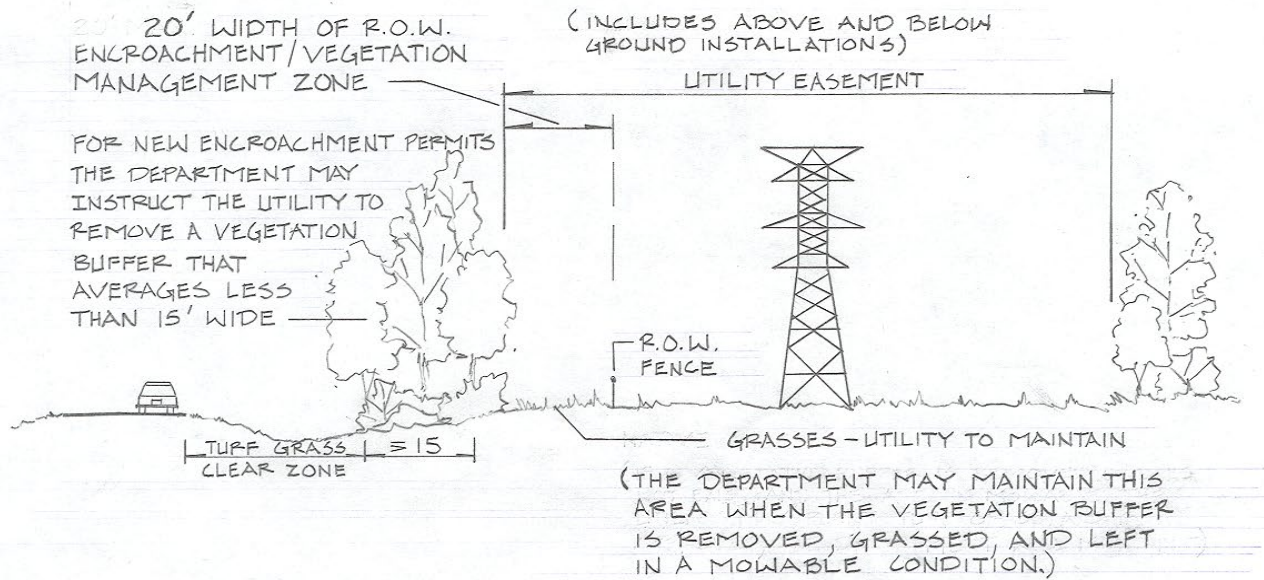

PARALLEL UTILITY SECTION

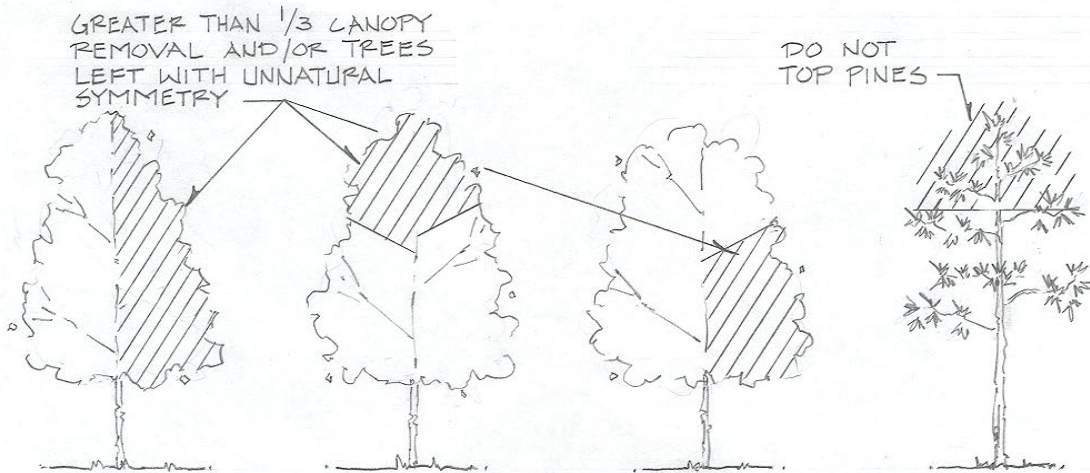

EXAMPLES OF CANOPY PRUNING ON R.O.W. TREES THAT CONSTITUTE TREE REMOVAL

**FIGURES 6-2a & 6-2b**

## **CHAPTER 7: ACCOMMODATION OF UTILITIES ON DEPARTMENT OWNED RAILROAD RIGHT-OF-WAY**

### **7.0 GENERAL**

The Department has the responsibility for reasonable regulation of Utilities on active and inactive rail corridors. When existing or proposed utility facilities occupy Railroad right-of-way, the Utility shall comply with the Department's policies and standards for permits (see Chapter 3 of this Manual) and the additional policies and standards referenced in this chapter and in the Utility Permit Special Provision for Protection of Railway Interests (see GDOT's Utilities webpages).

### **7.1 TYPE OF PERMITS REQUIRED**

- 7.1.A. General Encroachment Permit** - The Utility shall use the Georgia Utilities Permitting System (GUPS) when applying for encroachment on Railroad right-of-way.
- 7.1.B. Blasting Permit** - An approval letter from the Railroad will be required in the general permit application when the Utility's proposed work involves the use of explosives. The Utility shall obtain advance approval from the Railroad for use of explosives on Railroad right-of-way. If the Railroad does not have expertise in this area, a consultant may be required to review the blasting requirements at the Utility's expense.

### **7.2 ACCESS CONTROL**

In general, Department owned Railroad right-of-way shall be considered controlled access. Where practical, access to right-of-way should ingress and egress at public road crossings.

### **7.3 AERIAL FACILITIES**

Utility facilities installed aerially across right-of-way shall have a minimum vertical clearance of 25 feet above the rail elevation; preferably adjacent to intersecting roadways and as close to a 90 degree angle as possible. The Utility shall design the facility in such a manner to span the entire right-of-way and shall utilize joint-use practices whenever applicable.

### **7.4 UNDERGROUND FACILITIES**

When practical, utility facilities should cross underneath the tracks at a 90 degree angle. The minimum clearance shall be six (6) feet below the toe of slope of the rail bed or a minimum 3 feet below the ditch line, whichever is greater; facilities shall be encased in steel casing from right-of-way to right-of-way (i.e. water, gas & sewer). Telecommunication facilities, that are deemed non-pressurized, may be installed in a HDPE conduit at a minimum depth of 10 feet under the rail bed. Bore Pits, at a minimum, shall be 30 feet from center of tracks.

**Note:** Any other information not outlined above will be covered by the policies described in the other chapters in this Manual.

### **7.5 PARALLEL (I.E. LONGITUDINAL) INSTALLATIONS**

It is anticipated that Department owned Railroad right-of-way will have the following characteristics as Limited Access or Interstate right-of-way: Longitudinal installation of utilities will not be permitted along Railroad right-of-way. The Commissioner must approve any exceptions to this rule. Where exceptions are requested, there must be a showing by the Utility that denial of a permit would cause extreme hardship. Such requests for exception will be considered only for trunkline transmission facilities without service connections or laterals that would extend across access control lines and may require an agreement between the Department, Railroad, and Permittee.

### **7.6 TRAFFIC CONTROL**

As a minimum, traffic control shall conform to the *Manual on Uniform Traffic Control Devices* (MUTCD), current edition, for roadway locations. See Section 7.7 of this Manual for flagging requirements for Railroads.

## **7.7 FLAGGING**

**7.7.A. Flagging Services** - The Railroad has sole authority to determine the need for flagging services required to protect its operations and Department's facilities. In general, the requirements for flagging will be whenever the Utility's personnel or equipment are, or are likely to be, working on the Department owned Railroad right-of-way, or within distances as may be specified by Railroad's Representative, or across, over, adjacent to, or under a track, or when such work has disturbed or is likely to disturb a railroad structure or the railroad roadbed or surface and alignment of any track to such extent that the movement of trains must be controlled by flagging. These requirements include situations where a crane, or other piece of equipment, is located such that its boom, or extremity, could move and pass within 15 feet of the centerline of a track or within a distance as may otherwise be specified by Railroad Representative. **Normally the Railroad will assign one flagman to a project, but in some cases, more than one may be necessary.**

**7.7.B. Cost of Flagging** - The Utility shall be responsible for paying the Railroad directly for any and all costs of flagging services, which may be required to accomplish the construction. The Utility shall not delegate this responsibility to any of its contractors, subcontractors or any other party. An estimated cost of flagging service will be provided in the special provision, which is attached to the approved permit.

**7.7.C. Restrictions against Interference of Railroad Operations** - The Utility shall so arrange and conduct the work such that there will be no interference with Railroad operations, including train, signal, and communication services, or damage to the facilities or tenants on the Department owned Railroad right-of-way. Whenever work is liable to affect such operations, safety, facilities, or property, the method of doing such work shall first be submitted to the Railroad Representative for review and approval, but such approval shall not relieve the Utility from liability. Any work to be performed by the Utility, which requires flagging and inspection by the Railroad shall be deferred by the Utility until the flagging and inspection required by the Railroad is available at the job site.

Whenever work within Department owned Railroad right-of-way is of such a nature that Railroad operations are impeded to a point where the necessity for reduced speed is unavoidable, the Utility shall schedule and conduct its operations so that such impediment is reduced to the absolute minimum.

Should conditions, arising from or in connection with the work, that require that immediate and unusual provisions be made to protect operations, facilities, and property of the Department and of the Railroad, the Utility shall make such provisions. If in the judgment of the Railroad Representative, or in his absence, the Department's Inspector/Area Engineer, such provision is insufficient, either may require or make revised or additional provisions, as he deems necessary. In any event, such revised or additional provisions shall be at the Utility's expense and without cost to the Railroad or the Department.

## **7.8 SAFETY**

**7.8.A. Safety Guidelines** - The Utility shall agree and follow the safety guidelines as given in the Utility Permit Special Provision for Protection of Railway Interests (see GDOT's Utilities webpages).

**7.8.B. Federal Railroad Administration (FRA) Worker Safety** - Additional regulations may apply to Utility workers as per 49 CFR part 214 (Railroad Workplace Safety) while working adjacent to railroad tracks. This code gives certain safety regulations which workers must abide by while working on or adjacent to the tracks. The purpose of part 214 is to prevent accidents and prescribes minimum Federal standards for the railroad workplace but does not restrict the Railroad from adopting and enforcing more stringent requirements. These requirements while working on or adjacent to the tracks may vary from Railroad to Railroad and must be addressed by the Utility company with the operating Railroad prior to any work being performed by the Utility company.

## **7.9 INSURANCE AND BONDING**

**7.9.A. Requirement for Insurance** - The Utility will be required to carry self-insurance in the amount of \$2,000,000.00 per occurrence and \$6,000,000.00 aggregate as per this section, or self-insurance plus excess limits from additional companies to cover losses in excess of self-insurance limits to \$2,000,000.00 per occurrence and \$6,000,000.00 aggregate. If the Utility is not self-insured, the Utility will be required to carry insurance of the following kinds:



1. Public Liability and Property Damage Liability Insurance - The Utility shall furnish the certificate of insurance to the Railroad in TRIPLICATE and copy to the Department as evidence with respect to the operations it performs and that it carries regular Contractor’s Public Liability Insurance and regular Contractor’s Property Damage Liability Insurance both providing for limits of not less than \$2,000,000.00.
2. Protective Public Liability and Property Damage Liability Insurance - The Utility shall furnish the certificate of insurance to the Railroad in TRIPLICATE and copy to the Department as evidence with respect to the operations performed for it by any subcontractor who carries, in their own behalf, regular Contractor’s Protective Public Liability Insurance and regular Contractor’s Protective Property Damage Liability Insurance both providing for limits of not less than \$2,000,000.00.

The insurances of the Utility and its contractor(s), in 1 and 2 above, shall contain a contractual liability endorsement which will cover the obligations assumed under the utility permit and an endorsement naming the Department as “additional insured”. This endorsement provision shall be stated on the certificate of insurance provided to the Department and copy to the Railroad.

CERTIFICATE HOLDER for 1 and 2 above is as follows:

COPY TO:

Railroad	State Utilities Engineer
[Information to be provided	GA. DOT/Office of Utilities
During the permit review	600 West Peachtree St.
process]	10 <sup>th</sup> Floor
	Atlanta, Ga. 30316

CERTIFICATE OF “ADDITIONAL INSURED” for 1 and 2 above is as follows:

Georgia Department of Transportation  
 Administrator, Office of Intermodal Programs  
 600 West Peachtree St.  
 2nd Floor  
 Atlanta, Ga. 30316

3. Railroad Protective Liability Insurance - The Utility shall furnish to the Railroad and copy to the Department the ORIGINAL AND TWO (2) COPIES of Railroad Protective Insurance Policy with limits of liability as follows:

COVERAGE	<u>MINIMUM COMBINED LIMITS OF LIABILITY</u>
Bodily Injury Liability ] \$2,000,000.00 per occurrence	
Property Damage Liability ]	\$6,000,000.00 aggregate
Physical Damage to Property ]	

The Standards for this protective insurance shall follow the requirements of Part 646, Subpart A, of Title 23, Highways, of the Code of Federal Regulations (CFR), current edition.

Railroad protective insurance shall be provided on “ISO-RIMA” (Insurance Services Office - Railroad Insurance Management Association) policy form No. CG 00 35 01 96. ISO Amendatory Endorsement No. CG 28 31 10 93 should also be included if a policy form number other than the foregoing is used. The equivalent of the foregoing will also be acceptable. Such insurance shall contain a contractual liability endorsement which will cover the obligations assumed under this utility permit and an endorsement naming the Department as “additional insured”. This endorsement provision shall be stated on the certificate of insurance provided to the Department and copy to the Railroad.

BINDERS ARE NOT ACCEPTABLE FOR THIS COVERAGE

A. Evidence of insurance as required shall be furnished to the address shown below for review and approval by the Department and copied to the Railroad:

COPY TO:

Railroad	State Utilities Engineer
[Information to be provided	GA. DOT/Office of Utilities
During the permit review	600 West Peachtree St.
process]	10 <sup>th</sup> Floor
	Atlanta, Ga. 30316

B. All insurance specified shall be carried until all utility work required under the terms of the permit has been satisfactorily completed within the limits of the right-of-way as evidenced by the formal acceptance of the Department and the Railroad. Insuring companies may cancel insurance by permission of the Department and Railroad or on 30 days written notice to the Department and Railroad as follows:

COPY TO:

Railroad  
[Information to be provided  
During the permit review  
process]

State Utilities Engineer  
GA. DOT/Office of Utilities  
600 West Peachtree St.  
10<sup>th</sup> Floor  
Atlanta, Ga. 30316

**7.10 PLANS TO ACCOMPANY PERMIT APPLICATION**

In addition to the requirements in Chapter 3 of this Manual, the Utility shall indicate on the plans the horizontal and vertical clearances of the proposed facility to the tracks and other information necessary to evaluate the impact to the Railroad's operation and the right-of-way.

**7.11 APPROVAL PROCESS**

**7.11.A. District Utilities Office Review** - Permit applications shall be submitted by the Utility utilizing the GUPS to the respective District Utilities Engineer for review and recommendation and shall contain as a minimum the following information: The proposed plan showing in detail the location of the proposed facility. The plans shall include the operating Railroad name, nearest Railroad milepost and intersecting public road; show the size, material, pressure (if applicable), capacity, etc. of facilities to be installed; casing material, size, thickness, length; features such as right-of-way lines; horizontal and vertical clearance to top of rail and any other information necessary to evaluate the impact to the right-of-way. Include a location sketch (County map) showing the work site. Upon the completion of the Districts review, the application shall be forwarded to the State Utilities Office for further processing and final approval.

**7.11.B. State Utilities Office Review** - Upon receipt, the State Utilities Office shall review the permit for compliance and submit a Utility Permit Special Provision for Protection of Railway Interests (see GDOT's Utilities webpages) to the District Utilities Office to forward to the Utility for completion. The Utility shall address each stipulation in the Special Provision and forward the complete permit package to the District Utilities Office. The District Utilities Office will forward the completed permit package back to the State Utilities Office for final review. The State Utilities Office shall notify the District Utilities Office of the conditional approval

upon receipt of the 10 day notice of intent to begin work to the Department and operating Railroad. At this time the District Utilities Office will approve the permit and send one original copy to the State Utilities Office and hold all other copies until notified from the State Utilities Office that the 10 day notice has been received.

## **7.12 NOTICES**

- 7.12.A. Notice of Work Beginning** - The Utility will be required to give the Department and Railroad at least 10 working days of advance notice of intent to begin work within the Department owned Railroad right-of-way. Once begun, when such work is then suspended at any time, or for any reason, the Utility will be required to give the Railroad Representative at least 3 working days of advance notice before resuming work on Department owned Railroad right-of-way. Such notices shall include sufficient details of the proposed work to enable the Railroad Representative to determine if flagging will be required. If such notice is in writing, the Utility shall furnish the State Utilities Engineer a copy; if notice is given verbally, it shall be confirmed in writing with copy to the State Utilities Engineer. If flagging is required, no work shall be undertaken until the flagman, or flagmen, are present at the job site. It may take up to 30 days to obtain flagging initially from the Railroad. When flagging begins, the flagman is usually assigned by the Railroad to work at the project site on a continual basis until no longer needed and cannot be called for on a spot basis. If flagging becomes unnecessary and is suspended, it may take up to 30 days to again obtain flagging services from the Railroad. Due to Railroad practices, in some cases it may be necessary to give 5 days notice before flagging service may be discontinued and payment stopped.
- 7.12.B. Notice of Work Completion** - The Utility shall notify in writing to the Department and Railroad when the installation authorized by the permit has been completed to ensure that provisions of the permit have been met and all areas within the right-of-way have been adequately restored.
- 7.12.C. Notice of Maintenance Work** - The Utility shall give advance notice to the Department and Railroad prior to performing maintenance of their facilities as per Section 7.12.A of this Manual.

### **7.13 EXCEPTIONS**

Permit Applications that do not meet the minimum criteria set forth in this Manual shall be reviewed by the State Utilities Engineer, Office of Intermodal Administrator, and the Operating Railroad.

### **7.14 FAILURE TO COMPLY**

In the event the Utility violates or fails to comply with any of these requirements or any requirements in the Utility Permit Special Provision for Protection of Railway Interests (see GDOT's Utilities webpages), the Department's Inspector/Area Engineer and/or the Railroad Representative may require that the Utility vacate the Department owned Railroad right-of-way.

Any such orders shall remain in effect until the Utility has remedied the situation to the satisfaction of the Department's Inspector/Area Engineer and/or the Railroad Representative.

### **7.15 POLICY ON RELOCATION**

- 7.15.A. Authority to Order Removal and Relocation** - In addition to the requirements in Chapter 2 of this Manual, the Department reserves the right to require the Utility to remove, repair, adjust, or relocate any utility facilities installed within the Department owned Railroad right-of-way which the Department or Lessee has undertaken to improve, or intends to improve. When, in the opinion of the Department, the facility constitutes an obstruction or interference with the use or safe operation of such Railroad and/or will interfere with such construction, maintenance, or operations, the removal, relocation, or adjustment of utilities shall be accomplished at the sole expense of the Utility except as it may qualify for reimbursement under the provisions of Chapter 4 of this Manual.

**This Page Intentionally Left Blank**

## CHAPTER 8: UTILITY POLE SAFETY PROGRAM

### 8.0. GENERAL

The Department has the responsibility to work with pole owners to develop and implement programs to systematically remove, relocate, or mitigate hazardously located utility poles in a reasonable, cost-effective manner as per the provisions of 23 CFR Part 645.209(k).

The Utility Pole Safety Program sets guidelines to reduce the potential for pole crashes and assist Utility companies, State, and Local transportation professionals in targeting the most hazardous poles for removal/relocation/mitigation. The cost to relocate poles is staggering. However, it is conservatively estimated that an appropriately funded program will yield very cost effective safety improvements. The safety improvements concept is based strictly on the probability that a crash will be reduced based on the further an object is from the roadway (see Chart 8-1).

**Reduction Due to Increasing Lateral Pole Offset**

Pole Offset Before Relocation (ft) <sup>(1)</sup>	Expected Reduction in Utility Pole Crashes (Reduction Factor) <sup>(2)</sup>													
	Pole Offset After Relocation (feet) <sup>(3)</sup>													
	3	4	5	6	7	8	9	10	11	12	13	14	15	20-30
1	0.87	0.88	0.89	0.90	0.90	0.91	0.92	0.93	0.94	0.95	0.95	0.97	0.97	0.98
2		0.75	0.76	0.77	0.79	0.80	0.82	0.83	0.84	0.87	0.88	0.90	0.90	0.92
3			0.63	0.65	0.67	0.69	0.71	0.73	0.75	0.79	0.80	0.82	0.83	0.85
4				0.4	0.42	0.5	0.55	0.6	0.63	0.69	0.7	0.72	0.73	0.77
5					0.4	0.4	0.5	0.56	0.59	0.65	0.67	0.69	0.7	0.74
6						0.3	0.36	0.43	0.48	0.55	0.57	0.6	0.62	0.67
7							0.22	0.31	0.37	0.46	0.48	0.52	0.54	0.59
8								0.22	0.29	0.39	0.42	0.45	0.48	0.55
9									0.18	0.3	0.33	0.37	0.4	0.48
10										0.22	0.25	0.3	0.33	0.42
11											0.18	0.24	0.27	0.36
12												0.11	0.15	0.25
13													0.11	0.22
14														0.17

Source: Federal Highway Administration. Report Number FHWA/RD-82. Volume II. Final Report. "Cost-Effectiveness of Countermeasures for Utility Pole Crashes." Washington: January 1983. Page 82. Table 23.

- (1) Distance from edge of pavement to existing face of pole
- (2) Reduction of Utility Pole Crashes resulting from relocation
- (3) Distance from edge of pavement to new pole location

**Example:** If the existing pole is to be relocated from 4 feet to 10 feet, you can expect a 60% reduction in the number of Utility Pole Crashes.

Chart 8-1

## **8.1 FUNDAMENTALS**

**8.1.A. Objective** - This multifaceted approach includes treating isolated problem locations and high risk sites, as well as preventing the development of new high risk sites, and includes systematic reviews and treats high risk corridors. This is generally a long range, systemic approach that requires steady and consistent application to ensure effective use of the time and cost involved to meet this objective. The opportunities for application range from initial design of new facilities, road widening projects, and utility rehabilitation, to even smaller projects such as those where turn lanes are built by developers with private funding.

**8.1.B. Goals** - While removing all utility poles is preferable in order to reduce the number and potential for future utility pole crashes, in some cases, it may not be feasible to remove or relocate all existing utility poles from the clear zone. However, it may be possible to lessen the risk of a future pole crash by utilizing the following Four Key Plan Elements. These Four Key Plan Elements help identify locations that will be part of the Department's permitting and safety efforts. It does not expand or allow poles to be located in areas previously prohibited, such as limited access, medians, gore areas, etc. These Key Plan Elements will apply in curb and gutter and rural shoulder sections and apply to any above ground fixed utility object sufficient to cause serious damage upon impact by an errant vehicle.

### **Four Key Plan Elements**

- 1. Crash Data** - This element addresses the locations that have crash problems or are recognized as high risk locations. The application of this key element is limited to a single pole or a few poles. This element will be addressed by increasing the Utility Industry's awareness of fatal crashes that involve utility poles by reviewing crash reports with pole owners.
- 2. Relocation** - This element targets specific poles located in 3 mile sections. The sections will have a history of pole crashes (responsive), or are in locations where the risk of future pole crashes is likely (pro-active). The mechanism for identifying the locations will be through the utility pole crash database. In a joint effort the Department will use Safety Funds (when available) to assist Utility Companies with the relocation or mitigation of the poles.
- 3. Existing Facilities** - This element involves developing and implementing policies that prevent placing (or replacing) poles within the clear zone area along streets and highways during betterment, rehabilitation or reconstruction of existing Utility facilities. This element will require a two-pronged approach: first, a categorization, which will be based on



utility poles having crash history in certain sections of areas being rehabilitated; and, second, a determination, which will be based on the number of poles being added or replaced on the rehabilitated section.

4. **New Facilities** - This last element will address all new requests for Utility facilities involving utility poles on State Right-of-Way. All provisions of this Manual and/or the AASHTO *Roadside Design Guide*, current edition, will be utilized for an effective permit process that prevents the installation of utility poles in hazardous locations.

## **8.2 REQUIREMENTS**

The Department, in a joint effort with the GUCC, has endeavored to develop policies to help reduce crashes involving utility poles. The Department and the Utilities have considered several alternatives for treating high crash locations. To attend to the four Key Plan Elements listed above to help prevent future installations and/or remove existing utility poles in current hazardous locations, the Department will address and/or review utility permit requests with the following requirements:

**8.2.A. Crash Data** - The State Utilities Office will review all crash reports involving utility poles when a fatality occurs. If the utility pole is a primary factor in the crash, the State Utilities Office will then notify the pole owner that a site visit may be required. Upon performing the site visit, the pole owner and the State Utilities Office will formulate a Relocation or Mitigation Plan for the pole or poles for the area in question.

**8.2.B. Relocation** – This is a proactive effort by participating Utilities to address high crash locations within their service area. The Department may assist in funding relocation of poles based on crash data for selected utility projects when safety funds are available. The Department will review crash data of high risk locations based on the crash history as determined by the utility pole crash database. Then, a 3 mile section of a State Highway will be selected in which a utility project will be programmed and funding provided on a 50/50 cost ratio. Agreements will be eligible for reimbursement under the classification for Case V and shall be prepared in accordance with Chapter 4 of this Manual.

After a utility project is programmed, the Utility Companies and the State Utilities Office will conduct a site inspection along the selected 3 mile section. An assessment will then be made, jointly, to determine whether or not relocating utility poles along this selected route will improve the overall safety.

If the route has a variety of obstacles, such as buildings and trees in addition to the pole line, the project may be referred to the District Traffic Operations Office for consideration as a “corridor improvement project”. The State Utilities Office will then select the next project for consideration from the Utility Pole Crash Database. These efforts target existing poles found in hazardous locations which would see a measurable improvement of safety by relocating the poles, and where, in these cases, the poles are necessary and there are no alternatives to serve the purpose of the poles. The utility projects selected shall be in locations that have a history of pole crashes, where the risk of future pole crashes are likely, and where the safety on the route would improve drastically by relocating the existing poles.

**8.2.C. Existing Facilities** - All existing utility facilities located on State Highways shall be allowed to stay in their current location, unless, as part of a Utility betterment, rehabilitation or reconstruction of existing facilities, the utility permit for the facility shall be reviewed to verify if one of the following two conditions exist:

**8.2.C.1. Major Rehabilitation or Reconstruction (Category 1)** - If a major betterment, rehabilitation, or reconstruction project is being performed by the Utility pole owner, and a net total **equal to or greater than 33%** of the total number of poles that are being affected or planned to be replaced, or additional poles are being added due to larger wire diameter and/or distance requirements, or taller poles are being installed for additional utility clearance requirements, the Utility shall be required to relocate all the poles in the permit request to meet current clear roadside requirements shown in this Manual, current edition and/or the *AASHTO Roadside Design Guide*, current edition. Projects of two poles or less are exempt from this requirement. (See Table 8.2.C below).

**8.2.C.2. Major Rehabilitation or Reconstruction (Category 2)** - If a major betterment, rehabilitation, or reconstruction project is being performed by the Utility pole owner, and a net total of **less than 33%** of the total number of poles that are affected or planned to be replaced, or additional poles are being added due to larger wire diameter and/or distance requirements, or taller poles are being installed for additional utility clearance requirements, the project route will be reviewed for crash history. Where crash data for the pole line in question shows an average of one crash per mile per year for the last three (3) years of data available, and where the existing pole locations do not meet the current clear zone requirements, the

pole owner will be required to relocate the section of poles or use approved mitigation methods. (See Table 8.2.C below)

Total Number of Poles being Added or Replaced							
	0	1	2	3	4	5	6
Total Number of Poles on Project  (Along GDOT roadway)	1	*Exempt	--	--	--	--	--
	2	*Exempt	*Exempt	--	--	--	--
	3	*Exempt	*Exempt	MMC	--	--	--
	4	*Exempt	*Exempt	MMC	MMC	--	--
	5	*Exempt	*Exempt	MMC	MMC	MMC	--
	6	*Exempt	*Exempt	MMC	MMC	MMC	MMC
	7	*Exempt	*Exempt	MMC	MMC	MMC	MMC
	8	*Exempt	*Exempt	MMC	MMC	MMC	MMC
	9	*Exempt	*Exempt	MMC	MMC	MMC	MMC
	10	*Exempt	*Exempt	*Exempt	MMC	MMC	MMC

Table 8.2.C: Note: **Exempt** means able to retain poles in existing location (\*crash data evaluation required) and **MMC** means poles Must Meet Clearzone. Only mainline poles along the GDOT roadway are to be included in the total number of poles for this calculation.

This table is not all inclusive; if a project exceeds examples above use Sections 8.2.C.1 or 8.2.C.2 as applicable.

**8.2.D. New Facilities** - All new utility facilities permitted for installation on right-of-way shall be required to meet current clear zone requirements as shown in this Manual, current edition and/or the AASHTO *Roadside Design Guide*, current edition. Permissible locations and standards for these installations are included in Chapter 5 of this Manual.

### 8.3 MITIGATION POSSIBILITIES

The most desirable design solution, in terms of roadside safety, is to use as few poles as is practical and to locate the utility poles where they are least likely to be struck by a vehicle. Even so, there will be locations where the Utility and the Department agree there is no feasible way to accomplish this goal and other countermeasures must be considered to mitigate or reduce the number and severity of crashes with utility poles and above ground utility appurtenances. The following are some options that should be consider:

A. **Increase Pole Spacing** - The spacing between utility poles differs depending upon the type of utility and the general practices of the specific company, but should be maximized where possible. As poles are placed farther apart, the openings that will allow a vehicle to pass

through without striking a pole become larger. When placing service poles (either short side or long side connections) for an individual or company, the service pole should be placed off the right-of-way with the actual service connection being made to an existing pole. The placing of mid-span poles and service poles just behind the pole line should be discouraged.

- B. **Combine Pole Usage with Multiple Utilities** - Although the Department's current policies dictate a single pole line, they cannot stipulate that poles be placed off the right-of-way (some conditions may prohibit the distance from right-of-way). If a pole line exists on the right-of-way, efforts should be made between the Utilities to either relocate the existing line with the new facility or rebuild the current facility to accommodate both facilities.
- C. **Bury Electric and Telecommunication** - As pertaining to electrical lines, rarely would burying the facility be proven to be a cost effective solution to existing facilities, but may be justified in new design or for aesthetic considerations. As for telecommunication facilities, burying the facility underground is an option that should be approached to remove pole lines in hazardous locations.
- D. **Change Pole Position** - Although the most direct solution is to remove the utility pole or poles, this is often not practical, but relocating the pole(s) to a location where they are less likely to be struck should be encouraged. Each site may give natural locations to which a pole(s) can be located (e.g., behind a ditch, existing guardrail, up a slope or on the inside of a curve). These natural or pre-existing locations should be utilized to reduce impacts.
- E. **Breakaway Poles** - The application of breakaway devices is a strategy directed at reducing the severity of the pole crash. The unforgiving nature of a utility pole contributes to the severity of the crash by causing vehicles to rapidly decelerate. Breakaway poles allow the vehicles to pass through the pole and, therefore, the vehicle will not absorb as much energy. While there are several designs and techniques for breakaway devices, only the Steel Reinforced Safety Pole was specifically designed for utility poles. Some of the criteria for use of a breakaway device are that the pole is a class 4-40 or smaller and does not have heavy devices attached. There is a safe recovery area behind this type of pole so that the pole(s) is not located near a zone of significant pedestrian traffic which, if the pole(s) was hit, would create a hazard for pedestrians, other vehicles, and adjacent property owners. The Utility shall be responsible for the determination of the use of breakaway poles.
- F. **Guardrail** - The purpose of guardrail is to redirect errant vehicles away from a roadside hazard so drivers may regain control of the vehicle or arrive at a safer stop than what would be provided by striking the hazard. Shielding drivers from poles is a proper use of guardrail when the alternatives for removing and/or relocating the poles are not practical due to right-of-way constraints, roadside environment, or economics. The guardrail and the end treatments or barrier should not create a greater hazard than the pole and will prevent vehicles from being redirected into a more hazardous roadside area or situation.
- G. **Crash Cushions** - Crash cushions ranging from simple effective sand-filled barrels to more sophisticated devices are available. Where space is available, sand-filled barrels are cost effective solution, but will need to be maintained by the Utility.
- H. **Warning Motorists of Obstacles** - The number of crashes and the severity of crashes may sometimes be decreased by warning motorists of the presence of poles adjacent to the

roadway. This may be done with warning signs, reflective paint, object markers placed on utility poles, or roadway lighting. It is considered a last resort in some cases where more comprehensive treatments are not practical.

#### **8.4 EXCEPTIONS FOR EXISTING & NEW FACILITIES**

Conditions may arise or exist in the field that make it impractical or cost preventive to comply with a particular policy or standard. Where compliance with a policy or standard is impractical, an “Exception” must be obtained. Exceptions are not to be interpreted as compromising safety or quality. Where the Utility feels that the normal policies or standards are not practical, the Utility bears the responsibility of demonstrating that alternative treatments are more appropriate. This must first be accomplished by demonstrating to the District Utilities Engineer that an exception is warranted. If the District Utilities Engineer feels that an exception should be granted, a formal written request, including all of the appropriate documentation, plans, and complete permit application, will be sent to the State Utilities Office stating the recommendation. This information should clearly indicate the exact exception that is being requested (i.e. what condition does not meet the minimum criteria set forth in this Manual or the *AASHTO Roadside Design Guide*) and what alternative action is being proposed. The request shall then be reviewed by the State Utilities Engineer for approval or denial. If the exception is denied by either the District Utilities Engineer or the State Utilities Engineer and, in the opinion of the Utility, alternates are not feasible, and then the Utility may appeal the denial to the GUCC Clear Roadside Committee (CRC) for review. The Committee will review the Utility Companies exception request and make a recommendation to the Department for a final ruling. If federal funds are involved, the Department will refer to the FHWA for review and approval of any exception request.

#### **8.5 PARTICIPATION**

The Department encourages Utilities with existing aerial facilities to participate in the Utility Pole Safety Program by signing an Memorandum of Understanding stating that they will participate in all of the Four Key Plan Elements that have been agreed to between the GUCC and the Department for their utility facilities in their service area, and/or stating that they will transfer their facilities in a timely manner. In the event the Utility elects not to participate in the Utility Pole Safety Program, all future permit requests shall meet the current clear roadside requirements set forth in this Manual or the *AASHTO Roadside Design Guide*, current edition.

**This Page Intentionally Left Blank**

## **CHAPTER 9: BROADBAND DEPLOYMENT**

### **9.0 GENERAL**

Broadband has become essential to business, education, healthcare, agriculture, and overall quality of life. Unfortunately, high-speed internet access remains unavailable for Georgians in many rural communities. The Department supports statewide efforts to facilitate deployment of essential Broadband Services in unserved and underserved areas so that all Georgians can have improved access to quality healthcare, enhanced educational resources, essential small business resources, and an attractive quality of life.

The Department has the responsibility of partnering with Federal, State, and Local agencies as well as other stakeholders to ensure the mission and intent of this chapter is achieved. It is the intent of this chapter to comply with Federal and State efforts to achieve this common goal. Statutory guidance and support for both Federal “Broadband Infrastructure Deployment” and State “Georgia Broadband Deployment Initiative” can be found by referencing 23 CFR 645 Subpart C pursuant to 47 U.S.C. 1504 and O.C.G.A. § 50-40 respectively. The following prescribes policies, procedures, standards, and practices for the statewide coordination efforts of broadband deployment within transportation projects.

### **9.1 BROADBAND INFRASTRUCTURE DEPLOYMENT**

On March 23, 2018, the “MOBILE NOW Act” was signed into law as a part of the Consolidated Appropriations Act, 2018. Section 607 “Broadband Infrastructure Deployment” (47 U.S.C. 1504) required FHWA to develop regulations to ensure that States meet specific registration, notification, and coordination requirements to facilitate broadband infrastructure deployment in the ROW of applicable Federal-aid highway projects. On December 3, 2021, the FHWA published a final rule (23 CFR 645 Subpart C) prescribing additional requirements to facilitate the installation of Broadband Infrastructure. The following sections outline the Department’s procedures in compliance with the rule.

**9.1.A. Broadband Utility Coordinator** – The Department’s SUO Liaison will also serve as the statewide Broadband Utility Coordinator (BUC) and is responsible for facilitating the broadband infrastructure right-of-way efforts within the State.

The BUC will coordinate initiatives carried out under Section 9.1 with other statewide telecommunication and broadband plans and State and local transportation and land use plans, including strategies to minimize repeated excavations that involve the installation of broadband infrastructure in a right-of-way.

The BUC will also be the primary point of contact for broadband infrastructure project related questions from any Broadband Infrastructure Entity and the DUO.

**9.1.B. Registration of Broadband Infrastructure Entity -** Broadband Infrastructure entities desiring to be included in Broadband Infrastructure right-of-way facilitation efforts within the State can register by visiting the Office of Utilities webpages on the Department’s website. Under the Broadband Infrastructure Deployment section, select the “Broadband Entity Registration Form”. Once completed, the Broadband Infrastructure Entity will submit the form based on instructions given at the time of registration. Once the request is approved, the entity will be indicated as a Broadband Infrastructure Entity in the Department’s database and/or Georgia Utility Permitting System (GUPS). A list of registered Broadband Infrastructure Entities will be published on the Department’s website.

**9.1.C. Notification of Projects in the STIP -** The Department publishes the Statewide Transportation Improvement Program (STIP), which is Georgia’s four-year transportation and capital improvements program. The STIP lists federally funded transportation projects that are located outside Metropolitan Planning Organization (MPO) boundaries. Each MPO develops its own Transportation Improvement Program (TIP). The TIPs are included in the STIP by reference without modification once approved by the MPO and the Governor, or his designee. Projects include highway, bridge, public transit, bike, pedestrian, railroad, and other improvements.

Annually, Broadband Infrastructure Entities registered in accordance with Section 9.1.B. of this manual, will receive electronic notification of projects included in the STIP. When necessary additional notifications will be sent so that Broadband Infrastructure Entities remain informed of projects supporting Broadband Infrastructure Deployment in the State.

**9.1.D. Coordination and Collocation Efforts -** The statewide BUC will coordinate the initiatives carried out in Section 9.1 with other statewide telecommunication and broadband plans and State and local transportation and land use plans to include the “Georgia Broadband Deployment Initiative” so that Federal and State broadband efforts are carried out in close coordination.

The Department is an advocate for Collocation efforts as demonstrated in Section 5.11.B.2. of this manual. The statewide BUC will communicate this intent to all stakeholders.



## **CHAPTER 10: DESIGN-BUILD (DB) AND PUBLIC PRIVATE PARTNERSHIP (P3) PROJECTS**

### **10.0 GENERAL PROVISIONS**

**10.0.A. Scope & Purpose** – Although it is impractical to include all policy interpretations and instructional materials, this Chapter sets forth general information and certain specific Utility obligations necessary for the performance of Utility Adjustment Work in the context of Design-Build (“DB”) projects and Public-Private Partnership (“P3”) projects, (“DB/P3 Projects”) in Georgia.

In DB/P3 Projects, the “Design-Builder” (for DB projects) or the “Developer” (for P3 projects) will undertake, manage, and perform certain processes, activities and obligations that are customarily the Department’s responsibility in traditional design-bid-build projects. In this chapter, Contractor will refer to Design-Builder and Developer, as applicable. DB/P3 projects are developed and implemented by the P3 Division of the Department and the P3 Division of the Department will interface with Utility Owners regarding these projects.

While the Manual broadly covers information for utility facility accommodation and Department/Contractor/Utility Owner coordination generally, including for DB/P3 Projects, the information covered in this chapter is specific to DB/P3 Projects. Accordingly, this chapter is to be read with the remainder of the Manual.

**10.0.B. Background and Context: Public Interest Determination and Utility MOUs** - Pursuant to O.C.G.A. §§ 32-6-170(a) and (b), the Department is authorized to pay or participate in the costs of removal, relocation, or adjustment of utility facilities necessary to accommodate the construction or maintenance of a public road by the Department where there has been a determination that it is in the public’s best interest. To minimize construction coordination conflicts, for non-DB/P3 projects, the Department makes a determination on an individual project basis about whether it is feasible to include utility adjustments in the roadway construction contract. See Section 4.1.C.3. For all DB/P3 projects, the Department has made an

automatic Public Interest Determination (PID), authorizing the Department (1) to pay or participate in the costs for Utility Adjustment Work as part of the contract for all DB/P3 Projects and (2) to include the scope of Utility Adjustment Work in the DB/P3 contract. PID applies, such that the Department is authorized to pay for costs of Utility Relocations included in the contract, to any utility facilities without regard to whether such facilities were originally installed upon rights of way of the state highway system, a county road system, or a municipal street system. Separately, O.C.G.A. § 32-6-172 and § 32-6-173 authorize the Department to pay for costs of Utility Relocations where the Utility has established prior rights.

When there has been a PID, a clear definition of the requirements of the Utility for approval of the work and a clear definition of the scope of any materials and services to be provided by the Utility Owner must be set out in a Memorandum of Understanding (MOU). The Department provides the Utility Owner with a standard DB or P3 MOU form on which the Utility Owner elects and agrees to the assignment of responsibilities and indicates whether the design and construction of the Utility Adjustment Work shall be carried out:

1. By the Utility Owner under a Standard Utility Agreement with the Department

OR

2. By the Contractor under the DB/P3 Contract, either as

Option 1: Utilizing the Utility Owner's pre-approved design consultants and contractors

OR

Option 2: Utilizing the Contractor's own design consultants and contractors

When the Utility Owner elects that Utility Adjustment Work shall be carried out by the Contractor, it shall indicate any exceptions – those work items to be performed by the Utility Owner under a Standard Utility Agreement with the Department.

The Utility Owner is required to return the executed MOU to the Department's P3 Division. The Department will review the proposed assignment of responsibilities and, upon approval, execute and return a fully executed counterpart of the MOU to the Utility Owner. This Memorandum will subsequently serve as the basis for proceeding with inclusion of the work in the contract.

Utility MOUs will be available to the bidding Contractors during the procurement of a DB/P3 Project.

- 10.0.C. Reliance** - The Utility Owner acknowledges that its performance of the activities that are described in this chapter, strictly in accordance with the timing specified and in related documentation referenced in this chapter, as well as the activities described in the Utility MOUs), is necessary to enable the Contractor to satisfy its related obligations under the DB/P3 Contract.

### **10.1 RESPONSIBILITIES OF UTILITY OWNERS AS RELATES TO DB/P3 PROJECTS**

The following sets forth the obligations of Utility Owners to the Department and Contractors as relates to DB/P3 Projects and is organized generally based on (1) pre-award/project development obligations, (2) utility self-performance (3) DB/P3 Contract-related requirements and obligations, and (3) obligations related to utility adjustment plans.

- 10.1.A. Obligations in Connection with Project Development (Prior to Award of DB/P3 Contract)** - The Utility Owner shall be obligated to performing the following in connection with the efforts of the Department, and any of its designees, in preparation for and development of DB/P3 Projects prior to award:

- a. Completing the Utility MOU in accordance with Section 10.0.B
- b. Cooperating with Department subsurface utility engineering (“SUE”) and Department/Utility Owner coordination efforts (including with Department’s designees). The identification of existing facilities including preparation of SUE investigations plans will be accomplished by the Department prior to award of the Contract and thereafter supplemented by the Contractor
- c. Completing the GDOT DB/P3 project utility analysis form (generally, an assessment by each Utility Owner as to what utility facilities exist and where they are located within the DB/P3 Project limits) prior to a date identified by the Department to the Utility Owner, in accordance with existing duration timelines for project delivery set forth in this Manual, for the purpose of providing bidding Contractors consistent information, in addition to the MOUs and SUE plans, and to reduce inquiries made by the proposing Contractors to Utility Owners during the procurement
- d. If the Utility Owner has received a letter and set of preliminary plans for the DB/P3 Project from the Department, providing written or e-mail confirmation acknowledging receipt of the plans

AND

- e. Attending the project development utility workshop to verify that the preliminary plans correctly show existing and proposed locations of utility facilities

**10.1.B. Utility Owner Self-Performance** - For those elements of Utility Adjustment Work that the Utility Owner elects in the MOU to self-perform under a Standard Utility Agreement, rather than for the Contractor to carry out under the DB/P3 Contract, the Utility Owner is obligated under O.C.G.A. § 32-6-170 and § 32-6-171 to submit a utility work plan and comply with the approved utility work plan. For a DB/P3 project that work plan shall be submitted in accordance with Section 9.1.4(b).

**10.1.C. Obligations in Connection with the DB/P3 Contract** - The Utility Owner shall perform the following obligations in connection with the Contractor's performance under the Contract as relates generally to interfaces with the Utility Owner's utility facilities.

**10.1.C.1. Required Meetings** - Utility Owners shall attend the utility "kick-off" meeting and Department/Contractor/Utility Owner coordination meetings in the manner scheduled by the Contractor. If any Utility Owner is unable to attend any such meetings, the Utility Owner shall coordinate with the Contractor to agree on a mutually convenient alternative date, time and/or location for such meeting. The Utility Owner shall ensure that appropriate Utility Owner-affiliated personnel attend any such meetings, including with the requisite authority and background knowledge necessary to address items on the Contractor's agenda related to such Utility Owner.

**10.1.C.2. Real Property Matters** - Utility Owners shall have the following obligations regarding existing and new interests:

- a. Provide to the Contractor and to the Department such documentation of any right, title, or interest in real property (e.g., a fee or an easement) claimed by a Utility Owner as the source of its right to maintain an existing utility facility in such real property, which is compensable in eminent domain ("Existing Interest"), establishing and substantiating the same on or prior to election to prepare the Utility Adjustment Plans ("UAPs")

- b. Based on the Contractor's design, provide to the Contractor written notification of a decision to acquire any permanent right, title or interest in real property outside of the DB/P3 Project's geographic limits (e.g., a fee or an easement) that is acquired for a utility facility being reinstalled in a new location as a part of the Utility Adjustment Work (excluding any statutory right of occupancy or permit granted by a governmental entity within its real property) (a "New Interest") within 10 Business Days after making such decision
- c. If a utility adjustment cannot be accommodated within the existing right of way, then, regardless of whether the Contractor or the Utility Owner takes the responsibility for obtaining the New Interest to accommodate the utility facility outside of the proposed right of way, once the New Interest has been obtained, the Utility Owner shall expeditiously relinquish its Existing Interest in connection with performance of its obligations relating to New and Existing Interests

**10.1.C.3. Emergency Utility Response Information (EURI)** - Utility Owners shall provide to the Contractor a completed EURI form within 30 Business Days after receipt of the draft EURI form from the Contractor.

**10.1.C.4. No Conflict Letter Requirements** - Upon request for confirmation from the Contractor that no conflict exists with its utility within the DB/P3 Project limits, the Utility Owners shall provide to the Contractor a no conflict letter and no conflict GUPS permit within 40 Business Days after receipt of documentation from the Contractor clearly showing no conflict exists.

**10.1.C.5. Verification of Utility Plans and SUE Investigations** - Utility Owners shall confirm the information in the applicable SUE plans in respect of their existing utility facilities or shall provide updates thereto with current and accurate information, within 40 Business Days after receipt from the Contractor.

**10.1.C.6. Utility Retention Request** - Utility Owners shall notify the Department in accordance with Section 2.8.B and will keep the Contractor informed of the status of any such Utility Retention Request.

**10.1.C.7. Utility Work Plans** - Utility Owners shall cooperate and coordinate with the Contractor to provide information needed by the Contractor to prepare utility work plans and to execute any required modifications, on a timely basis, as may be requested by the Contractor.

**10.1.C.8. Utility Facility Relocation Acceptance Form** - Utility Owners shall execute any "Utility Facility Relocation Acceptance Form" (as defined in the Contract and as contemplated under the Utility MOU) within 10 Business Days after receipt thereof from the Contractor.

**10.1.C.9. General Obligations** - In the context of DB/P3 Projects, the Utility Owner shall perform the following obligations as it relates to its utility facilities in Georgia:

- a. Coordinate and cooperate with the Contractor, Utility Owner's pre-approved design consultants, and Utility Owner's pre-approved contractors in the same manner that it does with the Department, before and after the Department awards the DB/P3 Project, and in each case, in a manner consistent with the terms of the Utility MOU
- b. Cooperate with the Contractor and Department to the identification of additional pre-approved design consultants or pre-approved contractors, if necessary
- c. Provide prompt written confirmation to the Contractor acknowledging the receipt of all DB/P3 Project information requests and timely responses to such requests
- d. Timely inspect, provide feedback on and ultimately accept any Utility Adjustment Work performed by the Contractor
- e. Submit any required GUPS permits, retention requests, real property documents, and UAS's as required  
and
- f. Complete and timely perform any required Utility Adjustment Work reserved to the Utility Owner or agreed to be performed by the Utility Owner (including design, construction, removal, relocation, adjustment, protection, or otherwise as relates to the Utility Owner's utility facilities) in accordance with the UAPs (and UAS specifically)

**10.1.D. Obligations in Connection with Utility Adjustment Plans** - Utility Owners shall prepare UAPs for those services they have reserved

under the relevant Utility MOUs in accordance with the requirements of this chapter and the UAM. Contractors shall prepare all other UAPs, and Utility Owners shall cooperate with the Contractor regarding the Contractor's UAP, and the Contractor's other work as relates to the Utility Owner's performance of its UAPs.

**10.1.D.1. Utility Adjustment Plans Prepared by Contractors** - Utility Owners shall review and approve any preliminary and final UAPs prepared by the Contractor and submitted to the Utility Owner within 30 Business Days after receipt thereof. Should there be any changes to the UAP by the Contractor, the Utility Owner shall cooperate and coordinate with the Contractor to provide written approval of such changes on a timely basis.

**10.1.D.2. Utility Adjustment Plans Prepared by Utility Owners** - At its election, a Utility Owner shall prepare the UAP in accordance with the requirements of the applicable Utility MOU and the UAM. Any Utility Owner preparing a UAP shall cooperate and coordinate with the Contractor for the completion of such UAP, including, without limitation, by timely addressing any comments received from the Department and providing any requested information in respect thereof as requested by the Contractor. Should there be any changes to the UAP by the Utility Owner, including the utility work plans prepared by the Utility Owner under O.C.G.A. § 32-6-170 and § 32-6-171, the Utility Owners shall cooperate and coordinate with the Contractor to provide written approval of any changes to the previously approved UAP.

**10.1.D.2.a. Utility Adjustment Schedule** - Utility Owners shall cooperate and coordinate with the Contractor to develop and complete the Utility Owner's Utility Adjustment Work Plan in accordance with the corresponding Utility Adjustment Schedule ("UAS") and otherwise on a timely basis, including as may be requested by the Contractor, ensure compatibility of the UAS with the Contractor's overall DB/P3 Project schedule.

**10.1.D.2.b. Utility Adjustment Plans** – Utility Adjustment Plans shall:

1. Meet the applicable requirements of this UAM

2. Reflect all existing utility facilities and indicate remaining, and proposed Utility Adjustment Work to avoid conflicts, in the same vicinity
3. Indicate any approvals required from applicable governmental entities
4. Indicate any approvals required from third parties necessary for such Utility Adjustment Work
5. Include miscellaneous general notes required for coordination of Utility Owners with the Contractor's construction work
6. Include issued GUPS permit numbers
7. Include certification from the Contractor stating that the proposed Utility Adjustment Work, and utility facility, as removed, relocated, or adjusted, will not create a conflict with the DB/P3 Project or another Utility Owner's utility facility
8. Indicate whether the Contractor or the Utility Owner is responsible for the Utility Adjustment Work, consistent with the Utility Owner's elections memorialized in the Utility MOUs and
9. Include accommodations for utility facility crossings and attachments for bridge plans, if applicable

### **10.1.E. Utility Adjustment Work by Utility Owners -**

**10.1.E.1. Design and Construction Requirements** - Utility Owners shall perform Utility Adjustment Work in accordance with the assignment of responsibility in the Utility MOU and the UAP accepted by the Department (other than Utility Adjustment field modifications, as may be accepted by the Department).

**10.1.E.2. Utility Adjustment Field Modification Procedures** - Utility Owners shall cooperate and coordinate with the Contractor to undertake any Utility Adjustment Field Modification applicable to such Utility Owner's utility facilities.

**10.1.E.3. Inspection of Utility Adjustment Work** – Utility Owners shall:



- a. For Utility Adjustment Work performed by the Contractor, perform any final inspection of Utility Adjustment Work within 10 Business Days after receipt of notice from the Contractor that Utility Adjustment Work is completed and ready for final inspection and acceptance

AND

- b. For Utility Adjustment Work performed by such Utility Owners, cooperate and coordinate with the Contractor to allow the Contractor to perform any inspections of Utility Adjustment Work on a timely basis, as may be requested by the Contractor

**10.1.E.4. Utility As-Built Plan Requirements** - Utility Owners shall cooperate and coordinate with the Contractor and provide all information necessary to enable the Contractor to monitor and record as-built information when the Utility Adjustment Work is being self-performed by the Utility Owner.

## **10.2 BETTERMENTS**

Any Betterment requested by a Utility Owner may be identified in a Utility MOU or requested thereafter with respect to a DB/P3 Project.

Among the Department, the Contractor, and the Utility Owner, the Utility Owner will be responsible for all costs relating to any such Betterment, unless the costs are agreed as the Contractor's responsibility in accordance with the betterment agreement, a copy of which betterment agreement must be provided to the Department promptly following execution by both parties. The Department will have no obligation to pay for or otherwise to facilitate any Betterment. The Contractor is not obligated to perform any Betterment. Under no circumstances will the Contractor proceed with any Betterment that is incompatible with the DB/P3 Project or is not in compliance with applicable laws, governmental approvals, or the Contract, including all project schedule deadlines.

## **10.3 PROJECT RELATED DISPUTE RESOLUTION**

Utility Owners and Contractors have a general obligation to coordinate and cooperate with each other under Section 10.1.C. of this chapter and shall endeavor to avoid disagreements, arguments, or controversies in the execution of obligations under the Contract as pertains to

Utility Adjustment Work, regardless of the allocation of responsibility for the Utility Adjustment Work between the Utility Owner and the Contractor under the Utility MOU. If the Utility Owner fails to satisfy its obligations, including, but not limited to, by failing to cooperate; failing to provide required approvals; failing to provide a work plan; or failing to complete the removal, relocation, or adjustment of its facilities in accordance with the work plan, where applicable, then the Utility Owner may be liable for the Contractor's delay costs and damages. The following items only may be recoverable by the Contractor as damages:

- a. Additional direct hourly rates paid to employees for job site labor, including payroll taxes, welfare, insurance, benefits, and all other labor burdens
- b. Documented additional costs for materials
- c. Documented additional equipment costs
- d. Documented costs of extended jobsite overhead (only applicable to a delay claim)
- e. Additional 15 percent of the total of above items: a, b, c, and d, which sum includes home office overhead and profit
- f. Required Bond costs
- g. Subcontractors cost in accordance with above items a, b, c, d, e, and f

The following escalation processes shall be utilized to resolve any matter of dispute between the Contractor and the Utility Owner related to the removal, relocation, or adjustment of utility facilities on the Project, including the Contractor's claims against the Utility Owner for damages or delays, prior to a mediation board hearing for resolution as prescribed in O.C.G.A. § 32-6-171.

For Utility Owner failures to comply with its obligations under any betterment agreement, or for other differences or issues relating to any Betterment, the Contractor and the Utility Owner will seek recourse under the dispute provisions of the betterment agreement and not under this Section 10.3. For those disputes that pertain solely to Betterments, the Department will have no obligation to participate in, facilitate, or otherwise be subject to any remedy for the dispute determined under the betterment agreement.

As provided in O.C.G.A. § 32-6-171, and Section 672-19-.01 et. seq. of the Rules and Regulations of the State of Georgia ("Rules"), disputes that may arise between the Contractor and the Utility Owner concerning matters related to any required Utility Adjustment Work of the Utility Owners' facilities related to the DB/P3 Project shall be resolved in accordance with the following procedures.

**10.3.A. Determining Process for Escalation** - The process used for the escalation of utility disputes on DB/P3 Projects is determined by whether the dispute is related to Utility Adjustment work carried out by the Contractor under the Contract (Section 10.3.B) or by the Utility Owner under a Standard Utility Agreement with the Department (Section 10.3.C).

**10.3.B. Escalation Procedure for Utility Adjustment Work carried out by Contractor in DB/P3 Contract** - These policies and standards further serve to document the practice which the Department will follow in construction of federal-aid projects under its certification acceptance plan with the FHWA, as permitted by Title 23 United States Code (USC) Chapter 1, Sections 101 (e), 106, 117 and Chapter 3, Section 315, and, thereby, eliminate the requirement for Federal reviews of individual Departmental actions on all projects exempt from full FHWA oversight.

**10.3.B.1. Escalation Process Step 1** - If the Contractor determines that the Utility Owner, after the Contractor's diligent efforts, is failing, or has failed to comply with its obligations as set out in this chapter) or if any other issue arises between the Contractor and the Owner with respect to the removal, relocation, or adjustment of the Utility's facilities on the Project, (collectively, under Section 672-19-.02(1) of the Rules, "Disputes"), then the Contractor shall promptly deliver to the Owner, with a concurrent copy to the Department P3 Division and State Utility Office, a written notice setting out the failure, difference, or issue (a "Notice of Potential Dispute" under Section 672-19-.04(1)(a) of the Rules). For clarity, work included in the Contractor's scope is not the Utility Owner's obligation in this Chapter.

The Notice of Potential Dispute must detail efforts to resolve the Potential Dispute to date, the Contractor's assessment as to why such efforts have been insufficient or ineffective, and requesting the Utility Owner to submit a plan to rectify the matter in dispute. After the delivery of any Notice of Potential Dispute, the Contractor will continue to use diligent efforts to pursue resolution. The Department may, but is not obligated to, assist in resolving the Dispute identified in the Notice of Potential Dispute.

The Utility Owner must respond in writing, within 10 Business Days from the date of the Notice of Potential Dispute to the Contractor, with copies to the Department P3 Division and State Utility Office if the issues identified in the Notice of Potential Dispute have not been resolved. The response shall propose a plan to rectify the matter in dispute and otherwise address all the issues identified in the Notice of Potential Dispute.

In some cases, the complexity of the Project may require that a Utility coordination meeting be held to address the issues identified by the Contractor. If the Utility Owner determines that

this is the case, or if the Department directs the same by notice to the Utility Owner, then the Utility Owner's response letter shall include a request to hold a Utility coordination meeting with the Contractor and the Department.

If resolved, any necessary changes agreed to will be documented in writing as appropriate.

**10.3.B.2. Escalation Process Step 2** - If any of the issues identified in the Notice of Potential Dispute are not resolved pursuant to Section 10.3.B.1., then the Contractor may issue a further notice to the Utility Owner and the Department requesting that the Department schedule a further meeting within 20 Business Days thereof with the following participants, at a minimum:

- The Utility Owner Representative
- The Contractor
- The GDOT P3 Division Director (or designee)
- The GDOT State Utilities Administrator (or designee)

In this meeting, the attendees shall review the original Notice of Potential Dispute and any other relevant Project-specific documents, as determined by any of the Contractor, the Department, and the Utility Owner, and attempt to resolve the matter.

The outcome of the meeting will be documented in the Step-2 letter prepared by the Contractor. If damages or delay costs are owed by the Utility Owner to the Contractor, such payment is due within 45 Calendar Days of the letter, unless a petition for mediation is filed.

**10.3.C. Escalation Procedure for Utility Adjustment Work for DB/P3 Project carried out by Utility Owner under Standard Utility Agreement or at Owners Expense** - Disputes related to Utility Adjustment Work on a DB/P3 project, carried out by a Utility Owner under a Standard Utility Agreement may arise where the Utility fails to provide a work plan or fails to complete the removal, relocation, or adjustment of its facilities in accordance with the Work Plan or Revised Work Plan approved by the Department, and the Utility may be liable to the Department or its Contractor for delay costs and damages incurred by the Department or its Contractor growing out of the failure of the Utility to carry out and complete

its work accordingly. In such disputes, the escalation procedures outlined in Section 4.4.C. of this Manual shall be utilized by the Contractor, the Utility Owner, and the Department to resolve such disputes regarding damages or delays prior to requests for payment or such claims being brought forth to a mediation board hearing for resolution as prescribed in O.C.G.A. § 32-6-171 and Rule 672-19, with the following modifications:

**Escalation Step 1 Meeting** - If the Utility determines that a utility coordination meeting is necessary in Step 1, its letter should request a meeting with Contractor, the Department P3 Division, and a representative of the Department State Utilities Office.

**Escalation Process Step 2** – Step 2 will commence upon written notification by the P3 Division rather than the District Construction Engineer. The attendees of the meeting will include, at a minimum:

- The Utility Owner Representative
- The Contractor
- The GDOT P3 Division Director (or designee)
- The GDOT State Construction Engineer (or designee)
- The GDOT State Utilities Administrator (or designee)

Upon the resolution of the dispute, any necessary changes agreed to will be documented in writing as appropriate.

**This Page Intentionally Left Blank**