

OFFICE OF MATERIALS AND TESTING

Testing Management Branch

Laboratory Soil Testing Technician

2022 Study Guide



Testing Management

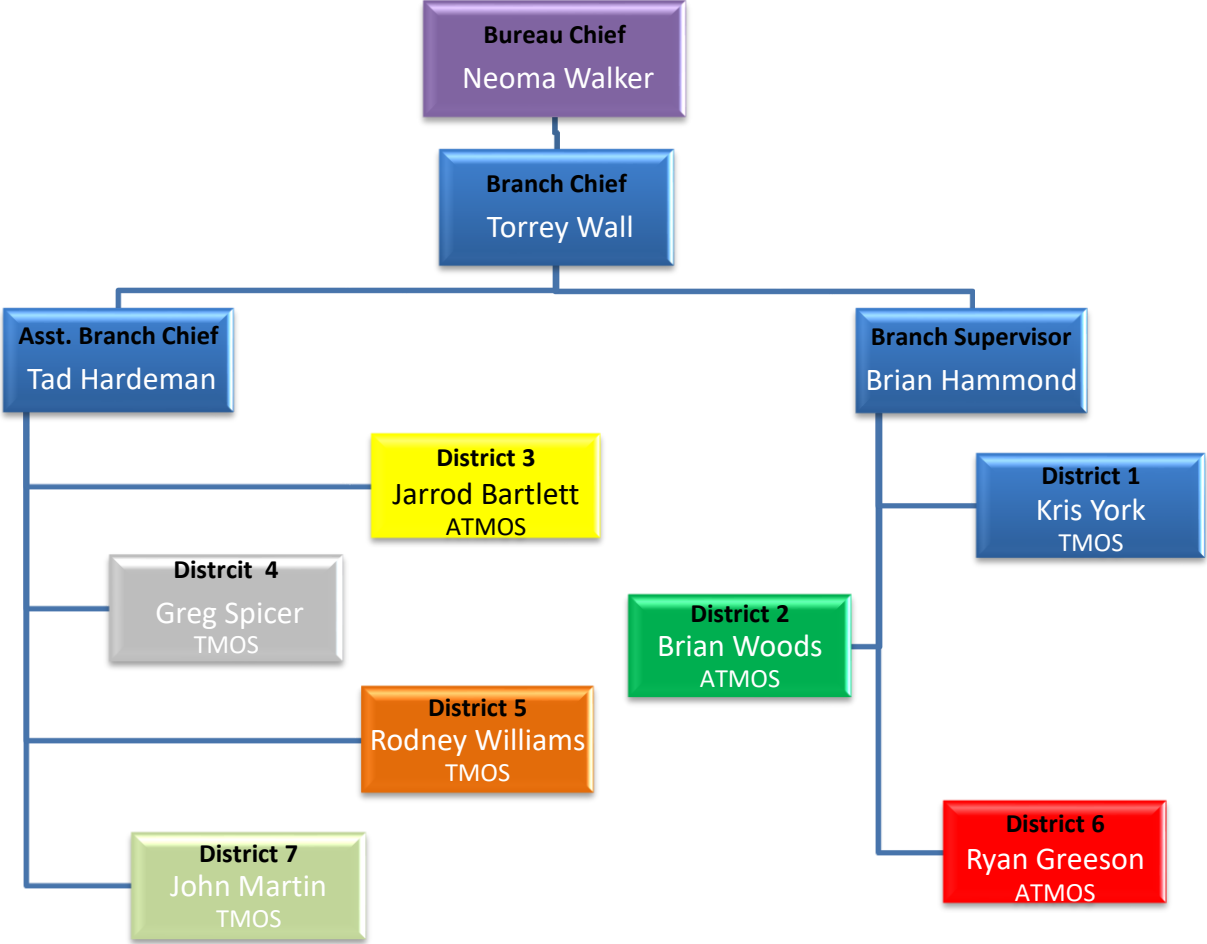

7 Testing Laboratories

Table of Content

Laboratory Soil Testing Technician Certification Study Guide

<u>Page</u>	<u>Titles</u>
4	Introduction
5-8	Program Information
9	Technical Sections
	AASHTO Standards (Test Procedure Not Included)
10-13	R 58-11(2019)
14-18	T 89-13(2021)
19-22	T 90-20
23-25	T265-15(2019)
26-34	T 180-21 Method D
	GDT Standards & Specifications
35-44	GDT 4
47-69	GDT 6
70-107	GDT 7
108-112	Specification Section 810
113-118	Specification Section 814
119-138	Appendix A Answers to Study Questions

INTRODUCTION

I. PURPOSE

The purpose of this study guide is to provide information that is required to learn the necessary procedures and standards established by the Department to become qualified in Preparing and Testing Soils. The Sampling and Testing procedures and Standards Specifications were established to ensure that high quality materials, that meet Specifications, are incorporated into the work. The evidence of testing is an “approved” test report.

The purpose and necessity for evidence of tests completed should be understood by all Contractors, Engineers and Technicians of the Department. It should not be thought that the purpose and only result of testing are test reports. However, this evidence of testing is needed and important, for it is the record of performed tasks. A test report must give complete, clear, and precise results.

It is the Contractor’s responsibility to control the materials and construction in such a manner that the specifications are met. It is the Materials Testing Technician and Engineer’s responsibility to evaluate materials and construction to verify that Specifications are met.

All information included within this guide will aid in the success of Laboratory Testing Technicians becoming proficient performing the essential tasks for Preparing, and Testing Soils used in roadway construction.

GEORGIA DEPARTMENT OF TRANSPORTATION SOIL TESTING TECHNICIAN CERTIFICATION PROGRAM

Definition:

A **Soil Level 1 Testing Technician**— is an individual who has demonstrated the knowledge and ability to properly perform, record, and report the results of basic laboratory procedures for soils.

Scope and Knowledge:

The program requires a working knowledge of the following:

AASHTO/ASTM standards:

- R 58-11(2019)—Standard Practice for Dry Preparation of Disturbed Soil and Soil-Aggregate Samples for Test
- T 89-13(2021)—Standard Method of Test for Determining the Liquid Limit of Soils
- T 90-20— Standard Method of Test for Determining the Plastic Limit and Plasticity Index of Soils
- T 180-21 Method D – Moisture-Density Relations of Soil Using a 10lb Rammer and 18in Drop, utilizing -3/4material in a 6” Mold
- T265-15(2019)—Standard Method of Test for Laboratory Determination of Moisture Content of Soils
- ❖ **Note:** *Due to copyright laws, AASHTO Test Procedures are not provided. AASHTO Procedures may be obtained at <https://compass.astm.org>*
External Companies (Non-GDOT) must provide their employees their own copy of AASHTO Standards due to the copyright laws

GDOT Standards/Specifications:

- GDT 4—Determining Gradation of Soils
- GDT 6—Determining Volume Change of Soils
- GDT 7—Determining Maximum Density of Soils
- Section 810—Roadway Materials
- Section 814—Soil Base Materials

Certification Requirements:

GDOT will grant certification only to those applicants who meet both of the following requirements:

1. A passing grade on the GDOT written examination, and
2. Successful completion of the GDOT performance examination

Written Examination

The written examination is three hours, open-book, and consists of 100 multiple-choice questions. To pass the written examination, both of the following conditions must be met:

1. At least 60% correct for each of the required standards, and
2. A minimum score of 75% overall.

The Technical College System of Georgia will administer the written examination. Examinees will be expected to pay a testing fee when the written portion of the examination is administered.

The campus locations where the written examinations will be administered are as follows.

Technical College Contact Information

College	Name	Number	Email
Albany	Matt Trice	229-430-6618	mtrice@albanytech.edu
Athens	John Usry	706-357-0050	jusry@athenstech.edu
Atlanta	Araceli Flores	404-225-4681	aflores1@atlantatech.edu
Augusta	Laura Giddings	706-771-5705	lgiddings@augustatech.edu
Central Ga	Melanie Bradley	478-2183289	mbradley@centralgatech.edu
Chattahoochee	Tammy Huffstetler	770-975-4041	tammy.hufstetler@chattahoochee.edu
Coastal Pines	Anna McCrea	912-287-5854	amccrea@coastalpines.edu
Columbus	Michelle Shaw	706-649-1558	mshaw@columbustech.edu
GA Northwestern	Patty Hart	706-272-2980	phart@gntc.edu
GA Piedmont	Angela Cooper	404-297-9522, ext.1829	coopera@gptc.edu
Gwinnett	Gwen Moran	678-226-6609	Gmoran@gwinnetttech.edu
Lanier	Joan Lee	770-5336995	jlee2@laniertech.edu
North GA	Leslie Foster	706-754-7715	lfoster@northgatech.edu
Oconee Fall Line	Katrina Veal	478-275-6592	klveal@oflt.edu
Ogeechee	Kristen Waters	912-871-1693	kdwaters@ogeecheetech.edu
Savannah	Lisa Kuyk	912-443-4148	lkuyk@savannahtech.edu
South GA	Tami Blount	229-931-2040	tblount@southgatech.edu
Southeastern	Susan Rustin	912-538-3197	srustin@southeasterntech.edu
Southern Crescent	Steve Hendrix	678-972-9443	shendrix@sctech.edu
Southern Regional (Moultrie campus)	Jena Willis	229-217-4257	jmwillis@southernregional.edu
Southern Regional (Bainbridge campus)	Susanne Reynolds	229-243-3011	sreynolds@southernregional.edu
Southern Regional (Thomasville campus)	Ruby Barron	229-227-2579	rbarron@southernregional.edu
West GA	NO TESTING	n/a	n/a
Wiregrass	Christy Cobb	229-468-2218	Christy.cobb@wiregrass.edu

Performance Examination

The performance examination will be administered by the Georgia Department of Transportation's Office of Materials and Testing staff at the Branch Laboratory associated with each of the Department's Field Districts.

The performance examination is closed-book and requires actual demonstration of the required standards. The examinee is judged on his/her ability to correctly perform or describe all the required procedures for the 8 standards listed. No performance examination is required for specifications Section. The performance examination must be passed within 90 days of passing the written examination.

During the examination the examinee will be judged on their ability to perform or describe all required procedures for each of the AASHTO or GDOT standards based on the criteria in the Performance Examination Checklists. Omission or incorrect performance on one or more of the prescribed procedures will constitute failure of that trial. The examinee will be allowed up to (2) trials on the day of the examination for each GDOT/AASHTO Standard. If during one trial the examinee feels an error has been made, he or she may suspend that trial and begin the procedure over. A voluntary suspension of a trial is not counted as a failure. Failure on any of the prescribed standards after two trials will constitute failure of the performance examination. The performance examination is graded on a pass/fail basis.

Re-Examination

Failure of either the written or performance examination by any of the criteria cited above will require the re-examination on the entire written exam or entire performance exam. It is the examinee's responsibility to request a re-examination.

To protect GDOT's Soil Technician Examinations from frivolous trial-and-error attempts and to encourage the examinee to properly prepare for testing, the following allowances are required.

- After first failed examination, the examinee must wait 30 days before re-testing.
- After second failed examination, the examinee must wait 90 days before re-testing.
- After third failed examination, the examinee must wait 12 months before re-testing.

Recertification

Technicians are not required to have any continuous education credit hours to maintain their Soils Testing Technician Certification after they have successfully passed the written and practical exams and become certified.

Regardless of re-certification status, for the purpose of fulfilling the requirements of SOP 30 as required by the FHWA, active technicians (those who performed acceptance testing in the last calendar year) are required to have an IA evaluation during each calendar year.

**GEORGIA DEPARTMENT OF
TRANSPORTATION SOIL TESTING TECHNICIAN
CERTIFICATION**

WORKBOOK TECHNICAL SECTIONS

Each section consists of:

- GDOT Specification/Standard or AASHTO Standard
- Study Questions
- Performance Checklist, if applicable

SECTION 1

AASHTO R58-11(2019)

Standard Practice for Dry Preparation of
Disturbed Soil and Soil-Aggregate Samples for
Test



STUDY QUESTIONS

AASHTO R 58, Standard Practice for Dry Preparation of Disturbed Soil and Soil-Aggregate Samples for Test

1. This method describes the _____ preparation of soil and soil–aggregate samples?
2. A revolving drum, into which the soil sample and rubber-covered rollers are placed, is a suitable pulverizing device?
 - a) True
 - b) False
3. For the particle size analysis-T88, material passing a 2.00-mm (No. 10) sieve is required in amounts equal to approximately, 110g for _____ soils and approximately 60g for _____ soils.
4. What is the minimum amount required, of material passing the 0.425-mm (No. 40) sieve, for performing physical testing?
5. Samples should be dried at a temperature not exceeding _____?
6. Representative test samples of the amount required to perform the desired tests shall be taken with _____, or by _____ and _____.
7. Samples dried in an oven or other drying apparatus at a temperature not exceeding 60°C [140°F] are air dried?
 - a) True
 - b) False
8. List the two alternate methods used to separate fraction sizes of the portion of the dried sample selected for particle-sized analysis and physical tests?
9. Fractions retained on the 4.75-mm (No. 4) sieve and the 2.00-mm (No. 10) sieve are not included in the sieve analysis and should be discarded?
 - a) True
 - b) False
10. What is the required sample mass of material passing the 2.00-mm (No. 10) sieve, for specific gravity, when the volumetric flask is to be used?
11. Physical tests are performed on materials passing the _____ sieve?

PERFORMANCE CHECKLIST

AASHTO R 58, Standard Practice for Dry Preparation of Disturbed Soil and Soil-Aggregate Samples for Test

Procedure

1. Dry the soil sample thoroughly in air or in the drying apparatus at a temperature not exceeding 60°C [140°F].
2. Obtain a test sample of the required mass to perform the desired tests (Section 4), with a sampler, or by splitting or quartering.
3. Pulverize the samples in such a way as to avoid reducing the natural size of individual particles.
4. Determine the mass of the portion of the dried sample selected for particle-sized analysis and physical tests (including specific gravity).
5. Record mass as the mass of total sample uncorrected for hygroscopic moisture.
6. Separate into fractions by one of the following methods:

Alternate Methods Using 2.00-mm (No. 10) Sieve

7. Separate the dried sample into two fractions using a 2.00-mm (No. 10) sieve.
8. Pulverize the material retained on the sieve until the aggregations of soil particles are broken into separate grains.
9. Re-sieve the ground soil on the 2.00-mm (No. 10) sieve.

Alternate Method Using 4.75-mm and 2.00-mm (Nos. 4 and 10) Sieves

10. Separate the dried sample into two fractions using a 4.75-mm (No. 4) sieve.
11. Pulverize the material retained on the sieve until the aggregations of soil particles are broken into separate grains.
12. Re-sieve the ground soil on the 4.75-mm (No. 4) sieve.
13. Thoroughly mix the fractions passing the 4.75-mm (No. 4) sieve.
14. By use of a sampler, or split and quarter the sample, obtain a representative portion adequate for the desired tests.
15. Separate the dried sample into two fractions using a 2.00-mm (No. 10) sieve.
16. Pulverize the material retained on the sieve until the aggregations of soil particles are broken into separate grains.
17. Re-sieve the ground soil on the 2.00-mm (No. 10) sieve.
18. Record the mass of the material from this split-off fraction that is retained on the 2.00-mm (No. 10) sieve for later use in coarse sieve analysis computations.

Procedure-continued

19. Set aside the fraction retained on the 2.00-mm (No. 10) sieve, or that retained on the 4.75-mm (No. 4) sieve, after the second sieving, for use in sieve analysis of the coarse material.
20. Thoroughly mix the fractions passing the 2.00-mm (No. 10) sieve.
21. By use of a sampler, or split and quarter the sample, obtain representative portions having approximate masses as follows: (1) for the hydrometer analysis and sieve analysis of the fraction passing the 2.00-mm sieve, 110 g for sandy soil and 60 g for silty or clayey soils; and (2) for specific gravity, 25 g when the volumetric flask is to be used and 10 g when the stoppered bottle is to be used.
22. Sieve the remaining portion of the material passing the 2.00-mm (No. 10) sieve over a 0.425-mm (No. 40) sieve.
23. Pulverize the fraction retained on the 0.425-mm (No. 40) sieve in such a manner as to break up the aggregations without fracturing the individual grains.
24. Separate the ground soil into two fractions by means of the 0.425-mm (No. 40) sieve, and regrind the material retained on the sieve.
25. Discard material retained on the 0.425-mm (No. 40) sieve when repeated grinding produces only a small quantity of soil passing the 0.425-mm sieve.
26. Thoroughly mix the several fractions passing the 0.425-mm sieve obtained from the grinding and sieving operations and set aside for use in performing the physical tests.

SECTION 2

AASHTO T 89-13(2021) Standard Method of Test for Determining the Liquid Limit of Soils



STUDY QUESTIONS

AASHTO T 89

Standard Method of Test for Determining the Liquid Limit of Soils

1. The liquid limit of a soil is that _____ at which the soil passes from a plastic to a liquid state.
2. An _____, _____ dish about 115 mm in diameter is preferred for mixing the sample.
3. The liquid limit device shall have a base made of _____ material.
4. List the two types of grooving tools used in this procedure.
5. The flat grooving tool should be used interchangeably with the curved grooving tool?
 - a) True
 - b) False
6. Obtain a sample mass of about _____ g of material passing _____ -mm sieve for method "A".
7. Cup or base wear is considered excessive when the point of contact exceeds _____ in diameter.
8. The height of drop of the cup should be adjusted to _____ and checked _____ prior to testing.
9. What is the initial amount of water to be added to the sample?
 - a) Method "A": _____
 - b) Method "B": _____
10. It is ok to add dry soil material if too much moisture has been added to the sample.
 - a) True
 - b) False
11. A _____ value may be obtained by adding water too fast.
12. What is the maximum thickness allowed when spreading material into the testing cup?
13. How many firm strokes of the grooving tool are allowed to divide the soil in the cup?
14. The cup containing the sample shall be _____ and _____ by turning crank F at a rate of approximately _____ revolutions per second.
15. What steps are taken should the sample slide on the cups surface during test?
16. The _____ and _____ shall be washed and dried between test trials.
17. When performing procedure "A", obtain the first test sample in the range of _____ to _____ shocks.

18. Water content of the soil shall be calculated as follows:

$$\frac{\text{Mass of Water}}{\text{Mass of oven dry Soil}} \times 100$$

- a) True
- b) False

19. The moisture content corresponding to the intersection of the flow curve with the _____-shock ordinate shall be taken as the _____ of the soil.

20. Sample shall be seasoned in the _____ for _____ when performing referee testing.

PERFORMANCE CHECKLIST

AASHTO T 89

Standard Method of Test for Determining the Liquid Limit of

METHOD A

Soils

Procedure

1. Thoroughly mix the portion of material passing the 0.425-mm sieve and obtain a sample with a mass of about 100 g.
2. Thoroughly mix sample with 15 to 20 mL of distilled water by alternately and repeatedly stirring, kneading, and chopping with a spatula.
3. Continue mixing and add further additions of water, in increments of 1 to 3 mL, until the material forms a uniform mass of stiff consistency. Thoroughly mix each increment of water, as previously described in step No. 2, before another increment of water is added.
4. Place enough material in the cup and squeeze and spread, using as few strokes as possible.
5. Level with spatula and, at the same time, trim to a depth of 10 mm at the point of maximum thickness.

Curved Grooving Tool

6. Divide the soil in the cup with a firm stroke of the grooving tool. Up to six strokes, from front to back or back to front, may be used and only the last stroke should scrape the bottom of the cup.

Alternate Procedure (Flat Grooving Tool)

7. Form a groove in the soil pat in accordance with Section 11.2 of ASTM D4318.

Procedure-Continued

8. Lift and drop the cup, at a rate of approximately two revolutions per second, until the two sides of the sample come in contact at the bottom of the groove along a distance of about 13 mm.
9. Record the number of shocks required to close the groove.
10. Remove a slice of soil the width of the spatula, extending from edge to edge of the soil cake at right angles to the groove and including that portion of the groove that flowed together, and place in a suitable container.
11. Dry the sample in accordance with T 265 and determine the moisture content.
12. Transfer the soil remaining in the cup to the mixing dish and wash the cup and grooving tool.
13. Repeat procedure, adding sufficient water to bring the sample to a more fluid condition.
14. Obtain the first sample in the range of 25 to 35 shocks, the second sample in the range of 20 to 30 shocks, and the third sample in the range of 15 to 25 shocks. The range of the three determinations shall be at least 10 shocks.

15. Plot a “flow curve”, on a semilogarithmic graph, representing the relation between moisture content and corresponding number of shocks. The moisture content corresponding to the intersection of the flow curve with the 25-shock ordinate shall be taken as the liquid limit of the soil.

METHOD B

Procedure

16. Thoroughly mix the portion of material passing the 0.425-mm sieve and obtain a sample with a mass of about 50 g.
17. Using the curved grooving tool or the flat grooving tool the procedure shall be the same as prescribed in steps 2 through 12 except that the initial amount of water to be added shall be approximately 8 to 10 mL.
18. Obtain the first sample in the range of 22 to 28 shocks, and immediately return the soil remaining to the mixing dish, without adding additional water, and repeat the test. If the second closure occurs in the acceptable range of 22 to 28 shocks and the second closure is within 2 shocks of the first closure, secure a moisture content specimen.

SECTION 3

AASHTO T 90-20

Standard Method of Test for
Determining the Plastic Limit and Plasticity Index of Soils



STUDY QUESTIONS

AASHTO T 90

Standard Method of Test for

Determining the Plastic Limit and Plasticity Index of Soils

1. The _____ of a soil is the lowest _____ at which the soil remains plastic.
2. The plasticity index is the numerical difference between the _____ and the _____ of the soil.
3. What method shall be used as the referee method?
4. Wax paper would be an acceptable rolling surface?
 - a) True
 - b) False
5. The container used for moisture content shall have a _____ to prevent the loss of moisture from the samples before initial mass determination.
6. If only the plastic limit is determined, what is the initial sample mass, of material passing the 0.425-mm (No. 40) sieve, required for this procedure?
7. Tap water may be used for routine testing?
 - a) True
 - b) False
8. The soil mass should be rolled into a _____ at a rate of _____ per minute.
9. What is the time limit for rolling the soil mass into a thread?
10. When using the alternate procedure, you should not allow the soil thread to contact the _____ of the plastic limit device?
11. It is acceptable for crumbling to occur when the diameter is _____ than 3 mm, provided the solid has been previously rolled into a thread _____ in diameter?
12. Attempts should be made to produce failure at exactly 3-mm by reducing hand pressure?
 - a) True
 - b) False
13. _____ soils require much pressure to deform the thread as they approach the plastic limit?
14. What procedure should be used to determine the moisture content?
15. The plastic limit of the soil is the moisture content expressed as a percentage of the _____?
16. Report the plastic limit to the nearest _____?
17. How is the plasticity index of a soil calculated? _____ - _____ = Plastic Index

PERFORMANCE CHECKLIST

AASHTO T 90

Standard Method of Test for

Determining the Plastic Limit and Plasticity Index of Soils

If Only Plastic Limit is Determined

1. Take a quantity of soil with a mass of about 20 g from the thoroughly mixed portion of the material passing the 0.425-mm (No. 40) sieve.
2. Place test sample in a mixing dish and thoroughly mix with distilled, demineralized, or de-ionized water until the mass becomes plastic enough to be shaped into a ball.
3. Take about 10 g from this ball for the test sample.

If the Plasticity Index (Both Liquid and Plastic Limit) is to be Determined

4. Take a test sample with a mass about 10 g from the thoroughly wet and mixed portion of the soil prepared in accordance with T 89. Take sample at any stage in the mixing process when the mass can be easily shaped into a ball without sticking to fingers.
5. Set aside and allow to season in air until the liquid limit test has been completed.

Procedure

6. Determine and record the mass of the moisture container.
7. Take a 1.5 to 2.0-g portion from the 10-g mass ball of soil.
8. Roll the soil mass into a 3-mm-diameter thread using at a rate of 80 to 90 strokes per minute, counting a stroke as moving the hand forward and back to the starting position.

Hand Rolling Method

9. Roll mass between the palm or fingers and the unglazed paper or glass plate to a uniform diameter throughout its length.
10. Continue to deform the thread until its diameter reaches 3mm.
11. Take no more than 2 minutes to roll the test sample to a 3-mm-diameter.

Procedure Continued

12. When the diameter of the thread reaches 3 mm, form the mass back into an ellipsoidal shape using the thumbs and fingers.
13. Repeat hand rolling operation until the soil can no longer be rolled into a thread and begins to crumble.

14. Gather and place the portions of crumbled soil in moisture content container and cover with a close-fitting lid to prevent moisture loss.
15. Repeat hand rolling operation until the entire 10 g sample is tested.
16. Place all crumbled portions of soil in the same moisture content container.
17. Determine moisture content in accordance with T265.

SECTION 4

AASHTO T265-15(2019)

Standard Method of Test for

Laboratory Determination of Moisture Content of Soils



STUDY QUESTIONS

AASHTO T 265

Standard Method of Test for

Laboratory Determination of Moisture Content of Soils

1. _____ or _____ of a soil is the ratio, expressed as a percentage, of the mass of water in a given mass of soil to the mass of the solid particles?
2. Containers shall have close-fitting lids to prevent _____ from samples before initial weighing and to prevent _____ from the atmosphere following drying and before final weighing.
3. If not indicated in the method of test, what is the minimum sample mass for a soil with a maximum particle size of 12.5-mm (1/2 in.)?
4. Test samples shall be dried in a drying oven maintained at a temperature of _____?
5. Samples should be dried overnight (minimum of _____ hr.) or dry until the mass loss of the sample after 1h of additional drying is less than _____ percent (constant mass)?
6. Dried samples should be removed before placing wet samples in the oven?
 - a) True
 - b) False
7. Oven-drying at $110 \pm 5^\circ\text{C}$ ($230 \pm 9^\circ\text{F}$) does not result in reliable moisture content values for soil containing _____ or other minerals having loosely bound water from _____ or for soil containing significant amounts of _____.
8. When is it acceptable to use a container without a tight-fitting lid?
9. When calculating moisture content, $W_1 =$ _____?
10. What is the single operator precision, acceptable range of two results, when testing a coarse aggregate-blend?

PERFORMANCE CHECKLIST

AASHTO T 265

Standard Method of Test for

Laboratory Determination of Moisture Content of Soils

1. Select a representative quantity of moist soil in the amount indicated in the method of test. If no amount is indicated, the minimum mass of the sample shall be in accordance with the table in T 265.
2. Weigh a clean, dry container with its lid and place the moisture content sample in the container.
3. Immediately place lid on container and weigh the container, including the sample and lid.
4. Remove the lid and place the container with the moist sample in the drying oven.
5. Dry the sample dry overnight (15 h minimum) at a temperature of $110 \pm 5^{\circ}\text{C}$ ($230 \pm 9^{\circ}\text{F}$) or until the mass loss of the sample after 1 h of additional drying is less than 0.1 percent(constant mass).
6. Remove the sample from the oven and immediately place lid on the container.
7. Allow sample to cool to room temperature.
8. Weigh container, including the sample and lid.
9. Calculate the moisture content to the nearest 0.1 percent.

SECTION 5

AASHTO T180 (Method D)

Determining the Moisture-Density Relationship of Soils using a 10lb Rammer
and
18" Drop utilizing -3/4 Material in a 6" Mold



AASHTO T180 Sample Prep (Annex A)

Total Weight (Wet)

****Minimum 11kg Total Dry Mass****

	Accumulated +3/4 (Mmc)	Passing -3/4 (Mmf)	% Retained	% Passing
3/4 " Sieve	<input type="text"/>	<input type="text"/>	#DIV/0!	#DIV/0!

	+ 3/4 (Mcc)	- 3/4 (Mcf)	
Bg Wt	<input type="text"/>	<input type="text"/>	min 500 g
Dry Wt	<input type="text"/>	<input type="text"/>	
% Moist (MC)	0.00	0.00	

	Coarse Dry Mass (Mdc)	**Total Dry Mass**	Fine Dry Mass (Mdf)	
$M_D = M_M / (1 + MC)$	0.0	0.0	0.0	$M_D = M_M / (1 + MC)$

% Coarse Corrected (Pc)

% Fine Corrected (Pf)

$$P_c = 100 M_{DC} / (M_{DF} + M_{DC})$$

$$P_f = 100 M_{DF} / (M_{DF} + M_{DC})$$

T85 Calculation (If not using QPL)

**** Fill in Information in Blue Only**

		1	2	3	4	
AIR	A	<input type="text"/>	A	<input type="text"/>	A	<input type="text"/>
SSD	B	<input type="text"/>	B	<input type="text"/>	B	<input type="text"/>
Water	C	<input type="text"/>	C	<input type="text"/>	C	<input type="text"/>
Gsb		<input type="text"/>	<input type="text"/>	<input type="text"/>	<input type="text"/>	
Gsb(SSD)		<input type="text"/>	<input type="text"/>	<input type="text"/>	<input type="text"/>	
Gse		<input type="text"/>	<input type="text"/>	<input type="text"/>	<input type="text"/>	
% Abs		<input type="text"/>	<input type="text"/>	<input type="text"/>	<input type="text"/>	

Total Sample WT

% of Sample	1	2	3	4
	<input type="text"/>	<input type="text"/>	<input type="text"/>	<input type="text"/>

Avg Gsb

$$Gsb = \frac{A}{B-C} \quad \text{Avg (Gsb)} = \frac{1}{\left(\frac{P1}{100 \times G1}\right) + \left(\frac{P2}{100 \times G2}\right) + \left(\frac{P3}{100 \times G3}\right)}$$

AASHTO T180 Method D Worksheet

10lb Rammer, 18" Drop, -3/4" Material, 6" Mold, 5 Lifts, 56 Blows

	1	2	3	4	5	6	7
Weight of Mold + Sample							
Weight of Mold							
Weight of Sample	0.0	0.0	0.0	0.0	0.0	0.0	0.0
Mold ID #							
GDOT Mold CF							
Calculated Wet Density	0.0	0.0	0.0	0.0	0.0	0.0	0.0
Bowl #	1	2	3	4	5	6	7
Total Weight							
Dry Weight							
Difference	0.0	0.0	0.0	0.0	0.0	0.0	0.0
% Moisture	0.0	0.0	0.0	0.0	0.0	0.0	0.0
Calculated Dry Density	0.0	0.0	0.0	0.0	0.0	0.0	0.0

Maximum Dry Density from Curve (Df)

Optimum Moisture from Curve (MCf)

Gravity (Bulk Specific) Calculated / QPL

% Passing the 3/4 " Sieve (Pf) 0.0

K- Factor Gsb x 62.4 0.0

% Retained on 3/4 " Sieve (Pc) 0.0

% Retained on 3/4 " Sieve (Pc)

% Moisture on the 3/4 " Sieve (MCc) 0.0

% Passing the 3/4 " Sieve (Pf)

Corrected Maximum Dry Density (Dd) **0.0**

Corrected Optimum Moisture (MCt) **0.0**

$$D_d = 100 D_f k / (D_f P_c + k P_f)$$

$$MC_T = (MC_f P_f + MC_c P_c) / 100$$

AASHTO T180 Method D Worksheet

10lb Rammer, 18" Drop, -3/4" Material, 6" Mold, 5 Lifts, 56 Blows

	1	2	3	4	5	6	7
Weight of Mold + Sample							
Weight of Mold							
Weight of Sample	0.0	0.0	0.0	0.0	0.0	0.0	0.0
Mold ID #							
Mold Volume	0.03309						
Calculated Wet Density	0.0	0.0	0.0	0.0	0.0	0.0	0.0
Bowl #	1	2	3	4	5	6	7
Total Weight							
Dry Weight							
Difference	0.0	0.0	0.0	0.0	0.0	0.0	0.0
% Moisture	0.0	0.0	0.0	0.0	0.0	0.0	0.0
Calculated Dry Density	0.0	0.0	0.0	0.0	0.0	0.0	0.0

Maximum Dry Density from Curve (D_f)

Optimum Moisture from Curve (MC_f)

Gravity (Bulk Specific) Calculated / QPL

% Passing the 3/4 " Sieve (P_f) 0.0

K- Factor G_{sb} x 62.4 0.0

% Retained on 3/4 " Sieve (P_c) 0.0

% Retained on 3/4 " Sieve (P_c)

% Moisture on the 3/4 " Sieve (MC_c) 0.0

% Passing the 3/4 " Sieve (P_f)

Corrected Maximum Dry Density (D_d) **0.0**

Corrected Optimum Moisture (MC_t) **0.0**

$$D_d = 100 D_f k / (D_f P_c + k P_f)$$

$$MC_T = (MC_f P_f + MC_c P_c) / 100$$

STUDYQUESTIONS

AASHTO T 180 (Method D)

Moisture-Density Relations of Soils Using 10lb Rammer and an 18" and using material passing the # 3/4 Sieve

1. The mold in this procedure will have an approximate diameter of _____ and height of _____.
2. The metal rammer will have a diameter of _____ and a weight of _____. The rammer will be dropped at a height of _____ from the surface the of the soil.
3. What size sample is taken and dried in a drying apparatus at a temperature not to exceed what temperature?
_____, _____
4. Any material retained on the _____ shall be considered _____.
5. A representative sample of approximately _____ of _____ needed to perform the test.
6. What should the initial moisture content of the sample be mixed to?
7. Each moisture content shall be compacted with _____ blows and in _____ layers?

8. After the mold has been compacted, the collar is removed, and the compacted material trimmed?

- a) at the top of the mold
- b) bottom of the mold
- c) Both top and bottom

9. Calculate the wet weight of the compacted soil in pounds per cubic foot?

Weight of Mold	6595.3 g
Weight of Mold +Sample	11614.5 g
Mold Correction Factor	0.02942
Wet Weight, lbs./ft ³	
Weight of Mold	6595.3 g
Weight of Mold +Sample	11733.8 g
Mold Volume	0.07498
Wet Weight, lbs./ft ³	

10. Samples for determining moisture content are obtained by slicing the compacted soil vertically through its center, and removing _____ or from _____ if the molded material falls apart?

11. Calculate the percent moisture content?

Weight of Wet Soil	1098.8
Weight of Dry Soil	928.6 g
Moisture %	

12. Moisture samples will be dried in an oven capable of maintaining what temperature? _____

13. Moisture will be increased at a rate approximately _____ and the material compacted until _____.

14. The Theoretical Maximum Dry Density and Optimum Moisture will be measured from?

- a) Highest plotted density
- b) the plotted density after decline
- c) Highest moisture content
- d) the peak of the curve

15. Plot the moisture density data points, draw a smooth curve connecting the points?

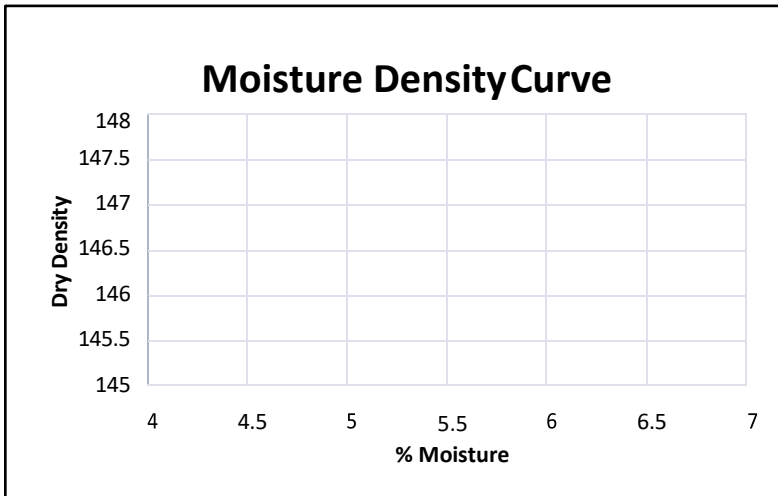

DryDensity	% Moisture
145.5	5.1
146.5	5.3
147.8	5.9
146.4	6.7

Performance Checklist

AASHTO T180 (Method D)

Moisture- density relations of Soils Using a 10lb Rammer and an 18" Drop using material Passing the # ¾ Sieve

1. Obtain a representative sample that weighs a minimum of 25lbs after any material retained on the #3/4 sieve has been removed.
2. Dry the sample in air until friable or by using a drying apparatus that maintains a temperature not exceeding 140F (60C).
3. Break up any aggregations to pass through the 3/4 in (19 mm) sieve without reducing the natural size of the individual particles?
4. Grade over 3/4" sieve and weigh amount retained and set aside for testing outlined in Annex 1?
5. Use R76 to reduce the sample to approximately 25 lbs (11.34 kg)?
6. Thoroughly mix the selected representative sample with enough water to dampen it approximately 4 to 8 percent below optimum moisture?
7. Form a specimen by compacting the prepared material in the 6 in (152.4mm) diameter, 6 in (152.4 mm) high mold (with collar attached)?
8. Lightly tamp the soil prior to compaction until the material is no longer loose or in a fluffy state.
9. Compact the material in five equal layers so the total compacted depth is about 5 in (127 mm)?
10. Compact each layer with 56 uniformly distributed blows from the rammer?

11. After compacting the five layers, remove the collar and carefully trim the compacted material with the straight-edge to be even with the top and bottom of the mold?

12. Weigh the mold and moist material to the nearest 1g.?

13. Calculate and record the wet weight in lbs/ft³ (kg/m³) as follows:
$$\text{Wet weight} = (\text{weight of compacted specimen and mold} - \text{weight of the mold}) \times (13.33).$$

14. Remove the material from the mold by use of a sample extruder and slice it vertically through the center removing the center face of the sample for moisture testing?

15. If the material in the mold is not cohesive take the moisture sample from the center of the pile.?

16. Dry the sample at 230 ° ± 9 °F (110 ° ± 5 °C) in the oven in accordance with AASHTO T 265?

17. Thoroughly break up the remainder of the compacted material until at least 90% of the sample will pass a 3/4 in (19 mm) sieve?

18. Add this material to the original portion of the sample that passed the 3/4 in (19 mm) sieve and was not used before?

19. Add enough water to increase the moisture content of the sample by about 1 to 2 percent?

20. Repeat Procedures, steps 7 through 18. When the test indicates there is either a decrease or no change in the wet weight/ft³ (m³) of the compacted material perform one additional test to assure there is a minimum of two determinations below optimum.

SECTION 6

GDT 4

Determining Gradation of Soils



GDT

4

A. Scope

For a complete list of GDTs, refer to the STI (Sampling, Testing and Inspection) section of “The Source”, which is the Georgia Department of Transportation’s online reference for contractors.

Use this test method to quantitatively determine particle size in soils, soil aggregate, graded aggregate, and similar roadway materials.

B. Apparatus

The apparatus consists of the following:

1. Oven: A thermostatically controlled drying oven capable of maintaining temperatures of 230 ± 9 °F (110 ± 5 °C) for drying the sieve analysis samples.
2. Balance: The balance shall have sufficient capacity, be readable to 0.1 percent of the sample mass, or better, and conform to the requirement of AASHTO M231.
3. Sieves: A series of sieves consisting of the #40, #60 and #200, constructed with a square mesh woven cloth, conforming to the requirements of ASTM E11.
4. Mechanical Sieve Shaker—A mechanical sieving device, if used, shall create motion of the sieves to cause the particles to bounce, tumble, or otherwise turn so as to present different orientations to the sieving surface. The sieving action shall be such that the criterion for adequacy of sieving described in Section D, Step No. 23, is met in a reasonable time period.
5. Large Pan: Suitable large pan made of material resistance to corrosion and subject to change in mass or disintegration from repeated use or other suitable device such as a large cloth.
6. Scoop: Suitable device for mixing and sampling the material.
7. Sample Splitter—A suitable riffle sampler or sample splitter for proportional splitting of the sample and capable of obtaining representative portions of the sample without appreciable loss of fines. The width of the container used to feed the riffle sample splitter should be equal to the total combined width of the riffle chutes. Proportional splitting of the sample on a canvas cloth is also permitted.
Note—The procedure for proportional splitting is described in R 76.
8. Storage Cups: Use pint-sized (0.473 L) cups or other suitable containers identified numerically for storing a sample of the material.
9. Funnel: Use a funnel with at least a 3 in (75 mm) intake diameter and at least a 1/2 in outlet diameter to put soil into bottles without spilling.
10. Bottles: a or b
 - a. Use 8 oz (237 ml), wide-mouth bottles, approximately 1.3 in (33 mm) inside mouth diameter, 5.35 in (136 mm) high, and 4 in (102 mm) from the bottom to the bottom of the neck. This bottle requires a siphoning wand that has a reach of 3.5 in (89 mm) from the top of the bottle with a clearance from the bottom of the wand to the bottom of the bottle of $1.625 \pm 1/16$ in ($41.3 \text{ mm} \pm 1.6 \text{ mm}$). The bottles must be clear and free from chips.
 - b. Use 8 oz (237 ml), wide-mouth bottles, approximately 1.2 in (30 mm) inside mouth diameter, 5.5 in (140 mm) high, and 4 in (102 mm) from the bottom to the bottom of the neck. This bottle requires a siphoning wand that has a reach of 3.7 in (94 mm) from the top of the bottle with a clearance from the bottom of the wand to bottom of the bottle $1.625 \pm 1/16$ in ($41.3 \text{ mm} \pm 1.6 \text{ mm}$). The bottles must be clear and free from chips.
11. Sodium Hexametaphosphate Solution: Use a mixture of 5 gal (19 L) potable water, and 10 oz (285 g) of Sodium Hexametaphosphate.
12. Timing Device: A watch or clock readable to the nearest second.
13. Evaporation Dishes: Use dishes to evaporate the water from the minus No. 10 (2.00 mm) sample.
14. Water Changing Assembly: Use a reversible-fill siphon assembly for changing the water in the bottle. The device shall consist of 1/4 in (6 mm) copper or stainless steel tubing of such length that when placed into the bottle, the end reaches $1.625 \pm 1/16$ in ($41.3 \text{ mm} \pm 1.6 \text{ mm}$) from bottom of the bottle. The water supply should have an aspirator for the fill/empty cycle.

15. Bottle Flushing Assembly: Use a 3/16 in (4 to 6 mm) copper tube bent into an ogee shape and preferably mounted stationary on a working platform at eye level. The outlet end of the tube should be pointed up, and the middle of the tube should be oriented such that an evaporating dish will fit under it.
Optional: The copper or stainless steel tube may be hand-held provided all the material is washed into the dish and the dish does not overflow.
16. Bottle: Use a 5 gal (19 L) aspirator bottle.
17. tiring Device: Any nonporous device suitable for stirring the sample mixture without loss of material.

C. Sample Size and Preparation

1. Prepare the sample received from the field in accordance with AASHTO R 58, Standard Practice for Dry Preparation of Disturbed Soil and Soil-Aggregate Samples for Test.
2. Separate the materials retained on the No. 10 (2.00 mm) sieve into a series of sizes 3 in., 2 in., 1 in., 3/8in., and the No. 4 (75, 50, 25, 9.5 and 4.75-mm) sieves and using other sieves as may be needed depending on the sample or on the specification for the material being testing.
3. Weigh and record the cumulative weights retained, for the coarse (plus No. 10) materials, in accordance with AASHTO T-27, Standard Method of Test for Sieve Analysis of Fine and Coarse Aggregate.
4. Transfer the portion of material passing the No. 10 (2.00 mm) sieve, obtained from the portion of the sample selected for particle analysis in step No. 1, into a large pan or onto a suitable cloth and mix it thoroughly.
5. Using a sampler, or by splitting or quartering, obtain representative portions, from the thoroughly mixed materials prepared in step No. 4, having the following masses: (1) for GDT 6 – volume change of soils, 1000 +/- 1g; (2) for GDT 7 – maximum dry density and optimum moisture, 3000g; and (3) for grading the minus No. 10 (2.00 mm) material by elutriation, a pint-sized storagecup.

D. Procedures

Grading the Minus No. 10 (2.00 mm) Material by elutriation.

Grade the minus No. 10 (2.00 mm) material by elutriation when the governing Standard Specifications call for GDT-4. The process is:

1. Using a sampler, or by splitting or quartering, obtain two 50g samples from the material in the pint-sized storage cup.
2. Place one sample in an evaporating dish.
3. Dry the sample to a constant mass at a temperature of 230 ± 9 °F (110 ± 5 °C).
4. Weigh the sample and determine its mass to the nearest 0.1g. Record this mass as Sample No. 1. Use this value as the original dry weight to calculate the grading of the minus No. 10 (2.00 mm) material.
5. Fill a test bottle to approximately 2 in. (50mm) of sodium hexametaphosphate solution.
6. Use the funnel to place the second sample into the test bottle containing hexametaphosphate solution.
7. Bump the funnel a few times to ensure that the fines clinging to the surface fall into the test bottle.
8. Vigorously stir the soil with a suitable nonporous stirring device(e.g.) to reduce the cohesive forces of the clay.
9. Allow the test bottle, containing sodium hexametaphosphate solution and soil, to stand for a minimum of 10minutes.
10. Using the water change assembly, add water to the test bottle in a manner that will vigorously agitate the material. Continue to add water, using the agitating action, until the test bottle is filled to the height where the bottleneck begins.
11. Allow the test bottle, water, and sample to stand undisturbed for 8 to 10minutes.
12. Using the water change assembly, siphon off the fluid level to about 3/4 in. (18mm) above the soil.
13. Using the water change assembly, refill the test bottle in a manner that will vigorously agitate the material. Continue to add water, using the agitating action, until the test bottle is filled to the height where the bottleneck begins.
14. Allow the test bottle, water, and sample to stand undisturbed for 8 to 10minutes.
15. Repeat steps No. 10 through No. 14 until the fluid above the sample becomes clear enough, after step No. 14, to read a watch on the opposite side of the test bottle.
16. Using the water change assembly, siphon off the water and transfer the soil and remaining water from the test bottle into an evaporating dish.
17. Flush the inside of the test bottle clean with two or three short spurts of water from the bottle flushing assembly into the

evaporating dish. Be careful not to lose any portion of the sample.

18. Allow the sample to stand in the evaporating dish until the liquid clears.
19. Decant excess water with care not to lose any of the finematerial.
20. Dry the material to constant mass at a temperature of $230 \pm 9^{\circ}\text{F}$ ($110 \pm 5^{\circ}\text{C}$).
21. Weigh the sample and determine its mass to the nearest 0.1g. Record this mass as Sample No.2.

22. Sieve the dry sample over a nest of sieves, the No. 40, No. 60, and No. 200, arranged in order of decreasing size from top to bottom.
23. Continue sieving for a sufficient period and in such manner that, after completion, not more than 0.5 percent by mass of the sample No. 2, as determined in step No. 21, passes any sieve during 1 min of continuous hand sieving performed as follows: Hold the individual sieve, provided with a snug-fitting pan and cover, in a slightly inclined position in one hand. Strike the side of the sieve sharply and with an upward motion against the heel of the other hand at the rate of about 150 times per minute, turn the sieve about one sixth of a revolution at intervals of about 25 strokes.
24. Determine the mass of each size increment to the nearest 0.1g.
25. The total mass of the material after sieving shouldn't differ by more than 0.3 percent of the total original dry mass of the sample placed on the sieves, sample No. 2. If the two amounts differ by more than 0.3 percent, based on the total original dry sample mass, the results should not be used for acceptance purposes.
26. Calculate percentages passing, total percentages retained, and clay percentage to the nearest 0.1 percent on the basis of the total mass of Sample No. 1, determined in step No. 4. These test results shall be used to classify soils, as established in GDOT Standard Specifications, Section 810-Materials, Table 1.
27. When required, compute the sieve analysis and clay percentage, of materials passing the No. 10 (2.00 mm) sieve, to represent the total sample as determined in Section E., Step No. 2 and Step No. 4.

E. Calculations

1. Retained (percent) = $100 (B \div A)$

Passing (percent) = $100 (A - B) \div A$

Check: percent retained + percent passing = 100.0 percent

Where:

A = the total sample weight if the sieve is No. 10 (2.00 mm) or larger, or

A = the weight of the 50.0 g sample (Sample No. 1) after it was dried to a constant weight if the sieve is smaller than the No. 10 (2.00 mm)

B = cumulative weight retained on the specific sieve

Adjust the gradation of the minus No. 10 (2.00 mm) portion to represent the total sample as follows:

C = $D \times E \div 100$ where:

C = percent of the total sample smaller than the specific sieve

D = percent passing the No. 10 (2.00 mm) sieve

E = percent of the minus No. 10 (2.00 mm) portion that passed the specific sieve

Examples of Calculations:

Total Sample Weight = 28,650 g			
Gradation of Plus No. 10 (2.00 mm)			
Sieve	Accumulative Weight Retained	Percent of Total Sample	
		Retained	Passing
1-1/2 (37.5 mm)	0	0	100.0
3/4 (19.0 mm)	5,850	20.4	79.6
10 (2.0 mm)	17,450	60.9	39.1

Accumulative percent retained on and passing the 3/4 in (19.0 mm) sieve:

Retained on 3/4 in (19.0 mm) sieve = $100 (B \div A)$

= $100 (5,850 \div 28,650) = 100 (0.204)$

= 20.4 percent retained

Passing 3/4 in (19.0 mm) sieve = $100 (A - B) \div A$

= $100 (28,650 - 5,850) \div 28,650$

$$= 100 (0.796) = 79.6 \text{ percent passing}$$

$$\text{Check: percent retained} + \text{percent passing} = 100.0 \text{ percent}$$

$$20.4 \text{ percent} + 79.6 \text{ percent} = 100.0 \text{ percent}$$

Gradation of Minus No. 10 (2.00 mm)				
Weight of 50 g sample after drying = 49.1 g				Adjusted for Total Sample Percent Passing
Sieve	Accumulative Weight Retained	Retained	Passing	
40 (425 μm)	19.5	39.7	60.3	23.6
60 (250 μm)	27.1	55.2	44.8	17.5
200 (75 μm)	40.0	81.5	18.5	7.2
Total	44.1	89.8		
Clay (effluent) =			10.2	4.0

$$\text{Retained on No. 60 (250 } \mu\text{m)} = 100 (B \div A)$$

$$= 100 (27.1 \div 49.1)$$

$$= 100 (0.552)$$

$$= 55.2 \text{ percent retained}$$

$$\text{Passing No. 60 (250 } \mu\text{m)} = 100 (A - B) \div A$$

$$= 100 (49.1 - 27.1) \div 49.1$$

$$= 100 (22.0) \div 49.1 = 44.8 \text{ percent passing}$$

$$\text{Minus No. 60 (250 } \mu\text{m) in total sample} = (D \times E) \div 100$$

$$= (39.1 \times 44.8) \div 100$$

$$= 1751.68 \div 100$$

$$= 17.5 \text{ percent}$$

Clay is the material washed from the 50 g sample; therefore, it is not in the washed sample.

$$\text{Clay (percent) in minus No. 10 (2.00 mm)}$$

$$= 100 (A - B) \div A$$

$$= 100 (49.1 - 44.1) \div 49.1 = 100 (0.102)$$

$$= 10.2 \text{ percent}$$

$$4. \text{ Clay (percent) in total sample} = (D \times E) \div 100$$

$$= (39.1 \times 10.2) \div 100$$

$$= 3.988 \text{ or } 4.0 \text{ percent}$$

F. Report

1. Report the percent passing each sieve to the nearest 0.1 percent.
2. Report the percent clay to the nearest 0.1 percent.

TUDY QUESTIONS

GDT 4

Determining Gradation of Soils

1. Glass bottles used for this procedure must be _____ and free of _____?
2. A Sodium Hexametaphosphate solution mixture of _____ potable water, and _____ of Sodium Hexametaphosphate is needed for this procedure?
3. A _____ siphon assembly is used for changing the water in the bottle?
4. Initial drying of the sample shall be performed at a temperature not exceeding _____?
5. If coarse material is present, what test procedure is used to grade the aggregates?
6. Samples for density, and volume change are taken from materials that pass the _____ sieve?

Procedure

7. How many samples of material passing the No. 10 (2.00 mm) sieve are weighed out for grading and what are their individual masses?
8. The sample used for determining the original dry weight, for calculating the grading of the minus No. 10 (2.00 mm) material, should be dried _____ to a _____?
9. How much sodium hexametaphosphate solution should be in the test bottle when initially adding the test sample?
10. The sample in the test bottle should be _____ with a _____ to reduce the cohesive forces of the clay.
11. How long should the test sample and hexametaphosphate solution be allowed to stand before adding water?
12. After filling the test bottle with water, the test bottle should be allowed to stand _____ for _____ to _____ minutes before the water is siphoned off?
13. Fluid should be siphoned off until it is about _____ above the soil?
14. The refilling and siphoning process should continue until the fluid above the sample becomes clear enough to read a _____ on the _____ of the bottle.

15. Washed samples should be dried to a constant mass at a temperature of _____?

16. When calculating the percent passing a sieve smaller than the No. 10 (2.00 mm), A = the weight of the 50.0 g sample after it was dried to a constant weight?

- a) True
- b) False

17. Calculate percent passing and adjusted for total percent passing:

Total Sample Weight = 28,000g			
Gradation of Plus No. 10 (2.00 mm)			
Sieve	Accumulative Weight Retained	Percent of Total Sample	
		Retained	Passing
1-1/2 (37.5 mm)	0	0	100.0
3/4 (19.0 mm)	5,000		

Gradation of Minus No. 10 (2.00 mm)				
Weight of 50 g sample after drying = 49.5g				Adjusted for Total Sample Percent Passing
Sieve	Accumulative Weight Retained	Retained	Passing	
40 (425 µm)	16.3			
60 (250 µm)	26.5			
200 (75 µm)	39.8			
Clay (effluent) =				

PERFORMANCE CHECKLIST

GDT 4

Determining Gradation of Soils

1. Prepare the sample received from the field in accordance with AASHTOR-58.
2. Perform sieve analysis, on materials retained on the 2.00-mm (No. 10) sieve, in accordance with AASHTO T-27, Standard Method of Test for Sieve Analysis of Fine and Coarse Aggregate.
3. Use 3 in., 2 in., 1 in., 3/8in., and the No. 4 (75, 50, 25, 9.5 and 4.75-mm) sieves, other sieves may be needed depending on the sample or the specification for the material being tested.
4. Transfer the material passing the 2.00-mm (No. 10) sieve into a large pan or onto a suitable cloth and mix it thoroughly.
5. Using a sampler, or by splitting or quartering, obtain representative portions having approximate masses as follows: (1) for GDT 6 – volume change of soils, 1000 +/- 1g; (2) for GDT 7 – maximum dry density and optimum moisture, 3000g; and (3) for physical tests, a pint-sized storage cup.

Procedure - Grading the minus No. 10 material

6. Using a sampler, or by splitting or quartering, obtain two 50g samples from the material in the pint-sized storage cup that was retained for physical testing.
7. Place one sample into an evaporating dish and dry to a constant weight at a temperature of $230^{\circ} \pm 9^{\circ}\text{F}$ ($110^{\circ} \pm 5^{\circ}\text{C}$).
8. Remove sample from the oven and allow to cool to room temperature.
9. Record sample mass as the original dry mass to calculate the grading of the minus No. 10 (2.00 mm) sieve.
10. Fill test bottle, to approximately 2 in. (50mm), of sodium hexametaphosphate solution.
11. Place remaining 50g sample into test bottle and vigorously stir with a glass rod.
12. Allow the test bottle, containing sodium hexametaphosphate solution and soil, to stand undisturbed for a minimum of 10minutes.
13. Use water changing assembly to add water to the test bottle, in a manner that will vigorously agitate the material, to the height where the bottle-neck begins.

14. Allow the test bottle, containing sodium hexametaphosphate solution, water, and soil, to stand undisturbed for a minimum for 8 to 10 minutes.
15. Use water changing assembly to siphon off the fluid to approximately 3/4 in (18 mm) above the sample.
16. Using the water change assembly, refill the test bottle in a manner that will vigorously agitate the material. Continue to add water, using the agitating action, until the test bottle is filled to the height where the bottle neck begins.
17. Repeat steps 13 through 16 until the fluid above the sample becomes clear enough, after step 16, to read a watch on the opposite side of the bottle.
18. Transfer the test sample to an evaporating dish.
19. Dry the test sample to a constant mass at a temperature of $230^{\circ} \pm 9^{\circ}\text{F}$ ($110^{\circ} \pm 5^{\circ}\text{C}$).
20. Remove test sample from oven and allow to cool to room temperature.
21. Sieve the dry sample over the No. 40, No. 60, and No. 200 sieves.
22. Report the percent passing each sieve, and the percent clay, to the nearest 0.1 percent.

SECTION 7

GDT 6

Determining Volume Change of Soil



A. Scope

This method describes the procedure used to determine the volume change of soil caused by the absorption and loss of water.

B. Apparatus

The apparatus consists of the following:

1. Swell Mold—A cylindrical metal mold approximately four $4 \pm .02$ in (100 ± 0.51 mm) inside diameter and $1 \pm .01$ in (2.5 ± 0.13 mm) high. Each mold is fitted with a detachable perforated base plate and a removable extension approximately 2 in (50.8 mm) high. (See [Figure 1](#))(WM-08).
2. Shrinkage Mold—The same mold as the swell mold except it requires close tolerances. The height at any point is $1 \pm .005$ in (25 ± 0.13 mm) and diameter at any point is $4 \pm .01$ in (100 ± 0.25 mm). Paint the shrinkage mold a different color to distinguish it from the swell molds(WM-08).
3. Rammer—A metal rammer having a 2 in (50mm) diameter flat circular face and weighing 5.5 lbs. (2.49 kg). Has a controlled height of free-fall of $12 \frac{1}{8}$ in ± 0.06 (303 ± 1.5 mm) (WR-1). When using a mechanical rammer, observe the following:
 - a. After use each day, oil the shaft with a thin lubricant.
 - b. Before use each day, wipe clean the shaft and allow to drop 25 times to standardize the shaft friction.
 - c. Check the mechanical rammer for tolerances semi-annually using the procedures in AASHTO T-99.
4. Water Vat—A pan at least $1\frac{1}{2}$ in (38 mm) deep with a bottom flat enough that the water surface strikes the same point within $\frac{1}{16}$ in (1.6 mm) on all mold assemblies in the vat. Place a screen wire or similar object in the vat to ensure that water can get under the molds.
5. Drying Rack—A flat perforated metal plate with five $\frac{3}{8}$ in (10 mm) diameter holes located symmetrically under each specimen used to dry and cool shrinkage specimen.
6. Absorbent Papers—Absorbent paper used in the swell test. Two types of absorbent paper are used: a Number 1 qualitative 4 in (100 mm) diameter paper placed in the bottom of the mold, and a double thickness paper towel measuring about $4\frac{1}{2}$ in (114 mm) square is wet and placed on top of the specimen after the water level has been adjusted (WP-03-1).
7. Extruder—A cylindrical device 3.90 TO 3.97 in (99.1 to 100.8 mm) diameter used to remove the compacted shrinkage specimen from the mold(W-9).
8. Scales—A balance or scale having a capacity in excess of 2.2 lbs. (1000 g), sensitive to 0.0022 lbs (1.0 g). (WB-ELC-1).
9. Drying Oven—An oven with the temperature thermostatically controlled to 230 ± 9 °F (110 ± 5 °C) used to dry the shrinkage specimen.
10. Knife—A stiff sharp blade approximately 12 in (300 mm) long with the cutting edge straight to within $\frac{1}{32}$ in (0.8 mm) throughout its length. Used for slicing the compacted specimen flush with the top of the mold-(WS-13-1).
11. Swell Thickness Measuring Device—Device consisting of a one 1 in (25.4 mm) travel micrometer dial readable to and sensitive to one-thousandth 0.001 in (0.025 mm) and the stand shown in [Figure 2](#). Measure the original and final thickness with this device by lowering the foot gently until contact is made with the surface of the specimen. Exercise caution to avoid penetration.
12. Shrinkage Thickness Measuring Device—A one 1 in (25.4 mm) travel micrometer dial readable to and sensitive to 0.001 in (0.025 mm). Use the stand shown in [Figure 3](#) to measure the original and final thickness of the shrinkage specimen.
13. Shrinkage Final Diameter Measuring Device—A device consisting of a 1 in (25.4 mm) travel micrometer dial readable to and sensitive to 0.001 in (0.025 mm) and the stand shown in [Figure 4](#). The original diameter is $4 \pm .005$ in (101.6 ± 0.13 mm) as given in [step 2](#) above.
14. Calibration Tool—A calibration tool used to adjust each of the 3 measuring devices to read “zero” at a point that will allow gauge travel over the range of anticipated measurements. The constants, 6.35, 22.23, and 82.55, shown in

[Figure 5](#) are added to the shrinkage thickness, swell thickness, and shrinkage diameter dial readings respectively to produce the measurements of the specimen. All swell base plates are preadjusted to give a dial reading of zero (WG-8).

15. Plastic Bags — Bags with a 2 qt (2 L) capacity (WB-01).
16. Graduated Cylinders—A 3.4 oz (100 ml) graduate cylinder(Bit-04-100).

C. Sample Size and Preparation

No sample preparation is needed.

D. Procedures

1. Take a 2.2 +0.0022 lbs (1000 + 1.0 g) sample of the minus No. 10 (2.00 mm) material from the material obtained according to GDT 4, “Method of Test for Determining Gradation of Soils.”
2. Place the sample in a plastic bag and thoroughly mix it with enough water to bring the moisture content to optimum as determined by GDT 7, “Method of Test for Determining Maximum Density of Soils” or by GDT 67. After mixing, seal the sample in a plastic bag for a minimum of 1 hour.
3. Swell Testing—Place a 4 in (100 mm) diameter absorbent paper in the assembled swell mold with the extension intact and placed under the rammer. Put half of the wet material into the mold and lower the rammer to touch the soil. Compact the material with 25 freefalls with the rammer.

Remove the extension and carefully slice the surface of the specimen flush with the top of the mold. Separate the mold full of soil from the base plate with a twisting motion and remove from the base plate, invert, and replace on the absorbent paper and perforated base plate. (Use two different base plates to avoid excessive wing nut adjusting.) Ensure that each base plate for the swell test has the dial plate support preadjusted so the micrometer dial reads zero on the 0.875 in (22.22 mm) constant of the calibration tool when arranged as shown in [Figure 2](#) with the mold removed. Using the measuring device in [Figure 2](#), determine and record the original swell thickness reading.

Place the assembled mold, base plate, and sample into the empty vat. After all the swell samples are in the vat, slowly put water into the vat until the water level is at the top of the mold side pin, but not covering it. Wet and place an absorbent paper measuring about 4½ in (114 mm) square on top of each swell specimen so each corner will drop into the water. After the specimen has remained in the vat undisturbed for 20 1/2 hours, carefully remove the paper and make and record a final thickness measurement. Since the specimen diameter is constant, the only change is in thickness; therefore, the percent swell is calculated as follows:

$$\text{Swell \%} = 100 * \left[\frac{\text{Final Dial Reading} - \text{Original Dial Reading}}{\text{Original Dial Reading} + 0.875} \right]$$

4. Shrinkage Testing—Place the other half of the wet material in [step 2](#) into the assembled mold, base plate, and extension and put under the rammer. Lower the rammer to touch the soil and apply 25 tamps to compact the material. Remove the extension and carefully splice flush the surface of the specimen with the top of the mold. Separate the mold full of soil from the base plate with a twisting motion and remove from the base plate. Place the mold full of soil on the extruder and carefully push the mold from around the specimen. Carefully place the specimen on the measuring stand in [Figure 3](#) and record the original thickness dial reading. Place the specimen on the drying rack and allow it to air dry for about 1 hour after compacting and measuring all specimens to be tested.

Place the rack of specimen in the oven for 20 1/2 hours. Remove the rack of samples from the oven and allow to cool for about 30 minutes. Determine the final thickness dial reading and final diameter dial reading using the devices in [Figure 3](#) and [Figure 4](#), respectively. In determining the final diameter dial reading, the circular end of the specimen faces the same direction as the dial to ensure proper centering of the specimen. Record the thickness dial reading and the mean diameter dial reading. Calculate the percent of shrinkage as follows:

$$\text{Shrinkage \%} = \frac{\text{Original Volume} - \text{Final Volume}}{\text{Original Volume}}$$

Original Volume, in³ = 0.7854 (4in)² (.250 in + B) [mm³ = 0.784 (101.6 mm)² (6.35 mm + B)]

Final Volume, in³ = 0.7854 (3.250 in + FD)² (.250 in + FD) [mm³ = 0.7854 (82.55 mm + FD)² (6.35 mm + FT)]

Where:

B = beginning dial reading for thickness FT = final

dial reading for thickness

FD = final dial reading for diameter

If desired, the following simplified formula may be used:

$$\% \text{ shrinkage} = 100 \frac{(3.250 + FD)^2 (250 + FT)}{.16(250 + B)}$$

5. Correction for Plus No. 10 (2.00 mm) Material—Where the soil contains particles larger than the No. 10 (2.00 mm) sieve, the swell and shrinkage shall be corrected to reflect the percentage of Plus No. 10 (2.00 mm) material if the applicable specifications require volume change results on the total sample. Conversion factors for correcting the swell and shrinkage are given in the [Volume Change Conversion Tables](#).
6. Total Volume Change—Calculate the total percentage points of volume change with the formula: Total Volume Change = Percent Swell + Percent Shrinkage

E. Calculations

No calculations are needed.

F. Report

Report swell, shrinkage, and volume change to the nearest 0.0022 lb (1.0 g) for minus No. 10 (2.00 mm) or total sample, whichever is appropriate.

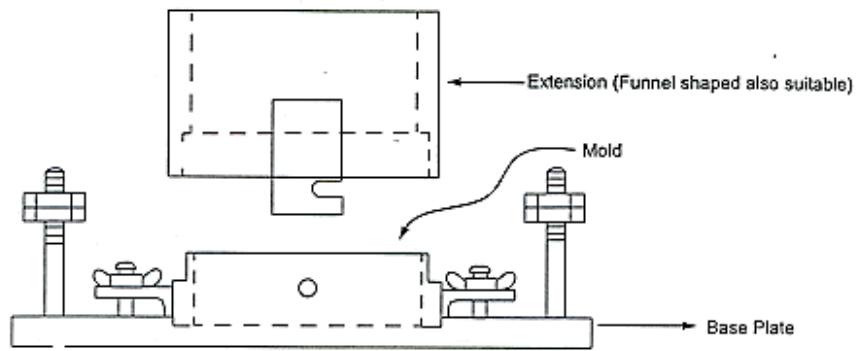

Assembled Mold, Base Plate, and Collar

Figure 1

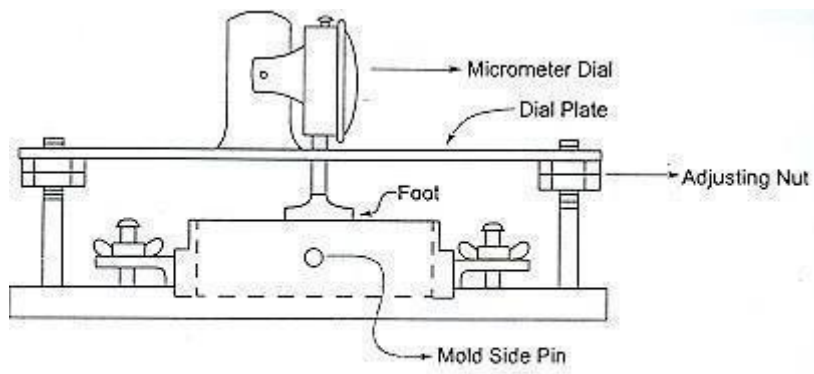

Figure 2
Swell Thickness

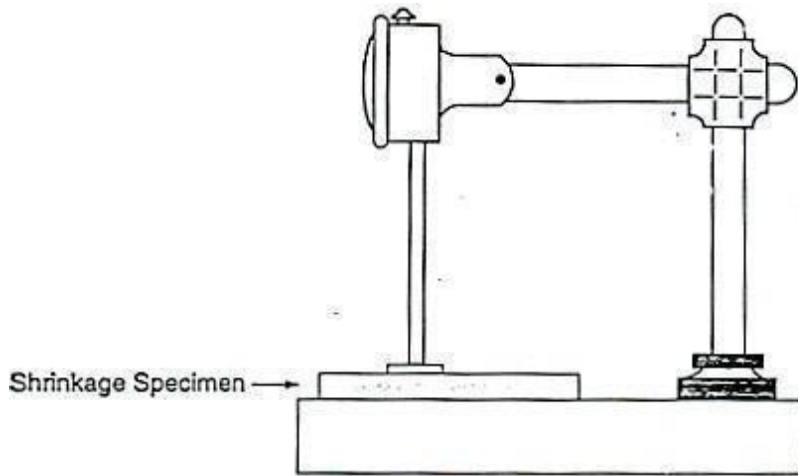

Figure 3
Shrinkage Thickness

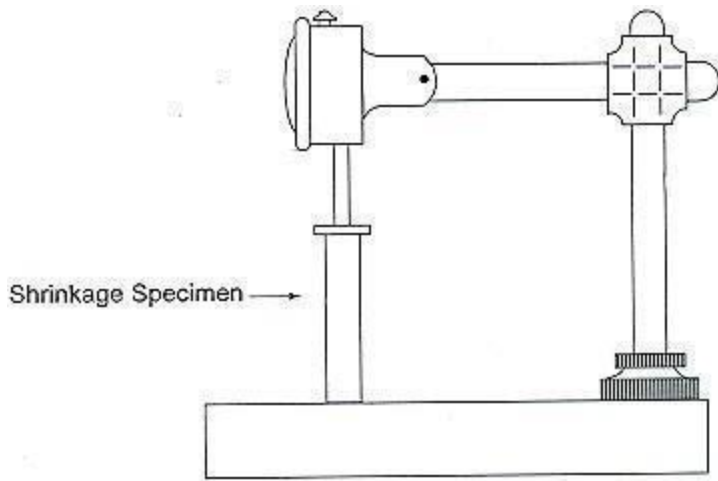
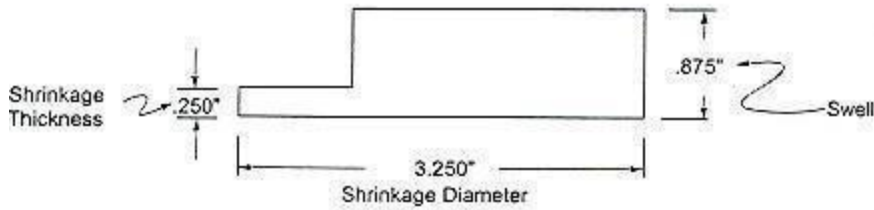

Figure 4
Shrinkage Final Diameter

Figure 5

Calibrating Tool



Volume Change Conversion Tables

This table on the next 12 pages gives a conversion factor for the related volume change of plus and minus No. 10 materials combined to the minus No. 10 material volume change.

Example Of Application:

Suppose a soil sample has 25 percent plus No 10 material. The minus No. 10 material has a proctor density of 100 pounds per cubic foot and a shrinkage of 12 percent. To determine the composite soil (plus the minus No. 10 material) shrinkage, locate the 100 line in the left hand column, then follow this line right to the 25 percent column. The factor given is 0.804. Thus $12 \times .804 = 9.6$ percent shrinkage for the composite soil.

GDT-6: Volume Change Conversion Tables

Density	% Retained					
	1-10	11-20	21-30	31-40	41-50	51-60
80-105	6-1A	6-1C	6-1E	6-1G	6-1I	6-1K
106-130	6-1B	6-1D	6-1F	6-1H	6-1J	6-1L

6-1A	% Retained on No. 10 Sieve									
Density	1	2	3	4	5	6	7	8	9	10
80	.994	.989	.983	.978	.972	.965	.959	.953	.946	.939
81	.994	.989	.983	.978	.972	.965	.958	.952	.945	.938
82	.994	.988	.983	.977	.971	.964	.958	.952	.945	.938
83	.994	.988	.983	.977	.971	.964	.957	.951	.944	.937
84	.994	.988	.982	.976	.970	.963	.957	.951	.944	.937
85	.994	.988	.982	.976	.970	.963	.956	.950	.943	.936
86	.994	.988	.982	.976	.970	.963	.956	.949	.942	.935
87	.994	.988	.981	.975	.969	.962	.955	.948	.941	.935
88	.994	.988	.981	.975	.969	.962	.955	.948	.941	.934
89	.994	.987	.981	.974	.968	.961	.954	.947	.940	.933
90	.994	.987	.981	.974	.968	.961	.954	.946	.939	.932
91	.994	.987	.981	.974	.968	.960	.953	.945	.938	.931
92	.993	.987	.980	.974	.967	.960	.953	.945	.938	.930
93	.993	.987	.980	.974	.967	.959	.952	.944	.937	.930

94	.993	.986	.980	.973	.966	.959	.952	.944	.937	.929
95	.993	.986	.980	.973	.966	.958	.951	.943	.936	.928
96	.993	.986	.980	.973	.966	.958	.951	.942	.935	.927
97	.993	.986	.980	.973	.966	.958	.950	.942	.934	.926
98	.993	.986	.979	.972	.965	.957	.950	.941	.934	.926
99	.993	.986	.979	.972	.965	.957	.949	.941	.933	.925
100	.993	.986	.979	.972	.965	.957	.949	.940	.932	.924
101	.993	.986	.979	.972	.965	.956	.948	.940	.932	.923
102	.993	.986	.978	.971	.964	.956	.948	.939	.931	.923
103	.993	.986	.978	.971	.964	.955	.947	.939	.931	.922
104	.993	.985	.978	.970	.963	.955	.947	.938	.930	.922
105	.993	.985	.978	.970	.963	.954	.946	.938	.930	.921

1B	% Retained on No. 10 Sieve									
Density	1	2	3	4	5	6	7	8	9	10
106	.992	.985	.977	.970	.962	.954	.945	.937	.929	.920
107	.992	.985	.977	.970	.962	.953	.945	.937	.928	.920
108	.992	.984	.977	.969	.961	.953	.944	.936	.928	.919
109	.992	.984	.977	.969	.961	.952	.944	.936	.927	.919
110	.992	.984	.976	.968	.960	.952	.943	.935	.926	.918
111	.992	.984	.976	.968	.960	.952	.943	.934	.925	.917
112	.992	.984	.976	.968	.960	.951	.942	.933	.924	.916
113	.992	.984	.975	.967	.959	.951	.942	.933	.924	.915
114	.992	.984	.975	.967	.959	.950	.941	.932	.923	.914
115	.992	.984	.975	.967	.959	.950	.941	.931	.922	.913
116	.992	.984	.975	.967	.959	.950	.940	.931	.921	.912
117	.992	.983	.975	.966	.958	.949	.940	.930	.921	.912
118	.992	.983	.975	.966	.958	.949	.939	.930	.920	.911
119	.991	.983	.974	.966	.957	.948	.939	.939	.920	.911
120	.991	.983	.974	.966	.957	.948	.938	.929	.919	.910
121	.991	.983	.974	.966	.957	.947	.937	.928	.918	.909
122	.991	.982	.974	.965	.956	.947	.937	.928	.918	.908
123	.991	.982	.974	.965	.956	.946	.936	.927	.917	.908
124	.991	.982	.973	.964	.955	.946	.936	.927	.917	.907
125	.991	.982	.973	.964	.955	.945	.935	.926	.916	.906
126	.991	.982	.973	.964	.955	.945	.935	.925	.915	.905
127	.991	.982	.973	.964	.955	.944	.934	.925	.915	.905
128	.991	.982	.972	.963	.954	.944	.934	.924	.914	.904
129	.991	.982	.972	.963	.954	.943	.933	.924	.914	.904
130	.991	.982	.972	.963	.954	.943	.933	.923	.913	.903

61C	% Retained on No. 10 Sieve									
Density	11	12	13	14	15	16	17	18	19	20
80	.933	.926	.919	.912	.905	.898	.891	.885	.878	.871
81	.932	.925	.918	.911	.904	.897	.890	.884	.877	.870
82	.931	.924	.917	.910	.903	.896	.889	.882	.875	.868
83	.931	.923	.916	.908	.901	.894	.887	.881	.874	.867
84	.930	.922	.915	.907	.900	.893	.886	.879	.872	.865
85	.929	.921	.914	.906	.899	.892	.885	.878	.871	.864
86	.928	.920	.913	.905	.898	.891	.884	.877	.870	.863
87	.927	.919	.912	.904	.897	.890	.883	.876	.868	.861
88	.926	.919	.911	.904	.896	.889	.881	.874	.867	.860
89	.925	.918	.910	.903	.895	.888	.880	.873	.865	.858
90	.924	.917	.909	.902	.894	.887	.879	.872	.864	.857
91	.923	.916	.908	.901	.893	.886	.878	.871	.863	.856
92	.922	.915	.907	.900	.892	.885	.877	.870	.862	.855
93	.922	.914	.907	.899	.891	.883	.876	.868	.861	.853
94	.921	.913	.906	.898	.890	.882	.875	.867	.860	.852
95	.920	.912	.905	.897	.889	.881	.874	.866	.859	.851
96	.919	.911	.904	.896	.888	.880	.873	.865	.858	.850
97	.918	.910	.903	.895	.887	.879	.872	.864	.857	.849
98	.918	.910	.902	.894	.886	.878	.870	.863	.855	.847
99	.917	.909	.901	.893	.885	.877	.869	.862	.854	.846
100	.916	.908	.900	.892	.884	.876	.868	.861	.853	.845
101	.915	.907	.899	.891	.883	.875	.867	.860	.852	.844
102	.915	.906	.898	.890	.882	.874	.866	.859	.850	.842
103	.914	.906	.898	.888	.881	.873	.865	.857	.849	.841
104	.914	.905	.897	.887	.880	.872	.864	.856	.847	.839
105	.913	.904	.896	.886	.879	.871	.863	.855	.846	.838

Density	11	12	13	14	15	16	17	18	19	20
106	.912	.903	.895	.885	.878	.870	.862	.854	.845	.837
107	.911	.902	.894	.885	.877	.869	.861	.853	.844	.836
108	.911	.902	.894	.884	.876	.868	.859	.851	.842	.834
109	.910	.901	.893	.884	.875	.867	.858	.850	.841	.833
110	.909	.900	.892	.883	.874	.866	.857	.849	.840	.832
111	.908	.899	.891	.882	.873	.865	.856	.848	.839	.831
112	.907	.898	.890	.881	.872	.864	.855	.847	.838	.830
113	.906	.897	.889	.880	.871	.862	.854	.845	.837	.828
114	.905	.896	.888	.879	.870	.861	.853	.844	.836	.827
115	.904	.895	.887	.878	.869	.860	.852	.843	.835	.826
116	.903	.894	.886	.877	.868	.859	.851	.842	.834	.825
117	.903	.894	.885	.876	.867	.858	.850	.841	.833	.824
118	.902	.893	.884	.875	.866	.857	.848	.840	.831	.822
119	.902	.893	.883	.874	.865	.856	.847	.839	.830	.821
120	.901	.892	.882	.873	.864	.855	.846	.838	.829	.820
121	.901	.891	.881	.872	.863	.854	.845	.837	.828	.819
122	.899	.890	.880	.871	.862	.853	.844	.836	.827	.818
123	.899	.890	.880	.871	.862	.853	.844	.834	.825	.816
124	.898	.889	.879	.870	.861	.852	.843	.833	.824	.815
125	.897	.888	.878	.869	.860	.851	.842	.832	.823	.814
126	.896	.887	.877	.868	.859	.850	.841	.831	.822	.813
127	.895	.886	.876	.867	.857	.848	.839	.830	.821	.812
128	.895	.885	.875	.865	.856	.847	.838	.828	.819	.810
129	.894	.884	.874	.864	.854	.845	.836	.827	.818	.809
130	.893	.883	.873	.863	.853	.844	.835	.826	.817	.808

	% Retained on No. 10 Sieve									
Density	21	22	23	24	25	26	27	28	29	30
80	.864	.857	.850	.843	.836	.829	.821	.814	.807	.799
81	.863	.856	.848	.841	.834	.827	.819	.812	.805	.797
82	.861	.854	.847	.840	.833	.825	.817	.810	.803	.795
83	.860	.853	.845	.838	.831	.824	.816	.809	.801	.793
84	.858	.851	.844	.837	.830	.822	.814	.807	.799	.791
85	.857	.850	.842	.835	.828	.820	.812	.805	.797	.789
86	.855	.848	.841	.833	.826	.818	.810	.803	.795	.787
87	.854	.847	.839	.832	.825	.817	.809	.801	.793	.785
88	.853	.845	.838	.830	.823	.815	.807	.799	.791	.783
89	.851	.844	.836	.829	.822	.814	.806	.797	.789	.781
90	.850	.842	.835	.827	.820	.812	.804	.795	.787	.779
91	.849	.841	.834	.826	.819	.810	.802	.793	.785	.777
92	.847	.840	.833	.825	.817	.809	.801	.792	.784	.775
93	.846	.838	.831	.823	.816	.807	.799	.790	.782	.774
94	.844	.837	.830	.822	.814	.806	.798	.789	.781	.772
95	.843	.836	.828	.821	.813	.804	.796	.787	.779	.770
96	.842	.835	.826	.819	.811	.802	.794	.785	.777	.768
97	.841	.833	.825	.817	.809	.800	.792	.783	.775	.766
98	.839	.832	.823	.816	.808	.799	.790	.782	.773	.764
99	.838	.830	.822	.814	.806	.797	.788	.780	.771	.762
100	.837	.829	.820	.812	.804	.795	.786	.778	.769	.760
101	.836	.827	.819	.810	.802	.793	.784	.776	.767	.758
102	.834	.826	.817	.809	.801	.791	.783	.774	.765	.756
103	.833	.824	.816	.807	.799	.790	.781	.772	.763	.754
104	.831	.823	.814	.806	.798	.789	.780	.770	.761	.752
105	.830	.821	.813	.804	.796	.787	.778	.768	.759	.750

6-1F	% Retained on No. 10 Sieve									
Density	21	22	23	24	25	26	27	28	29	30
106	.829	.820	.812	.803	.794	.785	.776	.766	.757	.748
107	.827	.818	.810	.801	.793	.783	.774	.764	.755	.746
108	.826	.817	.809	.800	.791	.782	.773	.763	.754	.744
109	.824	.815	.807	.798	.790	.780	.771	.761	.752	.742
110	.823	.814	.806	.797	.788	.778	.769	.759	.750	.740
111	.822	.813	.804	.795	.786	.776	.767	.757	.748	.738
112	.821	.812	.803	.794	.785	.775	.765	.756	.746	.736
113	.819	.810	.801	.792	.783	.773	.764	.754	.745	.735
114	.818	.809	.800	.791	.782	.772	.762	.753	.743	.733
115	.817	.808	.798	.789	.780	.770	.760	.751	.741	.731
116	.816	.807	.797	.788	.799	.769	.759	.749	.739	.729
117	.815	.805	.796	.786	.777	.767	.757	.747	.737	.727
118	.813	.804	.794	.785	.776	.766	.756	.746	.736	.726

119	.812	.802	.793	.783	.774	.764	.754	.744	.734	.724
120	.811	.801	.792	.782	.773	.763	.753	.742	.732	.722
121	.810	.800	.791	.781	.771	.761	.751	.740	.730	.720
122	.808	.798	.789	.779	.770	.759	.749	.738	.728	.718
123	.807	.797	.788	.778	.768	.758	.748	.737	.727	.716
124	.805	.795	.786	.776	.767	.756	.746	.735	.725	.714
125	.804	.794	.785	.775	.765	.754	.744	.733	.723	.712
126	.803	.793	.784	.774	.764	.753	.742	.731	.721	.710
127	.802	.792	.782	.772	.762	.751	.741	.730	.719	.708
128	.800	.790	.781	.771	.761	.750	.739	.728	.718	.707
129	.799	.789	.781	.769	.759	.748	.737	.727	.716	.705
130	.798	.788	.778	.768	.758	.747	.736	.725	.714	.703

6-1G	% Retained on No. 10 Sieve									
Density	31	32	33	34	35	36	37	38	39	40
80	.791	.783	.775	.767	.759	.750	.741	.732	.723	.713
81	.789	.781	.773	.765	.757	.748	.738	.729	.720	.710
82	.787	.779	.771	.762	.755	.745	.736	.727	.717	.708
83	.785	.776	.768	.760	.752	.743	.733	.724	.715	.705
84	.783	.774	.766	.757	.749	.740	.731	.722	.712	.703
85	.781	.772	.764	.755	.747	.738	.728	.719	.709	.700
86	.779	.770	.762	.753	.745	.735	.726	.716	.707	.687
87	.777	.768	.760	.751	.742	.733	.723	.714	.704	.695
88	.774	.765	.757	.748	.740	.730	.721	.711	.702	.692
89	.772	.763	.755	.746	.737	.728	.718	.709	.699	.690
90	.770	.761	.753	.744	.735	.725	.716	.706	.697	.687
91	.768	.759	.751	.742	.732	.723	.713	.704	.694	.685
92	.766	.757	.748	.739	.730	.721	.711	.701	.692	.682
93	.764	.755	.746	.737	.727	.718	.708	.699	.689	.680

94	.762	.753	.743	.734	.725	.716	.706	.696	.687	.677
95	.760	.751	.741	.732	.722	.713	.703	.694	.684	.675
96	.758	.749	.739	.730	.720	.711	.701	.692	.682	.673
97	.756	.747	.737	.728	.718	.708	.699	.689	.680	.670
98	.754	.744	.735	.725	.715	.706	.696	.687	.677	.668
99	.752	.742	.733	.723	.713	.703	.694	.684	.675	.665
100	.750	.740	.731	.721	.711	.701	.692	.682	.673	.663
101	.748	.738	.729	.719	.709	.699	.690	.680	.671	.661
102	.746	.736	.727	.717	.707	.697	.688	.678	.668	.658
103	.744	.734	.724	.714	.704	.695	.685	.675	.666	.656
104	.742	.732	.722	.712	.702	.693	.683	.673	.663	.653
105	.740	.730	.720	.710	.700	.691	.681	.671	.661	.651

6-1H Density	% Retained on No. 10 Sieve									
	21	22	23	24	25	26	27	28	29	30
106	.738	.728	.718	.708	.698	.689	.679	.669	.659	.649
107	.736	.726	.716	.706	.696	.687	.688	.666	.656	.646
108	.734	.724	.714	.704	.694	.684	.674	.664	.654	.644
109	.732	.722	.712	.702	.692	.682	.672	.661	.651	.641
110	.730	.720	.710	.700	.690	.680	.670	.659	.649	.639
111	.728	.718	.708	.698	.688	.678	.668	.657	.647	.637
112	.726	.716	.706	.696	.686	.676	.666	.655	.645	.635
113	.725	.715	.704	.694	.684	.674	.664	.653	.643	.633
114	.723	.713	.702	.692	.682	.672	.662	.651	.641	.631
115	.721	.711	.700	.690	.680	.670	.660	.649	.639	.629
116	.719	.709	.698	.688	.678	.668	.658	.647	.637	.627
117	.717	.707	.696	.686	.676	.666	.656	.645	.635	.624
118	.716	.705	.695	.684	.674	.663	.653	.642	.632	.622
119	.714	.703	.693	.682	.672	.661	.651	.640	.630	.619

120	.712	.701	.691	.680	.670	.659	.649	.638	.628	.617
121	.710	.699	.689	.678	.668	.657	.647	.636	.626	.615
122	.708	.697	.687	.676	.666	.655	.645	.634	.624	.613
123	.706	.696	.685	.675	.665	.654	.643	.633	.622	.611
124	.704	.694	.683	.673	.663	.652	.641	.631	.620	.609
125	.702	.692	.681	.671	.661	.650	.639	.629	.618	.607
126	.700	.690	.679	.669	.659	.648	.637	.627	.616	.605
127	.698	.688	.677	.667	.657	.646	.635	.625	.614	.603
128	.697	.686	.676	.665	.655	.644	.633	.622	.611	.601
129	.695	.684	.674	.663	.653	.642	.631	.620	.609	.599
130	.693	.682	.672	.661	.651	.640	.629	.618	.607	.597

6-11	% Retained on No. 10 Sieve									
Density	41	42	43	44	45	46	47	48	49	40
80	.704	.695	.686	.676	.667	.657	.647	.638	.628	.618
81	.701	.692	.683	.673	.664	.654	.644	.635	.625	.615
82	.698	.689	.680	.670	.661	.651	.641	.632	.622	.612
83	.696	.687	.677	.668	.658	.648	.638	.628	.618	.608
84	.693	.684	.684	.665	.655	.645	.635	.625	.615	.605
85	.690	.681	.671	.662	.652	.642	.632	.622	.612	.602
86	.687	.678	.668	.659	.649	.639	.629	.619	.609	.599
87	.685	.676	.666	.657	.647	.637	.626	.616	.606	.596
88	.682	.673	.663	.654	.644	.634	.624	.614	.603	.593
89	.680	.671	.661	.652	.642	.632	.621	.611	.600	.590
90	.677	.668	.658	.649	.639	.629	.618	.608	.597	.587
91	.675	.665	.655	.646	.636	.626	.615	.606	.594	.584
92	.672	.663	.652	.643	.633	.623	.612	.602	.591	.581
93	.670	.660	.650	.640	.630	.620	.610	.599	.589	.579
94	.667	.658	.647	.637	.627	.617	.607	.596	.586	.576
95	.665	.655	.644	.634	.624	.614	.604	.593	.583	.573
96	.663	.652	.642	.632	.621	.611	.601	.590	.580	.570
97	.660	.650	.639	.629	.619	.609	.599	.588	.578	.568
98	.658	.647	.637	.626	.616	.606	.596	.585	.575	.565
99	.655	.645	.634	.624	.614	.604	.594	.583	.573	.563
100	.653	.642	.632	.621	.611	.601	.591	.580	.570	.560
101	.650	.640	.630	.619	.609	.599	.588	.578	.568	.557
102	.648	.637	.627	.617	.607	.597	.586	.575	.566	.555
103	.645	.635	.625	.614	.604	.594	.583	.573	.563	.552
104	.643	.632	.622	.612	.602	.592	.581	.570	.560	.550
105	.640	.630	.620	.610	.599	.589	.578	.568	.558	.547

6-1J	% Retained on No. 10 Sieve									
Density	41	42	43	44	45	46	47	48	49	50
106	.638	.628	.618	.607	.597	.587	.576	.566	.555	.545
107	.636	.625	.615	.605	.594	.584	.573	.563	.553	.542
108	.633	.623	.613	.602	.592	.582	.571	.561	.550	.540
109	.631	.620	.610	.600	.589	.579	.568	.558	.548	.537
110	.629	.618	.608	.597	.587	.577	.566	.556	.545	.535
111	.627	.616	.606	.595	.585	.575	.564	.554	.543	.533
112	.625	.614	.604	.593	.582	.572	.561	.552	.540	.531
113	.622	.611	.601	.590	.580	.570	.559	.549	.538	.528
114	.620	.609	.599	.588	.577	.567	.556	.546	.535	.525
115	.618	.607	.597	.586	.575	.565	.554	.544	.533	.523
116	.616	.605	.595	.584	.573	.563	.552	.542	.531	.521
117	.613	.603	.592	.582	.571	.560	.550	.540	.529	.519
118	.611	.600	.590	.579	.568	.558	.549	.537	.527	.517
119	.608	.598	.587	.577	.566	.555	.546	.535	.525	.515
120	.606	.596	.585	.575	.564	.553	.544	.533	.523	.513
121	.604	.594	.583	.573	.562	.551	.542	.531	.521	.511
122	.602	.592	.581	.571	.560	.549	.540	.529	.519	.508
123	.600	.590	.579	.569	.558	.547	.537	.526	.516	.506
124	.598	.588	.577	.567	.556	.545	.535	.524	.514	.503
125	.596	.586	.575	.565	.554	.543	.533	.522	.512	.501
126	.594	.584	.573	.563	.552	.541	.531	.520	.510	.500
127	.592	.582	.571	.561	.550	.539	.529	.518	.508	.498
128	.590	.580	.569	.558	.548	.537	.526	.515	.505	.497
129	.588	.578	.567	.556	.546	.535	.524	.513	.503	.495
130	.586	.576	.565	.554	.544	.533	.522	.511	.501	.494

6-1K	% Retained on No. 10 Sieve									
Density	51	52	53	54	55	56	57	58	59	60
80	.607	.597	.587	.576	.566	.555	.545	.534	.523	.513
81	.604	.594	.584	.573	.563	.552	.542	.530	.519	.509
82	.601	.591	.581	.570	.560	.549	.538	.527	.516	.505
83	.598	.587	.577	.566	.556	.545	.535	.523	.512	.502
84	.595	.584	.574	.563	.553	.542	.531	.520	.509	.498
85	.592	.581	.571	.560	.550	.539	.528	.516	.505	.494
86	.589	.578	.568	.557	.547	.536	.525	.513	.502	.491
87	.586	.575	.564	.554	.544	.533	.522	.510	.499	.488
88	.583	.572	.562	.551	.541	.530	.519	.507	.496	.485
89	.580	.568	.559	.548	.538	.527	.516	.504	.493	.482
90	.577	.566	.556	.545	.535	.524	.513	.501	.490	.479
91	.574	.563	.553	.542	.532	.521	.510	.498	.487	.476
92	.571	.560	.550	.539	.529	.518	.507	.495	.484	.473
93	.569	.558	.548	.537	.527	.515	.504	.492	.481	.469
94	.566	.555	.545	.534	.524	.512	.501	.489	.478	.466
95	.563	.552	.542	.531	.521	.509	.498	.486	.475	.463
96	.560	.549	.539	.528	.518	.506	.495	.483	.472	.460
97	.558	.547	.537	.526	.516	.504	.492	.480	.469	.457
98	.555	.544	.534	.523	.513	.501	.490	.478	.466	.454
99	.553	.542	.532	.521	.511	.499	.487	.475	.463	.451
100	.550	.539	.527	.518	.508	.496	.484	.472	.460	.448
101	.547	.536	.526	.515	.505	.493	.481	.469	.457	.445
102	.544	.534	.523	.512	.502	.490	.478	.466	.454	.443
103	.542	.531	.521	.510	.500	.488	.476	.464	.452	.440
104	.539	.529	.518	.507	.497	.485	.473	.461	.449	.438
105	.536	.526	.515	.504	.494	.482	.470	.458	.446	.435

6-1L	% Retained on No. 10 Sieve									
Density	51	52	53	54	55	56	57	58	59	60
106	.534	.523	.512	.501	.491	.479	.467	.455	.444	.432
107	.531	.521	.510	.499	.488	.476	.465	.453	.441	.430
108	.529	.518	.507	.496	.486	.474	.462	.450	.439	.427
109	.526	.516	.505	.494	.483	.471	.460	.448	.436	.425
110	.524	.513	.502	.491	.480	.468	.457	.445	.434	.422
111	.522	.511	.499	.488	.477	.466	.454	.443	.431	.420
112	.519	.508	.497	.486	.475	.463	.452	.440	.429	.417
113	.517	.506	.494	.483	.472	.461	.449	.438	.426	.415
114	.514	.503	.492	.481	.470	.458	.447	.435	.424	.412
115	.512	.501	.489	.478	.467	.456	.444	.433	.421	.410
116	.510	.499	.487	.476	.465	.454	.442	.431	.419	.408
117	.508	.497	.485	.474	.462	.451	.439	.428	.416	.405
118	.505	.494	.482	.471	.460	.449	.437	.426	.414	.403
119	.503	.492	.480	.469	.457	.446	.434	.423	.411	.400
120	.501	.490	.478	.467	.455	.444	.432	.421	.409	.398
121	.499	.488	.476	.465	.453	.442	.430	.419	.407	.396
122	.496	.485	.473	.462	.450	.439	.428	.417	.405	.394
123	.494	.483	.471	.460	.448	.437	.425	.414	.403	.392
124	.491	.480	.468	.457	.445	.434	.423	.412	.401	.390
125	.489	.478	.466	.455	.443	.432	.421	.410	.399	.388
126	.487	.476	.464	.453	.441	.430	.419	.408	.397	.386
127	.485	.474	.462	.451	.439	.428	.417	.406	.395	.384
128	.482	.471	.459	.448	.436	.425	.414	.403	.392	.381
129	.480	.469	.457	.446	.434	.423	.412	.401	.390	.379
130	.478	.467	.455	.444	.432	.421	.410	.399	.388	.377

STUDY QUESTIONS

GDT 6

Determining the Volume Change of Soils

1. It is ok to use the same mold for both the shrinkage test and the swell test?
 - a) True
 - b) False
2. The metal rammer used for this test shall have a _____ in diameter flat circular face and weigh _____ lbs.
3. When using a mechanical rammer, check the tolerances semi-annually using the procedures in AASHTO ?
4. What is the minimum depth of the water vat required for this test?
5. A flat perforated metal plate with _____ 3/8 in (10 mm) diameter holes located symmetrically under each specimen shall be used to _____ and _____ shrinkage specimens.
6. The three measuring devices shall be readable to and sensitive to _____ in.?
7. The following device is used to measure _____?

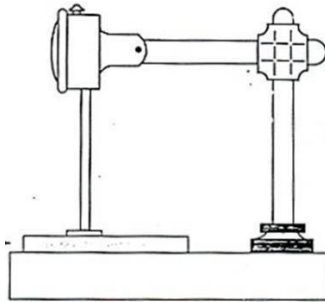

8. A sample mass of _____ should be taken from the materials passing the 2.00-mm (No.10) sieve as obtained according to _____?
9. Optimum moisture content used for this procedure should be determined by _____ or _____?
10. The test sample should be allowed to stand, in a _____, at _____ moisture content, for a _____ of 1 hour?
11. How many freefalls of the hammer are required to compact the swell test specimen?
12. Swell test base plates should be preadjusted, so the micrometer reads _____ on the constant of the calibration tool, with the _____ removed.

13. Swell specimens should remain in the water vat undisturbed for _____ hours before removing the _____ and recording the final _____ measurement?

14. Calculate the percentswell?

Original Dial Reading	.143''
Final Dial Reading	.180''
Swell %	___%

15. The original thickness measurement, when measuring shrinkage, shall be taken before the specimen is extruded from the mold?

- a) True
- b) False

16. Shrinkage specimens shall be allowed to _____ for about _____ hour after compacting and measuring all specimens to be tested?

17. When determining the final diameter dial reading, the _____ end of the specimen should face the same direction as the _____ to ensure proper centering of the specimen?

18. Calculate the percentshrinkage?

B =	.758
FT =	.750
FD =	.740
Shrinkage %	___%

19. Calculate the total volume change using the results from questions No. 14 and No. 18?

Total Volume Change = _____ %

PERFORMANCE CHECKLIST

GDT 6

Determining the Volume Change of Soils

1. Place sample into a plastic bag and thoroughly mix it with enough water to bring the moisture content to optimum.
2. Seal the bag and allow the test sample to stand for a minimum of 1 hour.

Swell Test

3. Place a 4 in. (100 mm) diameter absorbent paper into the assembled swell mold.
4. Place the swell mold under the rammer and place 1/2 of the test sample into the mold.
5. Lower the rammer to touch the soil and compact the test sample with 25 freefalls of the rammer.
6. Remove the mold extension and slice the surface of the specimen flush with the top of the mold.
7. Separate the mold from the base plate, invert, and place onto the absorbent paper and perforated base plate.
8. Use the measuring device in Figure 2 to determine the original swell thickness reading.
9. Place the assembled mold, base plate, and test sample into an empty vat.
10. Slowly fill the vat until the water level is at the top of the mold side pin, but not covering it.
11. Place a wet, absorbent paper, measuring about 4 ½ in. (114 mm) square, on top of the swell specimen so that the corner will be in the water.
12. Allow test specimen to remain in the vat undisturbed for 20 and ½ hours.
13. Remove the absorbent paper and record a final thickness measurement.

Shrinkage Test

14. Place remaining 1/2 of the test sample into the assembled mold, base plate, and extension.
15. Lower the rammer to touch the soil and compact the test sample with 25 freefalls of the rammer.
16. Remove the mold extension and slice the surface of the specimen flush with the top of the mold.
17. Separate the mold, full of soil, from the base plate.
18. Use an extruder to remove the soil cake from the mold.
19. Place the test sample on the measuring stand in Figure 3 and record the original shrinkage thickness dial reading.

20. Place the test specimen on a drying rack and allow to air dry for about 1 hour.
21. Place the drying rack, and test specimen, into the oven at a temperature $230^{\circ} \pm 9^{\circ}\text{F}$ ($110^{\circ} \pm 5^{\circ}\text{C}$) for 20 and 1/2 hours.
22. Remove the rack, and test specimen, from the oven and allow to cool for about 30 minutes.
23. Determine the final thickness dial reading and the final diameter dial reading using the devices in Figure 3 and Figure 4.

SECTION 8

GDT 7

Determining Maximum Density of Soils



GDT 7

A. Scope

For a complete list of GDTs, see the Table of Contents.

Use this test method to determine the relation between moisture content and the theoretical or laboratory maximum dry density. Measure the density in a $1/30 \text{ ft}^3$ ($0.000943, \pm 0.000008 \text{ m}^3$) (Reference ASTM D-698 Mold Volume Calibration) mold compacted by a 5.5 lb (2.5 kg) rammer.

B. Apparatus

The apparatus consists of the following:

1. **Mold:** Use a cylindrical metal mold with an approximate 4 in ($101.6, \pm 0.408 \text{ mm}$) diameter, 4.6 in ($116.43, \pm 0.1270 \text{ mm}$) high, and a volume of $1/30 \text{ ft}^3$ ($0.000943, \pm 0.000008 \text{ m}^3$). The mold is fitted with a detachable base plate and a removable extension approximately 2.5 in (63 mm) high (WM-05) (see Figure 7-1).
This volume to be $1/30 \text{ cubic ft.}$, 4.59 " (1.060 mm^3 , 116 mm) (Reference ASTM D-698 Mold Volume Calibration)
2. **Rammer:** Use a metal rammer with a 2 in ($50.8, \pm 0.127 \text{ mm}$) diameter, flat circular face, and weighing 5.5 lbs. (2.49 kg). The rammer must be equipped with a suitable arrangement to control the height of drop to a free fall of 12 in ($304.8, \pm 1.524 \text{ mm}$) above the soil (WR-1).
3. **Scales and Balances:** Use a scale of 20 kg capacity sensitive to and graduated in 0.1g, and a 500 g capacity balance sensitive to 0.1g.
4. **Drying Device:** Use a stove or oven capable of rapidly drying the moisture determination samples (WS-12).
5. **Straightedge:** Use a steel straightedge 12 in (300 mm) long (WS-13-1).
6. **Pans or Dishes:** Use pie pans or evaporating dishes suitable for drying soil samples (WP-01 or WD-3).
7. **Sieve:** Use a No. 10 (2.00 mm) sieve that conforms to the "Standard Specifications for Sieves for Testing Purposes," AASHTO M 92 (WS-08-#010).
8. **Graduated Cylinder:** Use a glass or plastic (WC-5-100) 3.4 oz. (100 ml) graduated cylinder used to measure the mixing water (Bit-04-100).
9. **Mallet:** Use a wooden mallet or rubber-covered pestle of suitable size (OH-06).
10. **Cup:** Use an 8 oz (237 ml), seamless tin cup (OC-11) for moisture-constant samples.
11. **Extruder (optional):** Use a cylindrical piston slightly less than 4 in (100 mm) diameter or similar device for removing compacted specimens from mold.

C. Sample Size and Preparation

1. Break all the soil aggregations without reducing the natural size of individual particles.
2. Select a representative test sample (about 10 lbs. (5 kg)) by quartering or by using a sampler.
3. Dry the sample only enough to sift over a No. 10 (2.00 mm) sieve. Do not sift yet.
4. Weigh the sifted sample and record the weight as the weight of the total sample.
5. Split the sample into two portions with the No. 10 (2.00 mm) sieve.
6. Grind the fraction retained on the No. 10 (2.00 mm) sieve with a rubber-covered pestle or wooden mallet until the aggregations of soil particles are broken up into separate grains.

7. Separate the ground soil into two fractions again with the No. 10 (2.00mm)sieve.
8. Weigh the fraction retained on the No. 10 (2.00 mm)sieve after the secondsieving.

9. Record the weight as the weight of material retained on the No. 10 (2.00 mm) sieve.

D. Procedures

1. Thoroughly mix both fractions that passed the No. 10 (2.00 mm) sieve in both sieving operations.
2. Take a 6.6 lb (3000 g) sample from the minus No. 10 (2.00 mm) material by quartering or by using a sampler.
3. Attach the extension to the cylinder.
4. Compact the sample in the cylinder in three equal layers.
 - a. Compact each layer with 25 blows from the rammer dropped from 1 ft (304.8 mm) above the soil.
 - b. Rest the mold on a uniform, rigid foundation, such as a concrete block weighing at least 200 lbs (90 kg).
 - c. Uniformly distribute the blows over the surface of the compacted layer.
 - d. Remove the soil that adheres to the face of the rammer after every 25th blow.
5. After compacting, remove the extension and base plate.
6. Carefully level the compacted soil to the top and bottom of the cylinder with the straight edge.
7. Weigh the cylinder and sample together.
8. Calculate the wet weight of the compacted soil in pounds per cubic foot as follows:

$$\text{Wet Weight of Compacted Soil (lbs./ft}^3\text{)} = \frac{(\text{Ws}-\text{Wc})/453.6}{\text{V}} \text{ or } \frac{(\text{Ws}-\text{Wc}) * \text{Mold Factor}}{453.6} \text{ or } (\text{Ws}-\text{Wc}) * \text{C.F.C}$$

V = Volume in lbs./ft³ of the Mold as calibrated Using (Reference ASTM D-698 Mold Volume Calibration)

Mold Factor = calculated 1/volume lbs./ft³

C.F.C = Correction Factor Conversion =

Mold Factor/453.6 W_s = weight of the compacted soil and mold, in grams

W_c = weight of the mold, in grams

If you weighed in grams, dividing by 453.6 converts grams to pounds. This will give you the wet weight in pounds per cubic foot.

9. Remove the compacted soil from the cylinder and slice it vertically through its center.
10. Take a 100 g sample from the center and weigh it immediately.
11. Dry the sample to a constant weight.
12. Calculate the moisture content of the soil as follows:
13. Moisture (%) = $\frac{A - B}{B} \times 100$

B

where:

A = weight of the wet soil

B = weight of the dry soil

14. Thoroughly pulverize the remaining material from the compacted sample.
15. Add enough water to increase the moisture content of the soil in predetermined increments (1 percent to 2 percent for sandy soils, 2 percent to 3 percent for clay soils).
 - a. For a 5.94 lb (2.7 kg) sample, add 0.9 oz (27 ml) of water to increase the moisture content by 1 percent.

- b. For a 6.6 lb (3000 g) sample, add 1 oz (30 ml) of water.
- 16. Repeat steps 1 through 13 again, taking a moisture sample after each determination.
- 17. Repeat the procedure until the soil becomes very wet and the wet weight of the compacted soil substantially decreases.

E. Calculations (CVP 7)

- 1. Calculate wet density:

$$\text{Wet Density} = \frac{(W_s - W_c)/453.6}{\text{C.F.C.} \cdot V} \text{ or } \frac{(W_s - W_c) * \text{Mold Factor}}{453.6} \text{ or } \frac{(W_s - W_c) *}{453.6}$$

where:

- V = Volume of the Mold as calibrated Using (Ref. ASTM D-698, CVP 7)
- Mold Factor = Calculated 1/volume lbs/ft³ (Ref. CVP 7)
- C.F.C = Correction Factor Conversion (GDOT Correction Factor) = Mold Factor/453.6 (Ref. CVP 7)
- W_c = Weight of mold in grams
- W_s = Weight of mold + wet soil in grams

- 2. Calculate percent moisture:

$$\% \text{ Moisture} = \frac{A - B}{B} \times 100$$

where:

- A = Weight of wet soil
- B = Weight of dry soil

- 3. Calculate the density (dry weight), in pounds per cubic foot (kilograms per cubic meter), of the compacted soil as follows:

$$\text{English—Dry Density (lb/ft}^3\text{)} = \frac{W_w}{M + 100} \times 100$$

where:

- W_w = wet weight of the compacted soil, in pounds per cubic foot (Procedures, step D.8)
- M = moisture content, in percent, at which the wet weight was determined (Procedures, step D.12)

- 4. Moisture-Density Relationship

- a. Calculate and record the percent moisture and dry density for each determination in the series.
- b. When using the moisture-density relationship for compaction control:
 - i. Plot a moisture-density curve by plotting the dry densities against their respective moisture contents.
 - ii. Draw a smooth curve through the resulting points.
 - iii. The peak of the curve represents the maximum dry density of the material being tested, and the moisture content at this point represents the optimum moisture content.

- c. For classification purposes, interpret the maximum dry density as the highest density obtained in the test series, and the optimum moisture as the moisture content at that respective density.
- 5. Correction for Plus No. 10 (2.00 mm) Material
 - d. If the soil contains material retained on the No. 10 (2.00 mm) sieve and the specifications show density requirements on the total sample, you must correct the maximum dry density to reflect the percentage of Plus No. 10 (2.00 mm) material.
 - e. When determining maximum densities for compaction control, always correct the densities for the percentage of Plus No. 10 (2.00 mm) material.
- f. Use the conversion factors for correcting the density in Tables 1D - 7D, below.
- g. Use the conversion factors for correcting the moisture of Minus No. 10 (2.00 mm) for the Plus No. 10 (2.00 mm) in Tables 1M - 10M, below.

F. Report

- 1. Record the maximum dry density and the optimum moisture content of the material being tested as the theoretical or laboratory maximum dry density on Form 495.
- 2. Send the completed original form to the Office of Materials and Research in Forest Park.
- 3. Send copies of the form to the Branch Lab and the Area Engineer.
- 4. Notify the department head of any material that fails.

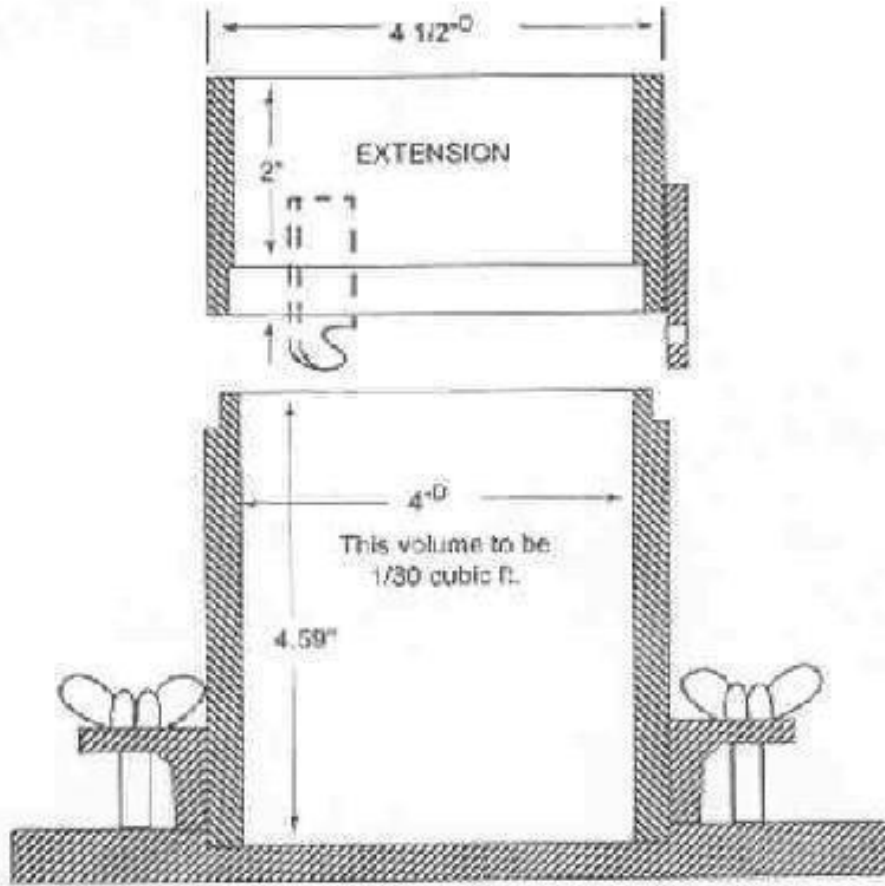

Figure 7-1

GDT 7

TABLE 1D FOR % PLUS NO. 10 IN TOTAL SAMPLE

% Plus No. 10 Material by Weight in Total Sample

-10 Density	1	2	3	4	5	6	7
130	130.1	130.2	130.3	130.4	130.5	130.6	130.7
129	129.1	129.2	129.3	129.4	129.5	129.6	129.7
128	128.1	128.2	128.3	128.5	128.6	128.7	128.8
127	127.1	127.3	127.4	127.5	127.6	127.8	127.9
126	126.1	126.3	126.4	126.5	126.7	126.8	126.9
125	125.2	125.3	125.4	125.6	125.7	125.9	126.0
124	124.2	124.3	124.5	124.6	124.8	124.9	125.1
123	123.2	123.3	123.5	123.6	123.8	124.0	124.1
122	122.2	122.3	122.5	122.7	122.9	123.0	123.2
121	121.2	121.4	121.5	121.7	121.9	122.1	122.2
120	120.2	120.4	120.6	120.7	120.9	121.1	121.3
119	119.2	119.4	119.6	119.8	120.0	120.2	120.4
118	118.2	118.4	118.6	118.8	119.0	119.2	119.4
117	117.2	117.4	117.6	117.9	118.1	118.3	118.5
116	116.2	116.4	116.7	116.9	117.1	117.3	117.6
115	115.2	115.5	115.7	115.9	116.2	116.4	116.6
114	114.3	114.5	114.7	115.0	115.2	115.4	115.7
113	113.3	113.5	113.8	114.0	114.3	114.5	114.8
112	112.3	112.5	112.8	113.0	113.3	113.6	113.8
111	111.3	111.5	111.8	112.1	112.3	112.6	112.9
110	110.3	110.6	110.8	111.1	111.4	111.7	111.9
109	109.3	109.6	109.9	110.1	110.4	110.7	111.0
108	108.3	108.6	108.9	109.2	109.5	109.8	110.1
107	107.3	107.6	107.9	108.2	108.5	108.8	109.1
106	106.3	106.6	106.9	107.3	107.6	107.9	108.2
105	105.3	105.6	106.0	106.3	106.6	106.9	107.3

104	104.3	104.7	105.0	105.3	105.7	106.0	106.3
103	103.3	103.7	104.0	104.4	104.7	105.0	105.4
102	102.4	102.7	103.0	103.4	103.7	104.1	104.4
101	101.4	101.7	102.1	102.4	102.8	103.1	103.5
100	100.4	100.7	101.1	101.5	101.8	102.2	102.6
99	99.4	99.8	100.1	100.5	100.9	101.3	101.6
98	98.4	98.8	99.2	99.5	99.9	100.3	100.7
97	97.4	97.8	98.2	98.6	99.0	99.4	99.8
96	96.4	96.8	97.2	97.6	98.0	98.4	98.8
95	95.4	95.8	96.2	96.6	97.1	97.5	97.9
94	94.4	94.8	95.3	95.7	96.1	96.5	96.9
93	93.4	93.9	94.3	94.7	95.1	95.6	96.0
92	92.4	92.9	93.3	93.8	94.2	94.6	95.1
91	91.5	91.9	92.3	92.8	93.2	93.7	94.1
90	90.5	90.9	91.4	91.8	92.3	92.7	93.2
89	89.5	89.9	90.4	90.9	91.3	91.8	92.3
88	88.5	88.9	89.4	89.9	90.4	90.8	91.3

GDT 7

87	87.5	88.0	88.4	88.9	89.4	89.9	90.4
86	86.5	87.0	87.5	88.0	88.5	89.0	89.4
85	85.5	86.0	86.5	87.0	87.5	88.0	88.5
84	84.5	85.0	85.5	86.0	86.6	87.1	87.6
83	83.5	84.0	84.6	85.1	85.6	86.1	86.6
82	82.5	83.1	86.3	84.1	84.6	85.2	85.7
81	81.5	82.1	82.6	83.1	83.7	84.2	84.8

G

TABLE 2D FOR % PLUS NO. 10 IN TOTALSAMPLE
 % Plus No. 10 Material by Weight in TotalSample

-10 Density	8	9	10	11	12	13	14
130	130.8	130.9	131.0	131.1	131.2	131.3	131.4
129	129.8	130.0	130.1	130.2	130.3	130.4	130.5
128	128.9	129.0	129.2	129.3	129.4	129.5	129.6
127	128.0	128.1	128.3	128.4	128.5	128.6	128.8
126	127.1	127.2	127.3	127.5	127.6	127.7	127.9
125	126.1	126.3	126.3	126.4	126.6	126.9	127.0
124	125.2	125.4	125.5	125.7	125.8	126.0	126.1
123	124.3	124.4	124.6	124.8	124.9	125.1	125.3
122	123.4	123.5	123.7	123.9	124.0	124.2	124.4
121	122.4	122.6	122.8	123.0	123.1	123.3	123.5
120	121.5	121.7	121.9	122.1	122.2	122.4	122.6
119	120.6	120.8	121.0	121.2	121.4	121.5	121.7
118	119.6	119.8	120.1	120.3	120.5	120.7	120.9
117	118.7	118.9	119.1	119.4	119.6	119.8	120.0
116	117.8	118.0	118.2	118.5	118.7	118.9	119.1
115	116.9	117.1	117.3	117.6	117.8	118.0	118.2
114	115.9	116.2	116.4	116.7	116.9	117.1	117.4
113	115.0	115.3	115.5	115.8	116.0	116.3	116.5
112	114.1	114.3	114.6	114.8	115.1	115.4	115.6
111	113.1	113.4	113.7	113.9	114.2	114.5	114.8
110	112.2	112.5	112.8	113.0	113.3	113.6	113.9
109	111.3	111.6	111.9	112.1	112.4	112.7	113.0
108	110.4	110.7	111.0	111.2	111.5	111.8	112.1
107	109.4	109.7	110.0	110.3	110.6	111.0	111.3
106	108.5	108.8	109.1	109.4	109.8	110.1	110.4
105	107.6	107.9	108.2	108.5	108.9	109.2	109.5
104	106.6	107.0	107.3	107.6	108.0	108.3	108.6
103	105.7	106.1	106.4	106.7	107.1	107.4	107.8
102	104.8	105.1	105.5	105.8	106.2	106.5	106.9
101	103.9	104.2	104.6	104.9	105.3	105.7	106.0
100	102.9	103.3	103.7	104.0	104.4	104.8	105.1
99	102.0	102.4	102.8	103.1	103.5	103.9	104.3
98	101.1	101.5	101.9	102.2	102.6	103.0	103.4
97	100.2	100.5	100.9	101.3	101.7	102.1	102.5
96	99.2	99.6	100.0	100.4	100.8	101.2	101.6
95	98.3	98.7	99.1	99.5	99.9	100.3	100.8
94	97.4	97.8	98.2	98.6	99.0	99.5	99.9
93	96.4	96.9	97.3	97.7	98.1	98.6	99.0
92	95.5	95.9	96.4	96.8	97.3	97.7	98.1
91	94.6	95.0	95.5	95.9	96.4	96.8	97.3

GDT 7

90	93.6	94.1	94.6	95.0	95.5	95.9	96.4
89	92.7	93.2	93.7	94.1	94.6	95.0	95.5
88	91.8	92.3	92.7	93.2	93.7	94.2	94.6
87	90.9	91.3	91.8	92.3	92.8	93.3	93.8
86	89.9	90.4	90.9	91.4	91.9	92.4	92.9
85	89.0	89.5	90.0	90.5	91.0	91.5	92.0
84	88.1	88.6	89.1	89.6	90.1	90.6	91.1
83	87.2	87.7	88.2	88.7	89.2	89.7	90.3
82	86.2	86.8	87.3	87.8	88.3	88.9	89.4
81	85.3	85.8	86.4	86.9	87.4	88.0	88.5

GDT 7

TABLE 3D FOR % PLUS NO. 10 IN TOTALSAMPLE
 % Plus No. 10 Material by Weight in TotalSample

-10 Density	15	16	17	18	19	20	21
130	131.5	131.6	131.7	131.8	131.9	132.0	132.1
129	130.6	130.7	130.8	130.9	131.0	131.1	131.2
128	129.7	129.9	130.0	130.1	130.2	130.3	130.4
127	128.9	129.0	129.1	129.3	129.4	129.5	129.6
126	128.0	128.1	128.3	128.4	128.5	128.7	128.8
125	127.1	127.3	127.4	127.6	127.7	127.9	128.0
124	126.3	126.4	126.6	126.7	126.9	127.0	127.2
123	125.4	125.6	125.7	125.9	126.1	126.2	126.4
122	124.6	124.7	124.9	125.1	125.2	125.4	125.6
121	123.7	123.8	124.0	124.2	124.4	124.6	124.7
120	122.8	123.0	123.2	123.4	123.6	123.7	123.9
119	121.9	122.1	122.3	122.5	122.7	122.9	123.1
118	121.1	121.3	121.5	121.7	121.9	122.1	122.3
117	120.2	120.4	120.6	120.9	121.1	121.3	121.5
116	119.3	119.6	119.8	120.0	120.2	120.5	120.7
115	118.5	118.7	118.9	119.2	119.4	119.6	119.9
114	117.6	117.9	118.1	118.3	118.6	118.8	119.1
113	116.8	117.0	117.3	117.5	117.8	118.0	118.3
112	115.9	116.1	116.4	116.7	116.9	117.2	117.4
111	115.0	115.3	115.6	115.8	116.1	116.4	116.6
110	114.2	114.4	114.7	115.0	115.3	115.5	115.8
109	113.3	113.6	113.9	114.1	114.4	114.7	115.0
108	112.4	112.7	113.0	113.3	113.6	113.9	114.2
107	111.6	111.9	112.2	112.5	112.8	113.1	113.4
106	110.7	111.0	111.3	111.6	111.9	112.3	112.6
105	109.8	110.2	110.5	110.8	111.1	111.4	111.8
104	109.0	109.3	109.6	110.0	110.3	110.6	111.0
103	108.1	108.4	108.8	109.1	109.5	109.8	110.0
102	107.2	107.6	107.9	108.3	108.6	109.0	109.3
101	106.4	106.7	107.1	107.4	407.8	108.2	108.5
100	105.5	105.9	106.2	106.6	107.0	107.3	107.7
99	104.6	105.0	105.4	105.8	106.1	106.5	106.9
98	103.8	104.2	104.5	104.9	105.3	105.7	106.1
97	102.9	103.3	103.7	104.1	104.5	104.9	105.3
96	102.0	102.4	102.8	103.2	103.6	104.0	104.4
95	101.2	101.6	102.0	102.4	102.8	103.2	103.6
94	100.3	100.7	101.1	101.6	102.0	102.4	102.8
93	99.4	99.9	100.3	100.7	101.2	101.6	102.0

GDT 7

92	98.6	99.0	99.4	99.9	100.3	100.8	101.2
91	97.7	98.2	98.6	99.0	99.5	99.9	100.4
90	96.8	97.3	97.8	98.2	98.7	99.1	99.6
89	96.0	96.4	96.9	97.4	97.8	98.3	98.8
88	95.1	95.6	96.1	96.5	97.0	97.5	98.0
87	94.2	94.7	95.2	95.7	96.2	96.7	97.1
86	93.4	93.9	94.4	94.9	95.3	95.8	96.3
85	92.5	93.0	93.5	94.0	94.5	95.0	95.5
84	91.7	92.2	92.7	93.2	93.7	94.2	94.7
83	90.8	91.3	91.8	92.3	90.9	93.4	93.9
82	89.9	90.4	91.0	91.5	92.0	92.6	93.1
81	89.1	89.6	90.1	90.7	91.2	91.7	92.3

TABLE 4D FOR % PLUS NO. 10 IN TOTALSAMPLE
 % Plus No. 10 Material by Weight in TotalSample

-10 Density	22	23	24	25	26	27	28
130	132.2	132.3	132.4	132.5	132.5	132.6	132.7
129	131.4	131.5	131.6	131.7	131.8	131.9	132.0
128	130.6	130.7	130.8	130.9	131.0	131.1	131.2
127	129.8	129.9	130.0	130.1	130.3	130.4	130.5
126	128.9	129.1	129.2	129.4	129.5	129.6	129.8
125	128.1	128.3	128.4	128.6	128.7	128.9	129.0
124	127.3	127.5	127.6	127.8	128.0	128.1	128.3
123	126.5	126.7	126.9	127.0	127.2	127.3	127.5
122	125.7	125.9	126.1	126.3	126.4	126.6	126.8
121	124.9	125.1	125.3	125.5	125.6	125.8	126.0
120	124.1	124.3	124.5	124.7	124.9	125.0	125.0
119	123.3	123.5	123.7	123.9	124.1	124.3	124.5
118	122.5	122.7	122.9	123.1	123.3	123.5	123.7
117	121.7	121.9	122.1	122.4	122.6	122.8	123.0
116	120.9	121.1	121.4	121.6	121.8	122.0	122.2
115	120.1	120.3	120.6	120.8	121.0	121.3	121.5
114	119.3	119.5	119.8	120.0	120.3	120.5	120.7
113	118.5	118.8	119.0	119.3	119.5	119.8	120.0
112	117.7	118.0	118.2	118.5	118.7	119.0	119.3
111	116.9	117.2	117.4	117.7	118.0	118.2	118.5
110	116.1	116.4	116.6	116.9	117.2	117.5	117.8
109	115.3	115.6	115.9	116.2	116.4	116.7	117.0
108	114.5	114.8	115.1	115.4	115.7	116.0	116.3
107	113.7	114.0	114.3	114.6	114.9	115.2	115.5
106	112.9	113.2	113.5	113.8	114.1	114.5	114.8
105	112.1	112.4	112.7	113.1	113.4	113.7	114.0
104	111.3	111.6	111.9	112.3	112.6	112.9	113.3
103	110.5	110.8	111.2	111.5	111.8	112.2	112.5
102	109.7	110.0	110.4	110.7	111.1	111.4	111.8
101	108.9	109.2	109.6	110.0	110.3	110.7	111.0
100	108.1	108.4	108.8	109.2	109.5	109.9	110.3
99	107.3	107.6	108.0	108.4	408.8	109.2	109.5
98	106.5	106.9	107.2	107.6	108.0	108.4	108.8
97	105.7	106.1	106.5	106.9	107.2	107.6	108.0
96	104.8	105.2	105.6	106.1	106.5	106.9	107.3
95	104.0	104.5	104.9	105.3	105.7	106.1	106.5
94	103.2	103.7	104.1	104.5	104.9	105.3	105.8

GDT 7

93	102.4	102.9	103.3	103.7	104.2	104.6	105.0
92	101.6	102.1	102.5	103.0	103.4	103.8	104.3
91	100.8	101.3	101.7	102.2	102.6	103.1	103.5
90	100.0	100.5	100.9	101.4	101.9	102.3	102.8
89	99.2	99.7	100.2	100.6	101.1	101.6	102.0
88	98.4	98.9	99.4	99.9	100.3	100.8	101.3
87	97.6	98.1	98.6	99.1	99.6	100.0	100.5
86	96.8	97.3	97.8	98.3	98.8	99.3	99.8
85	96.0	96.5	97.0	97.5	98.0	98.5	99.0
84	95.2	95.7	96.2	96.8	97.3	97.8	98.3
83	94.4	94.9	95.5	96.0	96.5	97.0	97.5
82	93.6	94.1	94.7	95.2	95.7	96.3	96.8
81	92.8	93.4	93.9	94.4	95.0	95.5	96.0

GDT 7

TABLE 5D FOR % PLUS NO. 10 IN TOTALSAMPLE
 % Plus No. 10 Material by Weight in TotalSample

-10 Density	29	30	31	32	33	34	35
130	132.8	132.9	133.0	133.1	133.2	133.3	133.4
129	132.1	132.2	132.3	132.4	132.5	132.6	132.7
128	131.4	131.5	131.6	131.7	131.8	131.9	132.1
127	130.6	130.8	130.9	131.0	131.1	131.3	131.4
126	129.9	130.0	130.2	130.3	130.4	130.6	130.7
125	129.1	129.3	129.4	129.6	129.7	129.8	130.0
124	128.4	128.6	128.7	128.9	129.0	129.2	129.3
123	127.7	127.8	128.0	128.2	128.3	128.5	128.6
122	126.9	127.1	127.3	127.4	127.6	127.8	128.0
121	126.2	126.3	126.5	126.7	126.9	127.1	127.2
120	125.4	125.6	125.8	126.0	126.2	126.4	126.5
119	124.7	124.9	125.1	125.3	125.5	125.7	125.9
118	123.9	124.2	124.4	124.6	124.8	125.0	125.2
117	123.2	123.4	123.6	123.8	124.1	124.3	124.5
116	122.5	122.7	122.9	123.1	123.4	123.6	123.8
115	121.7	122.0	122.2	122.4	122.7	122.9	123.1
114	121.0	121.2	121.5	121.7	122.0	122.2	122.4
113	120.3	120.5	120.8	121.0	121.3	121.5	121.8
112	119.5	119.8	120.0	120.3	120.5	120.8	121.1
111	118.8	119.0	119.3	119.6	119.8	120.1	120.4
110	118.0	118.3	118.6	118.9	119.1	119.4	119.7
109	117.3	117.6	117.9	118.2	118.4	118.7	119.0
108	116.6	116.9	117.1	117.4	117.7	118.0	118.3
107	115.8	116.1	116.4	116.7	117.0	117.3	117.6
106	115.1	115.4	115.7	116.0	116.3	116.6	117.0
105	114.3	114.7	115.0	115.3	115.6	115.9	116.3
104	113.6	113.9	114.3	114.6	114.9	115.3	115.6
103	112.9	113.2	113.5	113.9	114.2	114.6	114.9
102	112.1	112.5	112.8	113.2	113.5	113.9	114.2
101	111.4	111.7	112.1	112.5	112.8	113.2	113.5
100	110.6	111.0	111.4	111.7	112.1	112.5	112.8
99	109.9	110.3	110.7	111.0	111.4	111.8	112.2
98	109.2	109.6	109.9	110.3	110.7	111.1	111.5
97	108.4	408.8	109.2	109.6	110.0	110.4	110.8
96	107.7	108.1	108.5	108.9	109.3	109.7	110.1
95	106.9	107.3	107.7	108.2	108.6	109.0	109.4
94	106.2	106.6	107.0	107.4	107.9	108.3	108.7
93	105.4	105.9	106.3	106.7	107.2	107.6	108.0
92	104.7	105.1	105.6	106.0	106.5	106.9	107.3
91	104.0	104.4	104.9	105.3	105.8	106.2	106.6

GDT 7

90	103.2	103.7	104.1	104.6	105.0	105.5	106.0
89	102.5	103.0	103.4	103.9	104.3	104.8	105.3
88	101.7	102.2	102.7	103.2	103.6	104.1	104.6
87	101.0	101.5	102.0	102.5	102.9	103.4	103.9
86	100.3	100.8	101.3	101.7	102.2	102.7	103.2
85	99.5	100.0	100.5	101.0	101.5	102.0	102.5
84	98.8	99.3	99.8	100.3	100.8	101.3	101.9
83	98.1	98.6	99.1	99.6	100.1	100.6	101.2
82	97.3	97.8	98.4	98.9	99.4	100.0	100.5
81	96.6	97.1	97.6	98.2	98.7	99.3	99.8

GDT 7

TABLE 6D FOR % PLUS NO. 10 IN TOTALSAMPLE
 % Plus No. 10 Material by Weight in TotalSample

-10 Density	36	37	38	39	40	41	42
130	133.5	133.6	133.7	133.8	133.9	134.0	134.1
129	132.9	133.0	133.1	133.2	133.3	133.4	133.5
128	132.2	132.3	132.4	132.5	132.6	132.8	132.9
127	131.5	131.6	131.8	131.9	132.0	132.1	132.3
126	130.8	131.0	131.1	131.2	131.4	131.5	131.6
125	130.1	130.3	130.4	130.6	130.7	130.9	131.0
124	129.5	129.6	129.8	129.9	130.1	130.2	130.4
123	128.8	129.0	129.1	129.3	129.4	129.6	129.8
122	128.1	128.3	128.5	128.6	128.8	129.0	129.1
121	127.4	127.6	127.8	127.9	128.1	128.3	128.5
120	126.7	126.9	127.1	127.3	127.5	127.7	127.9
119	126.1	126.3	126.4	126.6	126.8	127.0	127.2
118	125.4	125.6	125.8	126.0	126.2	126.4	126.6
117	124.7	124.9	125.1	125.3	125.6	125.8	126.0
116	124.0	124.3	124.5	124.7	124.9	125.1	125.4
115	123.4	123.6	123.8	124.0	124.3	124.5	124.7
114	122.7	122.9	123.2	123.4	123.6	123.9	124.1
113	122.0	122.3	122.5	122.8	123.0	123.3	123.5
112	121.3	121.6	121.8	122.1	122.4	122.6	122.9
111	120.6	120.9	121.2	121.5	121.7	122.0	122.3
110	120.0	120.2	120.5	120.8	121.1	121.4	121.6
109	119.3	119.6	119.9	120.2	120.4	120.7	121.0
108	118.6	118.9	119.2	119.5	119.8	120.1	120.4
107	117.9	118.2	118.6	118.9	119.2	119.5	119.8
106	117.3	117.6	117.9	118.2	118.5	118.8	119.1
105	116.6	116.9	117.2	117.6	117.9	118.2	118.5
104	115.9	116.2	116.6	116.9	117.2	117.6	117.9
103	115.2	115.6	115.9	116.3	116.6	116.9	117.3
102	114.6	114.9	115.3	115.6	116.0	116.3	116.7
101	113.9	114.2	114.6	115.0	115.3	115.7	116.0
100	113.2	113.6	113.9	114.3	114.7	115.0	115.4
99	112.5	112.9	113.3	113.7	114.0	114.4	114.8
98	111.9	112.2	112.6	113.0	113.4	113.8	114.2
97	111.2	111.6	112.0	112.4	112.8	113.2	113.5
96	110.5	110.9	111.3	111.7	112.1	112.5	112.9
95	109.8	110.2	110.6	111.0	111.4	111.9	112.3
94	109.1	109.5	110.0	110.4	110.8	111.2	111.6
93	108.4	108.9	109.3	109.7	110.2	110.6	111.0
92	107.8	108.2	108.6	109.1	109.5	110.0	110.4
91	107.1	107.5	108.0	108.4	108.9	109.3	109.8

GDT 7

90	106.4	106.9	107.3	107.8	108.2	108.7	109.2
89	105.7	106.2	106.7	107.1	107.6	108.1	108.5
88	105.1	105.5	106.0	106.5	107.0	107.4	107.9
87	104.4	104.9	105.4	105.8	106.3	106.8	107.3
86	103.7	104.2	104.7	105.2	105.7	106.2	106.7
85	103.0	103.5	104.0	104.5	105.0	105.5	106.0
84	102.4	102.9	103.4	103.9	104.4	104.9	105.4
83	101.7	102.2	102.7	103.2	103.8	104.3	104.8
82	101.0	101.5	102.1	102.6	103.1	103.6	104.2
81	100.3	100.9	101.4	101.9	102.5	103.0	103.6

TABLE 7D FOR % PLUS NO 10 IN TOTALSAMPLE
 % PLUS NO 10 Material by Weight Total Sample

-10 Density	43	44	45
130	134.2	134.3	134.4
129	133.6	133.7	133.8
128	133.0	133.1	133.2
127	132.4	132.5	132.6
126	131.8	131.9	132.0
125	131.1	131.3	131.4
124	130.5	130.7	103.8
123	129.9	130.1	130.2
122	129.3	129.5	129.7
121	128.7	128.8	139.0
120	128.0	128.2	128.8
119	127.4	127.6	127.8
118	126.8	127.0	127.2
117	126.2	126.4	126.6
116	125.6	125.8	126.0
115	125.0	125.2	125.4
114	124.4	124.6	124.8
113	123.8	124.0	124.3
112	123.1	123.4	123.7
111	122.5	122.8	123.1
110	121.9	122.2	122.5
109	121.3	121.6	121.9
108	120.7	121.0	121.3
107	120.1	120.4	120.7
106	119.5	119.8	120.1
105	118.8	119.2	119.5
104	118.2	118.6	118.9
103	117.6	118.0	118.3
102	117.0	117.4	117.7
101	116.4	116.8	117.1
100	115.8	116.1	116.5
99	115.2	115.5	115.9
98	114.6	114.9	115.3
97	113.9	114.3	114.7
96	113.3	113.7	114.1
95	112.7	113.1	113.5
94	112.1	112.5	112.9
93	111.4	111.9	112.3
92	110.8	111.3	111.7

GDT 7

91	110.2	110.7	111.1
90	109.7	110.1	110.5
89	109.0	109.5	109.9
88	108.4	108.9	109.3
87	107.8	108.3	108.7
86	107.2	107.6	108.1
85	106.5	107.0	107.5
84	105.9	106.4	107.0
83	105.3	105.8	106.4
82	104.7	105.2	105.8
81	104.1	104.6	105.2

GDT 7

**TABLE 77M—MOISTURE CORRECTION OF MINUS NO. 10 FOR % PLUS No. 10 (FOR + 10 ABSORPTION OF 1%)
% Plus No. 10 Material by Weight in Total Sample**

-10 Moisture	5	10	15	20	25
40	38.1	36.1	34.2	32.2	30.3
39	37.1	35.2	33.3	31.4	29.5
38	36.2	34.3	32.5	30.6	28.8
37	35.2	33.4	31.6	29.8	28.0
36	34.3	32.5	30.8	29.0	27.3
35	33.3	31.6	29.9	28.2	26.5
34	32.4	30.7	29.1	27.4	25.8
33	31.4	29.8	28.2	26.6	25.0
32	30.5	28.9	27.4	25.8	24.3
31	29.5	28.0	26.5	25.0	23.5
30	28.6	27.1	25.7	24.2	22.8
29	27.6	26.2	24.8	23.4	22.0
28	26.7	25.3	23.9	22.6	21.3
27	25.7	24.2	23.1	21.8	20.5
26	24.8	23.5	22.3	21.0	19.8
25	23.8	22.6	21.4	20.2	19.0
24	22.9	21.7	20.6	19.4	18.3
23	21.9	20.8	19.7	18.6	17.5
22	21.0	19.9	18.9	17.8	16.8
21	20.0	19.0	18.0	17.0	16.0
20	19.1	18.1	17.2	16.2	15.3
19	18.1	17.2	16.3	15.4	14.5
18	17.2	16.3	15.5	14.6	13.8
17	16.2	15.4	14.6	13.8	13.0
16	15.3	14.6	13.8	13.0	12.3
15	14.3	13.6	12.9	12.2	11.5
14	13.4	12.7	12.1	11.4	10.8
13	12.4	11.8	11.2	10.6	10.0
12	11.5	11.0	10.4	9.8	9.3
11	10.5	10.0	9.5	9.0	8.5
10	9.6	9.1	8.7	8.2	7.8
9	8.6	8.2	7.8	7.4	7.0
8	7.7	7.3	7.0	6.6	6.3
7	6.7	6.4	6.1	5.8	5.5
6	5.8	5.5	5.3	5.0	4.8
5	4.8	4.6	4.4	4.2	4.0
4	3.9	3.7	3.6	3.4	3.3
3	2.9	2.8	2.7	2.6	2.5
2	2.0	1.9	1.9	1.8	1.8

GDT 7

TABLE 78M—MOISTURE CORRECTION OF MINUS NO. 10 FOR % PLUS No. 10 (FOR + 10 ABSORPTION OF 1%)
 % Plus No. 10 Material by Weight in Total Sample

-10 Moisture	30	35	40	45
40	28.3	26.4	24.4	22.5
39	27.6	25.7	23.8	21.9
38	26.9	25.1	23.2	21.4
37	26.2	24.4	22.6	20.8
36	25.5	23.8	22.0	20.3
35	24.8	23.1	21.4	19.7
34	24.1	22.5	20.8	19.2
33	23.4	21.8	20.2	18.6
32	22.7	21.2	19.6	18.1
31	22.0	20.5	19.0	17.5
30	21.3	19.9	18.4	17.0
29	20.6	19.2	17.8	16.4
28	19.9	18.6	17.2	15.9
27	19.2	17.9	16.6	15.3
26	18.5	17.3	16.0	14.8
25	17.8	16.6	15.4	14.2
24	17.1	16.0	14.8	13.7
23	16.4	15.3	14.2	13.1
22	15.7	14.7	13.6	12.6
21	15.0	14.0	13.0	12.0
20	14.3	13.4	12.4	11.5
19	13.6	12.7	11.8	10.9
18	12.9	12.1	11.2	10.4
17	12.2	11.4	10.6	9.8
16	11.5	10.8	10.0	9.3
15	10.8	10.1	9.4	8.7
14	10.1	9.5	8.8	8.2
13	9.4	8.8	8.2	7.6
12	8.7	8.2	7.6	7.1
11	8.0	7.5	7.0	6.5
10	7.3	6.9	6.4	6.0
9	6.6	6.2	5.8	5.4
8	5.9	5.6	5.2	4.9
7	5.2	4.9	4.6	4.3
6	4.5	4.3	4.0	3.8
5	3.8	3.6	3.4	3.3
4	3.1	3.0	2.8	2.7
3	2.4	2.3	2.2	2.1
2	1.7	1.7	1.6	1.6

GDT 7

**TABLE 3M—MOISTURE CORRECTION OF MINUS NO. 10 FOR % PLUS No. 10
(FOR + 10 ABSORPTION OF 2%)
% Plus No. 10 Material by Weight in Total Sample**

-10 Moisture	5	10	15	20	25
40	38.1	36.2	34.3	32.4	30.5
39	37.2	35.3	33.5	31.6	29.8
38	36.2	34.4	32.6	30.8	29.0
37	35.3	33.5	31.8	30.0	28.3
36	34.3	32.6	30.9	29.2	27.5
35	33.4	31.7	30.1	28.4	26.8
34	32.4	30.8	29.2	27.6	26.0
33	31.5	29.9	28.4	26.8	25.3
32	30.5	29.0	27.5	26.0	24.5
31	29.6	28.1	26.7	25.2	23.8
30	28.6	27.2	25.8	24.4	23.0
29	27.7	26.3	25.0	23.6	22.3
28	26.7	25.4	24.1	22.8	21.5
27	25.8	24.5	23.3	22.0	20.8
26	24.8	23.6	22.4	21.2	20.0
25	23.9	22.7	21.6	20.4	19.3
24	22.9	21.8	20.7	19.6	18.5
23	22.0	20.9	19.9	18.8	17.8
22	21.0	20.0	19.0	18.0	17.0
21	20.1	19.1	18.2	17.2	16.3
20	19.1	18.2	17.3	16.4	15.5
19	18.2	17.3	16.5	15.6	14.8
18	17.2	16.4	15.6	14.8	14.0
17	16.3	15.5	14.8	14.0	13.3
16	15.3	14.6	13.9	13.2	12.5
15	14.4	13.7	13.1	12.4	11.8
14	13.4	12.8	12.2	11.6	11.0
13	12.5	11.9	11.4	10.8	10.3
12	11.5	11.0	10.5	10.0	9.5
11	10.6	10.1	9.7	9.2	8.8
10	9.6	9.2	8.8	8.5	8.0
9	8.7	8.3	8.0	7.6	7.3
8	7.7	7.4	7.1	6.8	6.5
7	6.8	6.5	6.3	6.0	5.8
6	5.8	5.6	5.4	5.2	5.0
5	4.9	4.7	4.6	4.4	4.3
4	3.9	3.8	3.7	3.6	3.5
3	3.0	2.9	2.9	2.8	2.8
2	2.0	2.0	2.0	2.0	2.0

GDT 7

**TABLE 4M—MOISTURE CORRECTION OF MINUS NO. 10 FOR % PLUS No. 10 (FOR
+ 10 ABSORPTION OF 2%)
% Plus No. 10 Material by Weight in Total Sample**

-10 Moisture	30	35	40	45
40	28.6	26.7	24.8	22.9
39	27.9	26.1	24.2	22.4
38	27.2	25.4	23.6	21.8
37	26.5	24.8	23.0	21.3
36	25.8	24.1	22.4	20.7
35	25.1	23.5	21.8	20.2
34	24.4	22.8	21.2	19.6
33	23.7	22.2	20.6	19.1
32	23.0	21.5	20.0	18.5
31	22.3	20.9	19.4	18.0
30	21.6	20.2	18.8	17.4
29	20.9	19.6	18.2	16.9
28	20.2	18.9	17.6	16.3
27	19.5	18.3	17.0	15.8
26	18.8	17.6	16.4	15.2
25	18.1	17.0	15.8	14.7
24	17.4	16.3	15.2	14.1
23	16.7	15.7	14.6	13.6
22	16.0	15.0	14.0	13.0
21	15.3	14.4	13.4	12.5
20	14.6	13.7	12.8	11.9
19	13.9	13.1	12.2	11.4
18	13.2	12.4	11.6	10.8
17	12.5	11.8	11.0	10.3
16	11.8	11.1	10.4	9.7
15	11.1	10.5	9.8	9.2
14	10.4	9.8	9.2	8.6
13	9.7	9.2	8.6	8.1
12	9.0	8.5	8.0	7.5
11	8.3	7.9	7.4	7.0
10	7.6	7.2	6.8	6.4
9	6.9	6.6	6.2	5.9
8	6.2	5.9	5.6	5.3
7	5.5	5.3	5.0	4.8
6	4.8	4.6	4.4	4.2
5	4.1	4.0	3.8	3.7
4	3.4	3.3	3.2	3.1
3	2.7	2.7	2.6	2.6

2	2.0	2.0	2.0	2.0
---	-----	-----	-----	-----

GDT 7

TABLE 5M—MOISTURE CORRECTION OF MINUS NO. 10 FOR % PLUS No. 10
(FOR + 10 ABSORPTION OF 3%)
% Plus No. 10 Material by Weight in Total Sample

-10 Moisture	5	10	15	20	25
40	38.2	36.3	34.5	32.6	30.8
39	37.2	35.4	33.6	31.8	30.0
38	36.3	34.5	32.8	31.0	29.3
37	35.3	33.6	31.9	30.2	28.5
36	34.4	32.7	31.1	29.4	27.8
35	33.4	31.8	30.2	28.6	27.0
34	32.5	30.9	29.4	27.8	26.3
33	31.5	30.0	28.5	27.0	25.5
32	30.6	29.1	27.7	26.2	24.8
31	29.6	28.2	26.8	25.4	24.0
30	28.7	27.3	26.0	24.6	23.3
29	27.7	26.4	25.1	23.8	22.5
28	26.8	25.5	24.3	23.0	21.8
27	25.8	24.6	23.4	22.2	21.0
26	24.9	23.7	22.6	21.4	20.3
25	23.9	22.8	21.7	20.6	19.5
24	23.0	21.9	20.9	19.8	18.8
23	22.0	21.0	20.0	19.0	18.0
22	21.1	20.1	19.2	18.2	17.3
21	20.1	19.2	18.3	17.4	16.5
20	19.2	18.3	17.5	16.6	15.8
19	18.2	17.4	16.6	15.8	15.0
18	17.3	16.5	15.8	15.0	14.3
17	16.3	15.6	14.9	14.2	13.5
16	15.4	14.7	14.1	13.4	12.8
15	14.4	13.8	13.2	12.6	12.0
14	13.5	12.9	12.4	11.8	11.3
13	12.5	12.0	11.5	11.0	10.5
12	11.6	11.1	10.7	10.2	9.8
11	10.6	10.2	9.8	9.4	9.0
10	9.7	9.3	9.0	8.6	8.3
9	8.7	8.4	8.1	7.8	7.5
8	7.8	7.5	7.3	7.0	6.8
7	6.8	6.6	6.4	6.2	6.0
6	5.9	5.7	5.6	5.4	5.3
5	4.9	4.8	4.7	4.6	4.5
4	4.0	3.9	3.9	3.8	3.8

3	3.0	3.0	3.0	3.0	3.0
2	2.1	2.1	2.2	2.2	2.3

GDT 7

TABLE 6M—MOISTURE CORRECTION OF MINUS NO. 10 FOR % PLUS No. 10 (FOR + 10 ABSORPTION OF 3%)
% Plus No. 10 Material by Weight in Total Sample

-10 Moisture	30	35	40	45
40	28.9	27.1	25.2	23.4
39	28.2	26.4	24.6	22.8
38	27.5	25.8	24.0	22.3
37	26.8	25.1	23.4	21.7
36	26.1	24.5	22.8	21.2
35	25.4	23.8	22.2	20.6
34	24.7	23.2	21.6	21.1
33	24.0	22.5	21.0	19.5
32	23.3	21.9	20.4	19.0
31	22.6	21.2	19.8	16.4
30	21.9	20.6	19.2	17.9
29	21.2	19.9	18.6	17.3
28	20.5	19.3	18.0	16.8
27	19.8	18.6	17.4	16.2
26	19.1	18.0	16.8	15.7
25	18.4	17.3	16.2	15.1
24	17.7	16.7	15.6	14.6
23	17.0	16.0	15.0	14.0
22	16.3	15.4	14.4	13.5
21	15.6	14.7	13.8	12.9
20	14.9	14.1	13.2	12.4
19	14.2	13.4	12.6	11.8
18	13.5	12.8	12.0	11.3
17	12.8	12.1	11.4	10.7
16	12.1	11.5	10.8	10.2
15	11.4	10.8	10.2	9.6
14	10.7	10.2	9.6	9.1
13	10.0	9.5	9.0	8.5
12	9.3	8.9	8.4	8.0
11	8.6	8.2	7.8	7.4
10	7.9	7.6	7.2	6.9
9	7.2	6.9	6.6	6.3
8	6.5	6.3	6.0	5.8
7	5.8	5.6	5.4	5.2
6	5.1	5.0	4.8	4.7
5	4.4	4.3	4.2	4.1
4	3.7	3.7	3.6	3.6

3	3.0	3.0	3.0	3.0
2	2.3	2.4	2.4	2.5

GDT 7

TABLE 7M—MOISTURE CORRECTION OF MINUS NO. 10 FOR % PLUS No. 10
 (FOR + 10 ABSORPTION OF 4%)
 % Plus No. 10 Material by Weight in Total Sample

-10 Moisture	5	10	15	20	25
40	38.2	36.4	34.6	32.8	31.0
39	37.3	35.5	33.8	32.0	30.3
38	36.3	34.6	32.9	31.2	29.5
37	35.4	33.7	32.1	30.4	28.8
36	34.4	32.8	31.2	29.6	28.0
35	33.5	31.9	30.4	28.8	27.3
34	32.5	31.0	30.5	28.0	26.5
33	31.6	31.1	28.7	27.2	25.8
32	30.6	29.2	27.8	26.4	25.0
31	29.7	28.3	27.0	25.6	24.3
30	28.7	27.4	26.1	24.8	23.5
29	27.8	26.5	25.3	24.0	22.8
28	26.8	25.6	24.4	23.2	22.0
27	25.9	24.7	23.6	22.4	21.3
26	24.9	23.8	22.7	21.6	20.5
25	24.0	22.9	21.9	20.8	19.8
24	23.0	22.0	21.0	20.0	19.0
23	22.1	21.1	20.2	19.2	18.3
22	21.1	20.2	19.3	18.4	17.5
21	20.2	19.3	18.5	17.6	16.8
20	19.2	18.4	17.6	16.8	16.0
19	18.3	17.5	16.8	16.0	15.3
18	17.3	16.6	15.9	15.2	14.5
17	16.4	15.7	15.1	14.4	13.8
16	15.4	14.8	14.2	13.6	13.0
15	14.5	13.9	13.4	12.8	12.3
14	13.5	13.0	12.5	12.0	11.5
13	12.6	12.1	11.7	11.2	10.8
12	11.6	11.2	10.8	10.4	10.0
11	10.7	10.3	10.0	9.6	9.3
10	9.7	9.4	9.1	8.8	8.5
9	8.8	8.5	8.3	8.0	7.8
8	7.8	7.6	7.4	7.2	7.0
7	6.9	6.7	6.6	6.4	6.3
6	5.9	5.8	5.7	5.6	5.5
5	5.0	4.9	4.9	4.8	4.8
4	4.0	4.0	4.0	4.0	4.0

3	3.1	3.1	3.2	3.2	3.3
2	2.1	2.2	2.3	2.4	2.5

GDT 7

**TABLE 8M—MOISTURE CORRECTION OF MINUS NO. 10 FOR % PLUS No. 10 (FOR
+ 10 ABSORPTION OF 4%)
% Plus No. 10 Material by Weight in Total Sample**

-10 Moisture	30	35	40	45
40	29.2	27.4	25.6	23.8
39	28.5	26.8	25.0	23.3
38	27.8	26.1	24.4	22.7
37	27.1	25.5	23.8	22.2
36	26.4	24.8	23.2	21.6
35	25.7	25.4	22.6	21.1
34	25.0	23.5	22.0	20.5
33	24.3	22.9	21.4	20.0
32	23.6	22.2	20.8	19.4
31	22.9	21.6	20.2	18.9
30	22.2	20.9	20.6	18.3
29	21.5	20.3	19.0	17.8
28	20.8	19.6	18.4	17.2
27	20.1	19.0	17.8	16.7
26	19.4	18.3	17.2	16.1
25	18.7	17.7	16.6	15.6
24	18.0	17.0	16.0	15.0
23	17.3	16.4	15.4	14.5
22	16.0	15.7	14.8	13.9
21	15.9	15.1	14.2	13.4
20	15.2	14.4	13.6	12.8
19	14.5	13.8	13.0	12.3
18	13.8	13.1	12.4	11.7
17	13.1	12.5	11.8	11.2
16	12.4	11.8	11.2	10.6
15	11.7	11.2	10.6	10.1
14	11.0	10.5	10.0	9.5
13	10.3	9.9	9.4	9.0
12	9.6	9.2	8.8	8.4
11	8.9	8.6	8.2	7.9
10	8.2	7.9	7.6	7.3
9	7.5	7.3	7.0	6.8
8	6.8	6.6	6.4	6.2
7	6.1	6.0	5.8	5.7
6	5.4	5.3	5.2	5.1

5	4.7	4.7	4.6	4.6
4	4.0	4.0	4.0	4.0
3	3.3	3.4	3.4	3.5
2	2.6	2.7	2.8	2.9

GDT 7

TABLE 9M—MOISTURE CORRECTION OF MINUS NO. 10 FOR % PLUS No.10
(FOR + 10 ABSORPTION OF 5%)
% Plus No. 10 Material by Weight in Total Sample

-10 Moisture	5	10	15	20	25
40	38.3	36.5	34.8	33.0	31.3
39	37.3	35.6	33.9	32.2	30.5
38	36.4	34.7	33.1	31.4	29.8
37	35.4	33.8	32.2	30.6	29.0
36	34.5	32.9	31.4	29.8	28.3
35	33.5	32.0	30.5	29.0	27.5
34	32.6	31.1	29.7	28.2	26.8
33	31.6	30.2	28.8	27.4	26.0
32	30.7	29.3	28.0	26.6	25.3
31	29.7	28.4	27.1	25.8	24.5
30	28.8	27.5	26.3	25.0	23.8
29	27.8	26.6	25.4	24.2	23.0
28	26.9	25.7	24.6	23.4	22.3
27	25.9	24.8	23.7	22.6	21.5
26	25.0	23.9	22.9	21.8	20.8
25	24.0	23.0	22.0	21.0	20.0
24	23.1	22.1	21.2	20.2	19.3
23	22.1	21.2	20.3	19.4	18.5
22	21.2	20.3	19.5	18.6	17.8
21	20.2	19.4	18.6	17.8	17.0
20	19.3	18.5	17.8	17.0	16.3
19	18.3	17.6	16.9	16.2	15.5
18	17.4	16.7	16.1	15.4	14.8
17	16.4	15.8	15.2	14.6	14.0
16	15.5	14.9	14.4	13.8	13.3
15	14.5	14.0	13.5	13.0	12.5
14	13.6	13.1	12.7	12.2	11.8
13	12.6	12.2	11.8	11.4	11.0
12	11.7	11.3	11.0	10.6	10.3
11	10.7	10.4	10.1	9.8	9.5
10	9.8	9.5	9.3	9.0	8.8
9	8.8	8.6	8.4	8.2	8.0
8	7.9	7.7	7.6	7.4	7.3
7	6.9	6.8	6.7	6.6	6.5
6	6.0	5.9	5.9	5.8	5.8
5	5.0	5.0	5.0	5.0	5.0

4	4.1	4.1	4.2	4.2	4.3
3	3.1	3.2	3.3	3.4	3.5
2	2.2	2.3	2.5	2.6	2.8

GDT 7

**TABLE 10M—MOISTURE CORRECTION OF MINUS NO. 10 FOR % PLUS No. 10 (FOR + 10 ABSORPTION OF 5%)
% Plus No. 10 Material by Weight in Total Sample**

-10 Moisture	30	35	40	45
40	29.5	27.8	26.0	24.3
39	28.8	27.1	25.4	23.7
38	28.1	26.5	24.8	23.2
37	27.4	25.8	24.2	22.6
36	26.7	25.2	23.6	22.1
35	26.0	24.5	23.0	21.5
34	25.3	23.9	22.4	21.0
33	24.6	23.2	21.8	20.4
32	23.9	22.6	21.2	19.9
31	23.2	21.9	20.6	19.3
30	22.5	21.3	20.0	18.8
29	21.8	20.6	19.4	18.2
28	21.1	20.0	18.8	17.7
27	20.4	19.3	18.2	17.1
26	19.7	18.7	17.6	16.6
25	19.0	18.0	17.0	16.0
24	18.3	17.4	16.4	15.5
23	17.6	16.7	15.8	14.9
22	16.9	16.1	15.2	14.4
21	16.2	15.4	14.6	13.8
20	15.5	14.8	14.0	13.3
19	14.8	14.1	13.4	12.7
18	14.1	13.5	12.8	12.2
17	13.4	12.8	12.2	11.6
16	12.7	12.2	11.6	11.1
15	12.0	11.5	11.0	10.5
14	11.3	10.9	10.4	10.0
13	10.6	10.2	9.8	9.4
12	9.9	9.6	9.2	8.9
11	9.2	8.9	8.6	8.3
10	8.5	8.3	8.0	7.8
9	7.8	7.6	7.4	7.2
8	7.1	7.0	6.8	6.7
7	6.4	6.3	6.2	6.1
6	5.7	5.7	5.6	5.6
5	5.0	5.0	5.0	5.0
4	4.3	4.4	4.4	4.5
3	3.6	3.7	3.8	3.9
2	2.9	3.1	3.2	3.4

STUDY QUESTIONS

GDT 7

Determining Maximum Density of Soils

1. The metal mold used in this procedure shall have an approximate volume of _____?
2. A representative test sample, weighing about _____, should be obtained by using a _____, or by _____?
3. During sample preparation, a _____ sieve is used to split the sample into two portions?
4. What size sample is obtained from the thoroughly mixed portion of the materials passing the No. 10 (2.00 mm) sieve?
5. Each layer of soil material shall be compacted in the mold, using _____ blows from the rammer, dropped from _____ above the soil.
6. How many layers of material are compacted in the mold?
7. When compacting the test sample, the mold should rest on a _____ foundation weighing at least _____?
8. How often should the soil material be removed from the face of the rammer?
9. A _____ is used to level the sample to the top and bottom of the cylinder mold?
10. Calculate the wet weight of the compacted soil in pounds per cubic foot?

Weight of Mold	2002g
Weight of Mold + Sample	3800g
Mold Correction Factor	0.0665
Wet Weight, lbs./ft ³	

11. Samples for percent moisture are obtained by slicing the compacted soil through its center, and removing a _____ gram sample from the _____ of the compacted soil?
12. Calculate the percent moisture content?

Weight of Wet Soil	100g
Weight of Dry Soil	94g
Moisture %	

13. What amount of water is needed to increase the moisture content of a 3000g sample by 1 percent?

14. Moisture content of the soil should be increased by, (1 percent to 2 percent for _____ soils, 2 percent to 3 percent for _____ soils).
15. Repeat procedure until the soil becomes _____ and the _____ of the compacted soil substantially _____?
16. Calculate the dry weight of the compacted soil in pounds per cubic foot?

Wet Weight, lbs./ft ³	119.6
Moisture %	6.4
Dry Weight, lbs./ft ³	

17. Plot the moisture density data points, draw a smooth curve connecting the points?

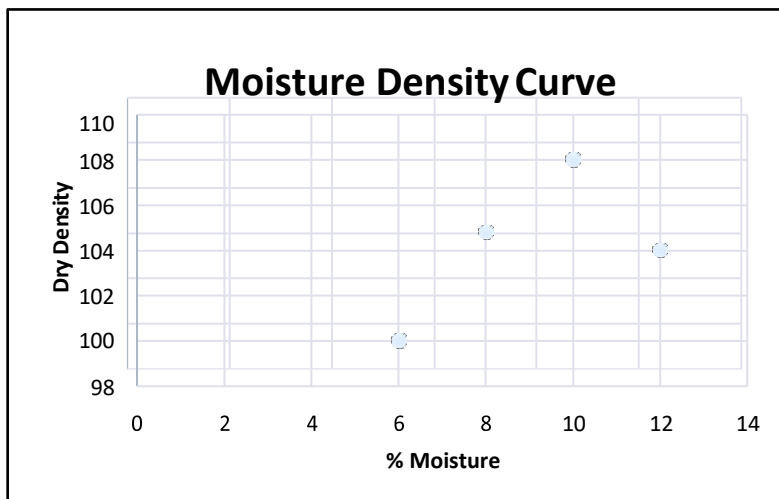

Dry Density	% Moisture
100.0	6.0
104.8	8.0
108.0	10.0
104.0	12.0

18. For _____ purposes, interpret the maximum dry density as the highest density obtained in the test series, and the optimum moisture as the moisture content at that respective density?
19. If the soil contains material retained on the No. 10 (2.00 mm) sieve and the _____ show density requirements on the total sample, you must correct the _____ to reflect the percentage of Plus No. 10 (2.00 mm) material?
20. It is not necessary to correct the density for percentage of Plus No. 10 (2.00 mm) material when determining maximum densities for compaction control?
 - a) True
 - b) False

21. Correct the maximum dry density and optimum moisture using the conversion factors in Tables 1D - 7D for maximum dry density and Tables 1M - 10M for optimum moisture?

- No. 10 Maximum Dry Density	108.0
- No. 10 Maximum Optimum Moisture	10.0
% Plus No. 10 Material	20.0
Corrected Maximum Dry Density	
Corrected Optimum Moisture	

Performance Checklist

GDT 7

Determining Maximum Density of Soils

1. Dry the soil sample thoroughly in air or in the drying apparatus at a temperature not exceeding 60°C [140°F].
2. Using a sampler, or by splitting or quartering, obtain a sample weighing approximately 10 lbs. (5 kg).
3. Record the sample mass and separate the sample into two portions using a No. 10 (2.00 mm) sieve.
4. Weigh and record the total mass of the sample.
5. Pulverize the sample in such a way as to avoid reducing the natural size of individual particles.
6. Separate the sample into two fractions using a 2.00-mm (No. 10) sieve.
7. Pulverize the material retained on the sieve until the aggregations of soil particles are broken into separate grains.
8. Re-sieve the ground soil on the 2.00-mm (No. 10) sieve.
9. Weigh and record the mass of material retained the 2.00-mm (No. 10) sieve.
10. Transfer the material passing the 2.00-mm (No. 10) sieve into a large pan or onto a suitable cloth and mix it thoroughly.
11. Using a sampler, or by splitting or quartering, obtain a sample with a mass of 6.6 lb. (3000 g).
12. Compact the test sample in the mold assembly in three equal layers.
 - Compact each layer with 25 blows from the rammer dropped from 1 ft (304.8 mm) above the soil.
 - Rest the mold on a uniform, rigid foundation, such as a concrete block weighing at least 200 lbs. (90 kg).
 - Uniformly distribute the blows over the surface of the compacted layer.
 - Remove the soil that adheres to the face of the rammer after every 25th blow.
13. After compacting, remove the extension and baseplate.
14. Carefully level the compacted soil to the top and bottom of the cylinder with the straightedge.
15. Weigh the cylinder and sample together.
16. Remove the compacted soil from the cylinder and slice it vertically through its center.
17. Take a 100 g sample from the center and weigh it immediately.

18. Dry the sample to a constant mass.
19. Thoroughly pulverize the remaining material from the compacted sample.
20. Add enough water to increase the moisture content of the soil in predetermined increments.
21. Repeat steps 12 through 18 until the soil becomes very wet and the wet weight of the compacted soil substantially decreases.
22. Repeat the procedure until the soil becomes very wet and the wet weight of the compacted soil substantially decreases.

SECTION 9

Georgia Department of Transportation Specifications, Section 810 – Roadway Materials



Section 810—Roadway Materials

810.1 General Description

This section includes the requirements for the materials used in roadway construction.

810.1.1 Related References

A. Standard Specifications

General Provisions 101 through 150.

B. Referenced Documents

GDT 4

GDT 6

GDT 7

GDT 67

810.2 Materials

810.2.1 Roadway Materials

A. Requirements

Do not use materials containing logs, stumps, sod, weeds, or other perishable matter.

1. Classes

The materials are divided into six major classes. Classes I, II, and III are further subdivided and identified by description and physical property requirements specified in the table below and in Table 1. Classes IV, V, and VI are identified by descriptive requirements.

Class I	
IA1 and IA2	Medium- to well-graded sand or clayey sand.
IA3	Fine-grained, silty, or clayey sand; usually less dense than IA1 or IA2. These soils have an excellent bearing capacity.
Class II	
IIB1, IIB2, and IIB3	Medium- to well-graded sandy clays, sandy silts, and clays with some mica. These soils generally have low volume change properties and good densities that serve well as subgrade material.
IIB4	Similar to IIB1, IIB2, and IIB3, but generally contain more mica and are more sensitive to moisture. The bearing value of these soils is less predictable. The soils may or may not be satisfactory for subgrade material. Analyze file data or run laboratory and/or field tests for Class IIB4 when considering it for a subgrade material.
Class III	

IIIC1, IIIC2, IIIC3 and IIIC4	<p>Medium- to fine-graded micaceous sandy silts, micaceous clayey silts, chert clays, and shaly clays. Undesirable characteristics are high volume change properties and/or low densities.</p> <p>The bearing values are unpredictable. The Department recommends testing these materials in a laboratory, where possible, before use. One exception is District 6, where chert clay soils are prevalent.</p> <p>Chert clay soils (IIIC4) with less than 55% passing the No. 10 (2 mm) sieve may be considered suitable for subgrade materials. These soils are found generally in the northwest corner of the state in Dade, Walker, Catoosa, Whitfield, Murray, Chattooga, Gordon, and Floyd counties.</p>
Class IV	Highly organic soils or peat, muck, and other unsatisfactory soils generally found in marshy or swampy areas.
Class V	Shaly materials that are not only finely laminated but have detrimental weathering properties and tend to disintegrate.
Class VI	Rock or boulders that cannot be readily incorporated into the embankment by layer construction, and that contain insufficient material to fill the interstices when they are placed.

Table 1: Physical Properties (Material Passing No. 10 (2.00 mm) Sieve)

Sub-Class	No. 60 (250 μ m) Sieve % Passing	No. 200 (75 μ m) Sieve % Passing	Clay, %	Volume Change, %	Maximum Dry Density lbs/ft ³ (kg/m ³)
Class I					
A1	15-65	0-25	0-12	0-10	115+ (1840+)
A2	15-85	0-35	0-16	0-12	100+ (1600+)
A3	15-100	0-25	0-12	0-18	98+ (1570+)
Class II					
B1		0-30	0-20	0-10	120+ (1920+)
B2		0-45	0-30	0-15	110+ (1760+)
B3		0-60	0-50	0-20	105+ (1680+)
B4		0-75		0-25	90+ (1440+)
Class III					
C1		0-75		0-30	90+ (1440+)
C2				0-35	80+ (1280+)
C3				0-60	80+ (1280+)
C4*					80- (1280-)
*Chert clay soils in District 6 having less than 55% passing the No. 10 (2.00 mm) sieve may be considered suitable for subgrade material.					

B. Fabrication

General Provisions 101 through 150.

C. Acceptance

Test as follows:

Test	Method
Soil gradation	GDT 4
Volume change	GDT 6
Maximum density	GDT 7 or GDT 67

D. Materials Warranty

General Provisions 101 through 150.

STUDY QUESTIONS

Georgia Department of Transportation Specifications, Section 810 – Roadway Materials

1. Roadway materials are divided into _____ major classes?
2. What classes are identified by descriptive requirements?
3. Materials containing logs, stumps, sod, weeds, or other perishable matter are acceptable?
 - a) True
 - b) False
4. Physical properties for class I, II, and III soils, are determined on the materials passing the _____ sieve.
5. Materials with physical properties meeting sub-class IIB3 requirements, would serve well as subgrade material?
 - a) True
 - b) False
6. Using the physical properties, determine the material sub-class?

% Passing No.40	20
% Passing No.60	32
% Passing No. 200	48
% Clay	50
% Volume Change	12
Maximum Dry Density lbs/ft ³	103
Classification	

SECTION 10

Georgia Department of Transportation Specifications, Section 814 – Soil Base Materials



Section 814—Soil Base Materials

814.1 General Description

This section includes the requirements for soil base materials, including topsoil or sand-clay, soil-cement, sand for bituminous stabilization, and chert.

814.1.1 Related References

A. Standard Specifications

Section 209— Subgrade Construction
Section 301— Soil-Cement Construction
Section 800—Coarse Aggregate
Section 810—Roadway Materials

Section 831—Admixtures

B. Referenced Documents

AASHTO T 89
AASHTO T 90
ASTM D 516
GDT 4
GDT 6
GDT 7
GDT 65
GDT 67
GDT 98

814.2 Materials

814.2.1 Topsoil or Sand-Clay

A. Requirements

1. Use topsoil or sand-clay that is a natural or artificial mixture of clay or soil binder with sand or other aggregate. Do not use a mixture that contains substances detrimental to the material.
Obtain the materials from sources approved by the Engineer.
Ensure that the aggregate retained on No. 10 (2 mm) sieve (coarse aggregate) is of hard, durable particles.
2. Sand and Binder
Use hard, sharp, durable, siliceous particles. Use binder made from quality clay.
3. Oversize
Remove particles with diameters greater than 2 in (50 mm) before depositing the topsoil or sand-clay on the road.
Remove particles with screens or grizzlies, or by hand if few oversized pieces exist. You may crush the oversized pieces

and use them.

4. Topsoil

Use a topsoil that is a natural, generally pebbly material occurring in shallow surface deposits on usually elevated areas.

5. Natural Sand-Clay

Use a natural sand-clay that is a mixture of natural material, largely sand and clay in proper proportions, occurring in deposits of considerable depth.

6. Artificial Sand-Clay

Use an artificial sand-clay that is largely a mixture of artificial sand and clay. You may make the mixture by combining clay or soil binder and sand or aggregate in the proper proportions.

7. Topsoil and Sand-Clay

Use topsoil and sand-clay with the following properties:

Sieve Size	Amount
Passing 2 in (50 mm)	100% by weight
Passing 1-1/2 in (37.5 mm)	80-100% by weight

Passing No. 40 (425 µm)	Liquid Limit (LL) of 25 or less Plasticity Index (PI) of 9 or less
-------------------------	---

8. Ensure that material passing the No. 10 (2 mm) sieve meets the following requirements:

Sieve Size	Percent Passing by Weight
Passing No. 10 (2 mm) sieve	100
Passing No. 60 (250 µm) sieve	15-85
Passing No. 200 (75 µm) sieve	9-35
Clay	9-25
Volume change, max. percent	12
Maximum density, lb/ft ³ (kg/m ³)	110+ (1760+)

B. Fabrication

General Provisions 101 through 150.

C. Acceptance

The Department or Producer will test as follows:

Test	Method
Soil gradation	GDT 4
Volume change	GDT 6
Maximum density	GDT 7 or GDT 67
Liquid Limit	AASHTO T 89
Plastic Limit and Plasticity Index	AASHTO T 90

D. Materials Warranty

General Provisions 101 through 150.

814.2.2 Soil-Cement Material

A. Requirements

- 1. Ensure that the material for soil-cement base will:
 - a. Meet the requirements of Subsection 810.2.01 for Classes IA1, IA2, IA3, or IIB1 with the following modifications:

Clay content	5 to 25%
Volume change	18% maximum
Liquid Limit	25% maximum
Plasticity Index	10% maximum
Maximum dry density	95 lb/ft ³ (1520 kg/m ³) minimum
Sulfates	4000 ppm maximum
pH	4.0 minimum

- b. Be friable and not contain large amounts of heavy or plastic clay lumps, organic material, roots, or other substances that would interfere with how the Portland cement sets, plant production, or the finished surface of the base and meet the requirements of Subsection 301.3.05.A.2, "Pulverization" or Subsection 301.3.05.B.1, "Soil".
 - c. Produce a laboratory unconfined compressive strength of at least 450 psi (3.1 MPa). To make the sample, mix in a minimum of 5% to a maximum of 9 percent Type I Portland cement, moist-cure for 7 days, and test with GDT 65.
 - 2. Analyze the soil-cement design and create a Job Mix Formula for each Project where soil-cement base or subbase is specified. Have the Job Mix Formula approved by the Engineer before starting base or subbase construction.
 - 3. You may use flyash or slag that meets the requirements of Subsection 831.2.03 as admixtures for poorly reacting soils when the blend of soil and flyash, or slag, meets the design requirements in this Subsection.
 - 4. Ensure that subgrade material used underneath the soil-cement base meets the sulfate and pH requirements of this subsection (See Subsection 209.3.05.A.7).

B. Fabrication

General Provisions 101 through 150.

C. Acceptance

Test as follows:

Test	Method
Soil gradation	GDT 4
Volume Change	GDT 6
Maximum density	GDT 7 or GDT 67
Soil-Cement Design	GDT 65
pH	GDT 98
Sulfates	ASTM D 516

Liquid Limit	AASHTO T 89
Plastic Limit and Plasticity Index	AASHTO T 90

D. Materials Warranty

General Provisions 101 through 150.

STUDYQUESTIONS

Georgia Department of Transportation Specifications, Section 814 – Soil Base Materials

1. Subgrade material used underneath soil-cement base shall be tested for sulfate and pH?
 - a) True
 - b) False
2. For materials used as sand-clay base, the materials passing the _____ sieve shall have a _____ of 9 or less?
3. Particles with diameters greater than _____ shall be removed before depositing topsoil or sand-clay on the road?
4. Laboratory specimens for a soil-cement mix design should be cured for _____ days and should produce an unconfined compressive strength of at least _____ psi (_____ MPa)?
5. Soils meeting classes IIB2 are suitable for use as soil-cement material?
 - a) True
 - b) False
6. Materials passing the No. 10 sieve, used in sand-clay base, shall have a maximum dry density of _____ lbs/ft³?
7. What test method is required to perform PH testing for materials used in soil-cement base construction?
 - a) GDT 98
 - b) GDT 6
 - c) T 96
 - d) None of the above

SECTION 11

**Georgia Department of
Transportation Appendix**

Appendix A

Answers to Study Questions

Section 1

AASHTO R 58, Standard Practice for Dry Preparation of Disturbed Soil and Soil-Aggregate Samples for Test

1. This method describes the **dry** preparation of soil and soil–aggregate samples?
2. A revolving drum, into which the soil sample and rubber-covered rollers are placed, is a suitable pulverizing device?
 - a) **True**
 - b) False
3. For the particle size analysis-T88, material passing a 2.00-mm (No. 10) sieve is required in amounts equal to approximately, 110 g for **sandy** soils and approximately 60 g for **silty or clayey** soils.
4. What is the minimum amount required, of material passing the 0.425-mm (No. 40) sieve, for performing physical testing?**300g**
5. Samples should be dried at a temperature not exceeding **60°C[140°F]**?
6. Representative test samples of the amount required to perform the desired tests shall be taken with a **sampler**, or by **splitting or quartering**.
7. Samples dried in an oven or other drying apparatus at a temperature not exceeding 60°C [140°F] are considered to be air dried?
 - a) **True**
 - b) False
8. List the two alternate methods used to separate fraction sizes of the portion of the dried sample selected for particle-sized analysis and physical tests? **Alternate Methods Using 2.00-mm (No. 10) Sieve, Alternate Method Using 4.75-mm and 2.00-mm (Nos. 4 and 10) Sieves**

9. Fractions retained on the 4.75-mm (No. 4) sieve and the 2.00-mm (No. 10) sieve are not included in the sieve analysis and should be discarded?
 - a) True
 - b) false
10. What is the required sample mass of material passing the 2.00-mm (No. 10) sieve, for specific gravity, when the volumetric flask is to be used? 25g
11. Physical tests are performed on materials passing the 0.425-mm (No. 40) sieve?

Section 2

AASHTO T 89

Standard Method of Test for Determining the Liquid Limit of Soils

1. The liquid limit of a soil is that water content at which the soil passes from a plastic to a liquid state.
2. An unglazed, porcelain dish about 115 mm in diameter is preferred for mixing the sample.
3. The liquid limit device shall have a base made of resilient material.
4. List the two types of grooving tools used in this procedure. Curved grooving tool, flat grooving tool (alternate)
5. The flat grooving tool should be used interchangeably with the curved grooving tool?
 - a) true
 - b) false
6. Obtain a sample mass of about 100 g of material passing 0.425-mm sieve for method "A".
7. Cup or base wear is considered excessive when the point of contact exceeds 13 mm in diameter.
8. The height of drop of the cup should be adjust to 10.0 +/- 0.2 mm and checked each day prior to testing.
9. What is the initial amount of water to be added to the sample?
 - a) Method "A": 15 to 20 mL
 - b) Method "B": 8 to 10 mL
10. It is ok to add dry soil material if too much moisture has been added to the sample.
 - a) True
 - b) False

11. A **false liquid limit** value may be obtained by adding water too fast.
12. What is the maximum thickness allowed when spreading material into the testing cup? **10mm**
13. How many firm strokes of the grooving tool are allowed to divide the soil in the cup? **Up to six from front to back or back to front counting as one stroke**
14. The cup containing the sample shall be **lifted** and **dropped** by turning crank F at a rate of approximately **two** revolutions per second.
15. What steps are taken should the sample slide on the cups surface during test? **Add more water to the sample and remix, then place soil-water mixture in cup, a groove cut and test repeated**
16. The **cup** and **grooving tool** shall be washed and dried between test trials.
17. When performing procedure "A", obtain the first test sample in the range of **25** to **35** shocks.

18. Water content of the soil shall be calculated as follows:

a) True	b) False	$\frac{\text{mass of water}}{\text{Mass of oven dry soil}} \times 100$
---------	-------------	--
19. The moisture content corresponding to the intersection of the flow curve with the **25-shock** ordinate shall be taken as the **liquid limit** of the soil.
20. Sample shall be seasoned in the **humidifier** for **30 min** when performing referee testing.

Section 3

AASHTO T 90

Standard Method of Test for Determining the Plastic Limit and Plasticity Index of Soils

1. The **plastic limit** of a soil is the lowest **moisture content** at which the soil remains plastic.

2. The plasticity index is the numerical difference between the **liquid limit** and the **plastic limit** of the soil.
3. What method shall be used as the referee method? **Hand Rolling Method**
4. Wax paper would be an acceptable rolling surface?
 - a) True
 - b) False**
5. The container used for moisture content shall have a **close-fitting lid** to prevent the loss of moisture from the samples before initial mass determination.
6. If only the plastic limit is determined, what is the initial sample mass, of material passing the 0.425-mm (No. 40) sieve, required for this procedure? **20g**
7. Tap water may be used for routine testing?
 - a) **True**
 - b) False
8. The soil mass should be rolled into a **3-mm thread** at a rate of **80 to 90 strokes** per minute.
9. What is the time limit for rolling the soil mass into a thread? **Shouldn't take longer than 2min**
10. When using the alternate procedure, you should not allow the soil thread to contact the **side rails** of the plastic limit device?
11. It is acceptable for crumbling to occur when the diameter is **greater** than 3 mm, provided the solid has been previously rolled into a thread **3 mm** in diameter?
12. Attempts should be made to produce failure at exactly 3-mm by reducing hand pressure?
 - a) True
 - b) False**
13. **Heavy clay** soils require much pressure to deform the thread as they approach the plastic limit?
14. What procedure should be used to determine the moisture content? **T265**
15. The plastic limit of the soil is the moisture content expressed as a percentage of the **oven-dry mass**?
16. Report the plastic limit to the nearest **whole number**?
17. How is the plasticity index of a soil calculated? **Plasticity index = plastic limit – liquid limit**

Section 4

AASHTO T 265

Standard Method of Test for Laboratory Determination of Moisture Content of Soils

1. **Moisture** or **water content** of a soil is the ratio, expressed as a percentage, of the mass of water in a given mass of soil to the mass of the solid particles?
2. Containers shall have close-fitting lids to prevent **loss of moisture** from samples before initial weighing and to prevent **absorption of moisture** from the atmosphere following drying and before final weighing.
3. If not indicated in the method of test, what is the minimum sample mass for a soil with a maximum particle size of 12.5-mm (1/2 in.)? **300g**
4. Test samples shall be dried in a drying oven maintained at a temperature of **110 ± 5°C (230 ± 9°F)**?
5. Samples should be dried overnight (minimum of **15** hr.) or dry until the mass loss of the sample after 1 h of additional drying is less than **0.1** percent (constant mass)?
 - a) True
 - b) False
7. Oven-drying at 110 ± 5°C (230 ± 9°F) does not result in reliable moisture content values for soil containing **gypsum** or other minerals having loosely bound water from **hydration** or for soil containing significant amounts of **organic material**.
8. When is it acceptable to use a container without a tight-fitting lid? **provided the moist sample is weighed immediately after being taken, and provided the dried sample is weighed immediately after being removed from the oven or after cooling in a desiccator**
9. When calculating moisture content, $W_1 =$ **mass of container and moist soil, g**?
10. What is the single operator precision, acceptable range of two results, when testing a coarse aggregate-blend?
0.1

Section 5

AASHTO T180 (Method D)

Moisture- Density Relation of Soils Using 10 lb. Rammer and an 18" Drop and using Material Passing the # 3/4 Sieve

1. The mold in this procedure will have an approximate diameter of 6 inches and height of 4.584inches.
2. The metal rammer will have a diameter of 2 in and a weight of 10lbs (4.536kg). The rammer will be dropped at a height of 18 inches from the surface the soil.
3. What size sample is taken and dried in a drying apparatus at a temperature not to exceed what temperature?
25lb, 140°F(60°C)
4. Any material retained on the 3/4 sieve shall be considered oversized.
5. A representative sample of approximately 25lbs(11.34kg) of -3/4 material is needed to perform the test.
6. What should the initial moisture content of the sample be mixed to? 4 to 8 % below optimum

7. Each moisture content shall be compacted with 56 uniform blows in five equal layers?

8. After the mold has been compacted, the collar is removed, and the compacted material tined where?

- a) at the top of the mold
- b) bottom of the mold
- c) Both the top and the bottom

9. Calculate the wet weight of the compacted soil in pounds per cubic foot?

Weight of Mold	6595.3 g
Weight of Mold + Sample	11614.5 g
Mold Correction Factor	0.02942
Wet Weight, lbs./ft ³	147.6
Weight of Mold	6595.3 g
Weight of Mold +Sample	11733.8 g
Mold Volume	0.07498
Wet Weight, lbs./ft ³	151.1

10. Samples for determining moisture content are obtained by slicing the compacted soil vertically through its center and removing the cut face or from the center of the pile if the molded material falls apart.

11. Calculate the percent moisture content?

Weight of Wet Soil	1098.8 g
Weight of Dry Soil	928.6 g
Moisture %	18.3

12. Moisture samples will be dried in an oven capable of maintain what temperature? 230°F(110°C)T

13. Moisture will be increased at a rate of approximately 1% to 2% and material compacted until a decrease or no change in the wet weight is reported.

14. Plot the moisture density data points, draw a smooth curve connecting the points?

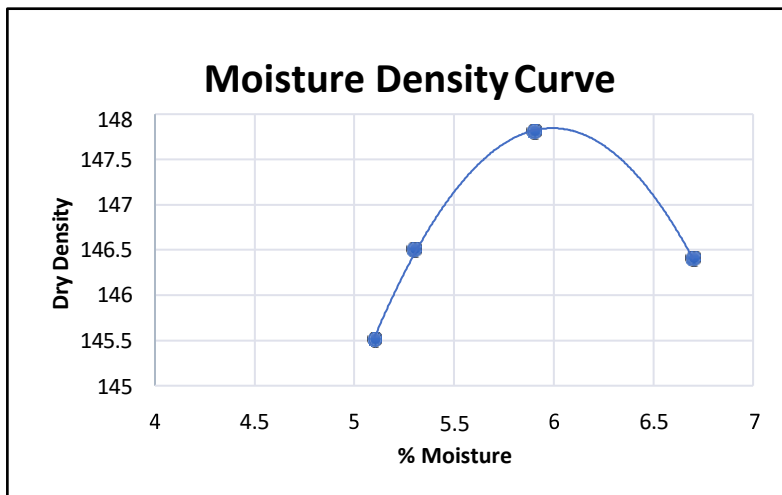

Dry Density	% Moisture
145.5	5.1
146.5	5.3
147.8	5.9
146.4	6.7

15. The theoretical maximum dry density and optimum moisture will be measured from?

- a) Highest plotted density
- b) the plotted density after decline
- c) Highest moisture content
- d) the peak of the curve

Section 6

GDT 4

Determining Gradation of Soils

1. Glass bottles used for this procedure must be clear and free of chips?
2. A Sodium Hexametaphosphate solution mixture of 5 gal (19 L) potable water, and 10 oz (285 g) of Sodium

Hexametaphosphate is needed for this procedure?

3. A reversible siphon assembly is used for changing the water in the bottle?
4. Initial drying of the sample shall be performed at a temperature not exceeding 140 °F(60°C)?
5. If coarse material is present, what test procedure is used to grade the aggregates? AASHTOT27
6. Samples for density, and volume change are taken from materials that pass the No. 10 (2.00 mm) sieve?

Procedure

7. How many samples of material passing the No. 10 (2.00 mm) sieve are weighed out for grading and what are their individual masses? Two samples, 50g each
8. The sample used for determining the original dry weight, for calculating the grading of the minus No. 10 (2.00 mm) material, should be dried overnight 20 hours ± 1/2 hour to a constant weight?
9. How much sodium hexametaphosphate solution should be in the test bottle when initially adding the test sample? About 2 in.
10. The sample in the test bottle should be vigorously stirred with a glass rod to reduce the cohesive forces of the clay.
11. How long should the test sample and hexametaphosphate solution be allowed to stand before adding water? At least 10 min
12. After filling the test bottle with water, the test bottle should be allowed to stand undisturbed for 8 to 10 mins before the water is siphoned off?
13. Fluid should be siphoned off until it is about 3/4 in (18 mm) above the soil?
14. The refilling and siphoning process should continue until the fluid above the sample becomes clear enough to read a watch on the opposite side of the bottle.
15. Washed samples should be dried to a constant mass at a temperature of 230 ° ± 9 °F (110 ° ± 5 °C)?

16. When calculating the percent passing a sieve smaller than the No. 10 (2.00 mm), A = the weight of the 50.0 g sample after it was dried to a constant weight?

a) True

b) False

17. Calculate percent passing and adjusted for total percent passing:

Total Sample Weight = 28,000g			
Gradation of Plus No. 10 (2.00 mm)			
Sieve	Accumulative Weight Retained	Percent of Total Sample	
		Retained	Passing
1-1/2 (37.5 mm)	0	0	100.0
3/4 (19.0 mm)	5,000	17.9	82.1
10 (2.0 mm)	17,000	60.7	39.3

Gradation of Minus No. 10 (2.00 mm)				
Weight of 50 g sample after drying = 49.5g				Adjusted for Total Sample Percent Passing
Sieve	Accumulative Weight Retained	Retained	Passing	
40 (425 µm)	16.3	32.9	67.1	26.4
60 (250 µm)	26.5	53.5	46.5	18.3
200 (75 µm)	39.8	80.4	19.6	7.7
Total	42.6	86.1		
Clay (effluent) =			13.9	5.5

Section 7

GDT 6

Determining the Volume Change of Soils

1. It is ok to use the same mold for both the shrinkage test and the swell test?
 - a) True
 - b) False
2. The metal rammer used for this test shall have a 2 in diameter flat circular face and weigh 5.5 lbs.
3. When using a mechanical rammer, check the tolerances semi-annually using the procedures in AASHTOT-99?
4. What is the minimum depth of the water vat required for this test? 1½ in (38 mm) deep
5. A flat perforated metal plate with five 3/8 in (10 mm) diameter holes located symmetrically under each specimen shall be used to dry and cool shrinkage specimens.
6. The three measuring devices shall be readable to and sensitive to one-thousandth 0.001 in.?
7. The following device is used to measure shrinkage thickness?

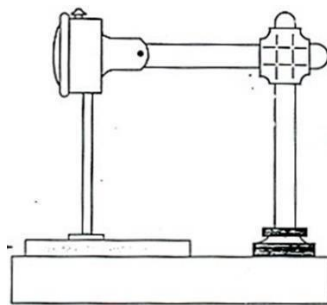

8. A sample mass of 2.2 +0.0022 lbs. (1000 + 1.0 g) should be taken from the materials passing the 2.00-mm (No. 10) sieve as obtained according to GDT4?
9. Optimum moisture content used for this procedure should be determined by GDT 7 or GDT 67?.
10. The test sample should be allowed to stand, in a plastic bag, at optimum moisture content, for a minimum of 1 hour?
11. How many freefalls of the hammer are required to compact the swell test specimen? 25 freefalls

12. Swell test base plates should be preadjusted, so the micrometer reads zero on the 0.875 in. (22.22 mm) constant of the calibration tool, with the mold removed.
13. Swell specimens should remain in the water vat undisturbed for 20 ½ hours before removing the paper and recording the final thickness measurement?

14. Calculate the percentswell?

Original Dial Reading	.143''
Final Dial Reading	.180''
Swell %	3.6 %

15. The original thickness measurement, when measuring shrinkage, shall be taken before the specimen is extruded from the mold?

- a) True
- b) False

16. Shrinkage specimens shall be allowed to air dry for about 1 hour after compacting and measuring all specimens to be tested?

17. When determining the final diameter dial reading, the circular end of the specimen should face the same direction as the dial to ensure proper centering of the specimen?

18. Calculate the percentshrinkage?

B =	.758
FT =	.750
FD =	.740
Shrinkage %	1.3

19. Calculate the total volume change using the results from questions No. 14 and No. 18?

Total Volume Change = 4.9%

Section 8

GDT 7

Determining Maximum Density of Soils

1. The metal mold used in this procedure shall have an approximate volume of $1/30 \text{ ft}^3$ ($0.000943, \pm 0.000008 \text{ m}^3$)?
2. A representative test sample, weighing about **10 lbs. (5 kg)**, should be obtained by using a **sampler**, or by **splitting and quartering**?
3. During sample preparation, a **No. 10 (2.00 mm)** sieve is used to split the sample into two portions?
4. What size sample is obtained from the thoroughly mixed portion of the materials passing the No. 10 (2.00 mm) sieve? **6.6 lb. (3000 g)sample**
5. Each layer of soil material shall be compacted in the mold, using **25** blows from the rammer, dropped from **1 ft (304.8 mm)** above the soil.
6. How many layers of material are compacted in the mold? **3**
7. When compacting the test sample, the mold should rest on a **rigid** foundation weighing at least **200 lbs. (90 kg)**?
8. How often should the soil material be removed from the face of the rammer? **after every 25th blow**
9. A **straightedge** is used to level the sample to the top and bottom of the cylinder mold?
10. Calculate the wet weight of the compacted soil in pounds per cubic foot?

Weight of Mold	2002g
Weight of Mold + Sample	3800g
Mold CorrectionFactor	0.0665
Wet Weight, lbs./ft ³	119.6

11. Samples for percent moisture are obtained by slicing the compacted soil through its center, and removing a **100** gram sample from the **center** of the compacted soil?
12. Calculate the percent moisture content?

Weight of Wet Soil	100g
Weight of Dry Soil	94g
Moisture %	6.4

13. What amount of water needed to increase the moisture content of a 3000g sample by 1 percent? **1 oz (30 ml)**

14. Moisture content of the soil should be increased by, (1 percent to 2 percent for **sandy** soils, 2 percent to 3 percent for **clay** soils).
15. Repeat procedure until the soil becomes **very wet** and the **wet weight** of the compacted soil substantially **decreases**?
16. Calculate the dry weight of the compacted soil in pounds per cubic foot?

Wet Weight, lbs./ft ³	119.6
Moisture %	6.4
Dry Weight, lbs./ft ³	112.4

17. Plot the moisture density data points, draw a smooth curve connecting the points?

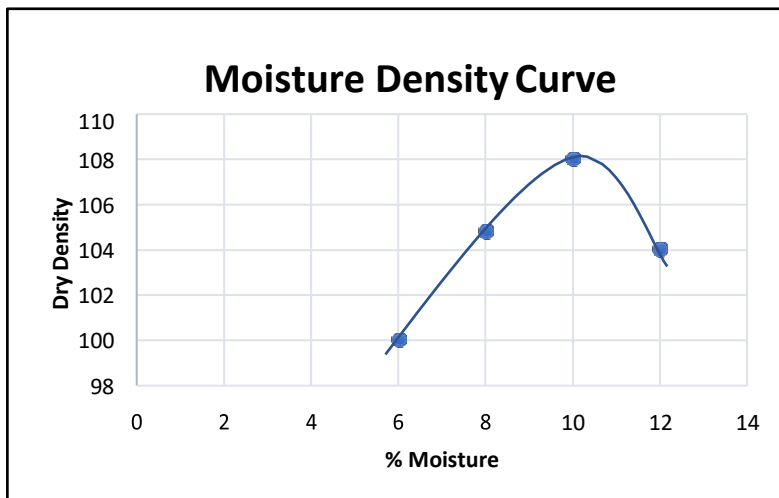

Dry Density	% Moisture
100.0	6.0
104.8	8.0
108.0	10.0
104.0	12.0

18. For **classification** purposes, interpret the maximum dry density as the highest density obtained in the test series, and the optimum moisture as the moisture content at that respective density?
19. If the soil contains material retained on the No. 10 (2.00 mm) sieve and the **specifications** show density requirements on the total sample, you must correct the **maximum dry density** to reflect the percentage of Plus No. 10 (2.00 mm) material?
20. It is not necessary to correct the density for percentage of Plus No. 10 (2.00 mm) material when determining maximum densities for compaction control?
 - a) True
 - b) False**

21. Correct the maximum dry density and optimum moisture using the conversion factors in Tables 1D - 7D for maximum dry density and Tables 1M - 10M for optimum moisture?

- No. 10 Maximum Dry Density	108.0
- No. 10 Maximum Optimum Moisture	10.0
% Plus No. 10 Material	20.0
Corrected Maximum Dry Density	113.9
Corrected Optimum Moisture	8.5

Section 9

Georgia Department of Transportation Specifications, Section 810 – Roadway Materials

1. Roadway materials are divided into **six** major classes?
2. What classes are identified by descriptive requirements? **Classes IV, V, and VI**
3. Materials containing logs, stumps, sod, weeds, or other perishable matter are acceptable?
 - a) True
 - b) False**
4. Physical properties for class I, II, and III soils, are determined on the materials passing the **No. 10 (2.00 mm)** sieve.

5. Materials with physical properties meeting sub-class IIB3 requirements, would serve well as subgrade material?

a) True

b) False

6. Using the physical properties, determine the material sub-class?

% Passing No.40	20
% Passing No.60	32
% Passing No.200	48
% Clay	50
% Volume Change	12
Maximum Dry Density lbs/ft ³	103
Classification	IIB4

Section 10

Georgia Department of Transportation Specifications, Section 814 – Soil Base Materials

1. Subgrade material used underneath soil-cement base shall be tested for sulfate and pH?
 - a) True
 - b) False
2. For materials used as sand-clay base, the materials passing the No. 40 sieve shall have a Plasticity Index (PI) of 9 or less?
3. Particles with diameters greater than 2 in (50 mm) shall be removed before depositing topsoil or sand-clay on the road?
4. Laboratory specimens for a soil-cement mix design should be cured for 7 days and should produce an unconfined compressive strength of at least 450 psi (3.1 MPa)?
5. Soils meeting classes IIB2 are suitable for use as soil-cement material?
 - a) True
 - b) False
6. Materials passing the No. 10 sieve, used in sand-clay base, shall have a maximum dry density of 110+ lbs/ft³?
7. What test method is required to perform PH testing for materials used in soil-cement base construction?
 - a) GDT 98
 - b) GDT 6
 - c) T 96
 - d) None of the above